

# QUICK START GUIDE

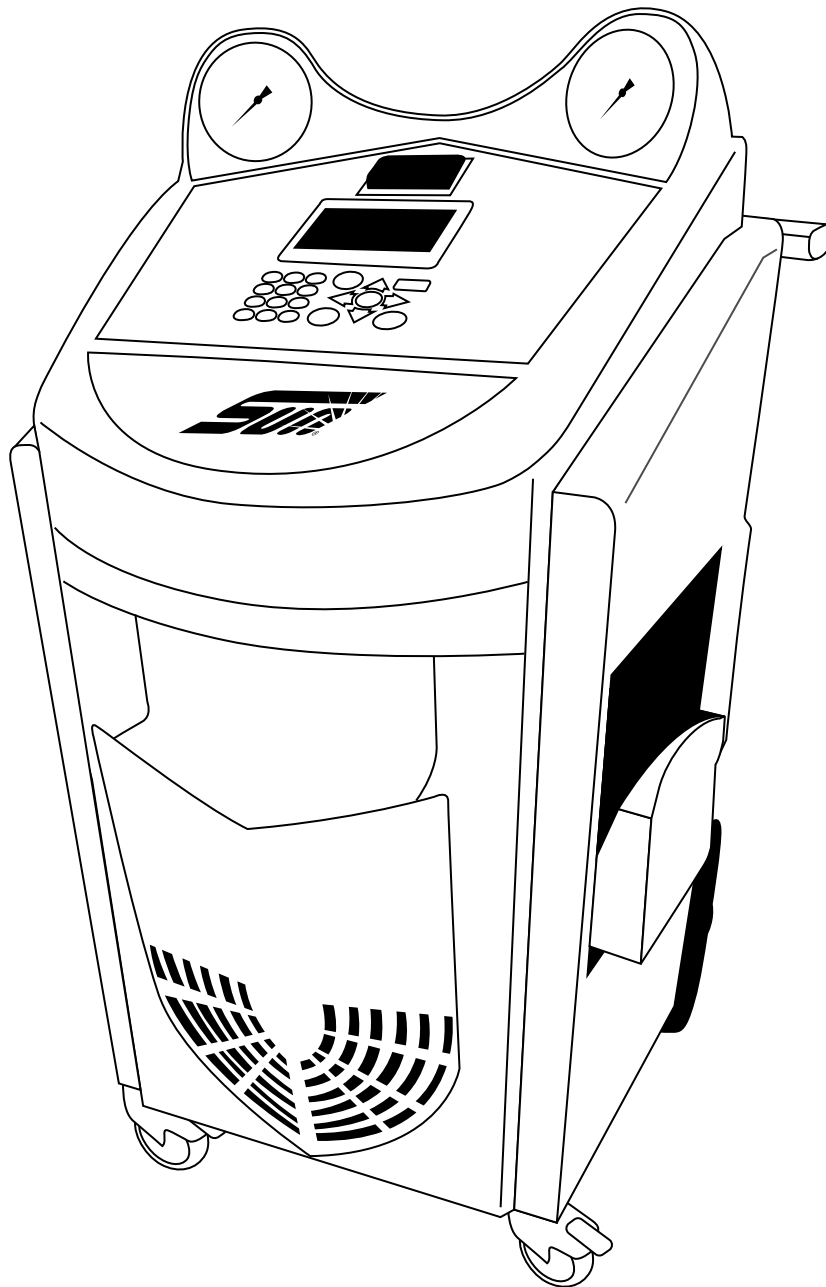

CHECK OUT OUR VIDEO TUTORIAL AND VISIT:  
[DIAGNOSTICS.SNAPON.CO.UK/TRAINING](http://DIAGNOSTICS.SNAPON.CO.UK/TRAINING)

EAZ0042N00A

## BLIZZARD AIR CONDITIONING UNIT

QUALITY AND SERVICE YOU EXPECT AT A PRICE YOU WOULDN'T

## 1 PACKAGING

Check the condition of your delivery, remove the 4 security locks and lift the box off the pallet.

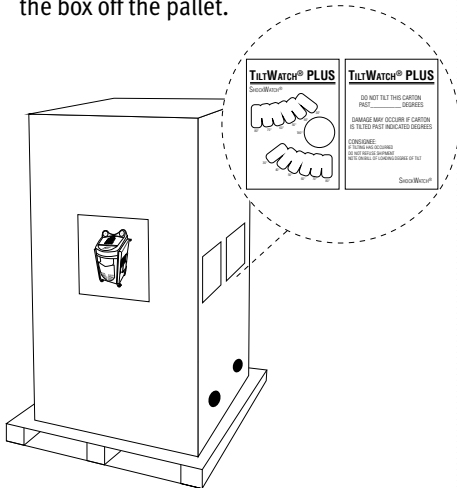

## 2

Remove protective cover, Quick Start Guide and accessory pack.

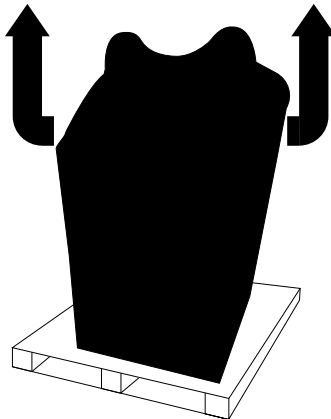

## 3

Release the brake and roll off the pallet.

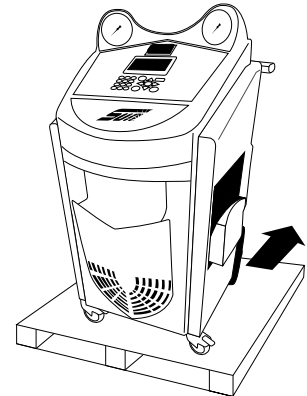

## 4

Connect the power cable, switch on and wait for the unit to boot up.

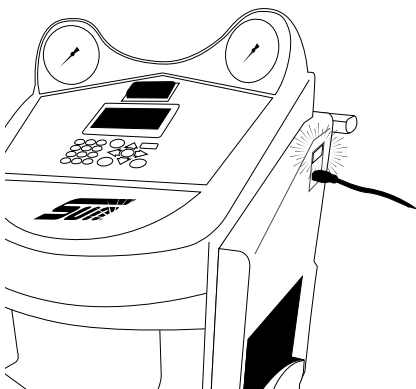

## 5 PRODUCT ACTIVATION

Follow the instructions on the screen, make a note of the activation code provided.



## 6

Open your web browser and enter: [www.ac-activation.com](http://www.ac-activation.com) into the address bar. When prompted enter your activation code and fill out the mandatory fields as required. On completion you will be provided with your unique unlock code.

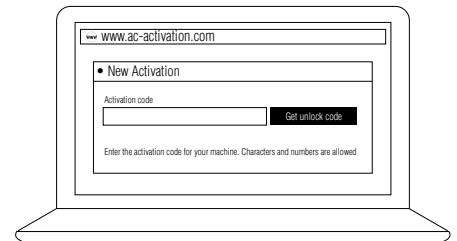

*Note: The website URL will change to: <http://www.ac-service24.com/attivazione>*

## 7

Enter the unlock code on the unit.



## 8a SCALE UNLOCKING

Follow the instruction on your unit display. Once you have completed the required task press 'OK' to continue.



## 8b

Unlock security nut fully to release the scale.

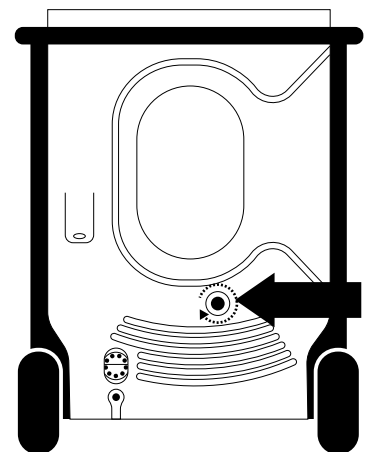

## 9a VACUUM PUMP

Follow the instruction on your unit display. Once you have completed the required task press 'OK' to continue.

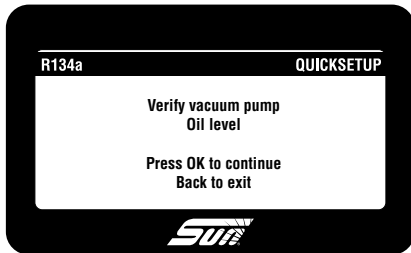

## 9b

Check the oil level. The oil should be at the halfway mark.

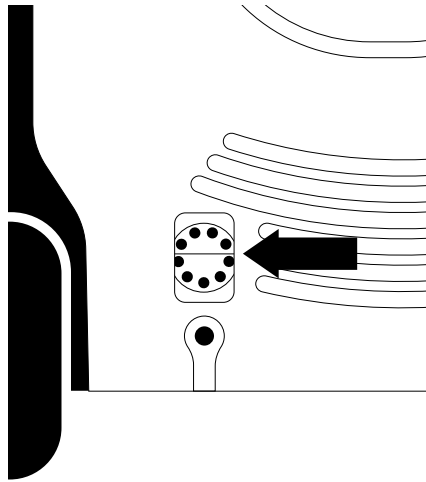

## 10 INSERTING TRACER DYE AND OIL

Follow the instruction on your unit display. When prompted, confirm the oil container, select the HR bottle, then press 'OK' to continue.

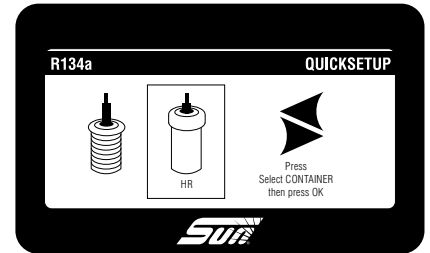

## 11a

**WARNING:** Using oil tracer DYE which is not approved by the manufacturer could result in malfunction and warranty decline

Follow the instruction on your unit display. Once you have completed the required task press 'OK' to continue.

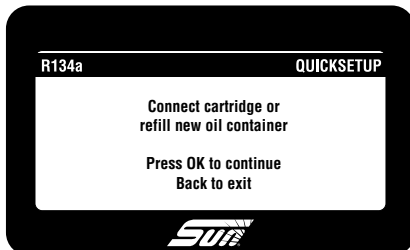

## 11b

Release and open the the blue bottle, fill it with oil and return it back to the unit.

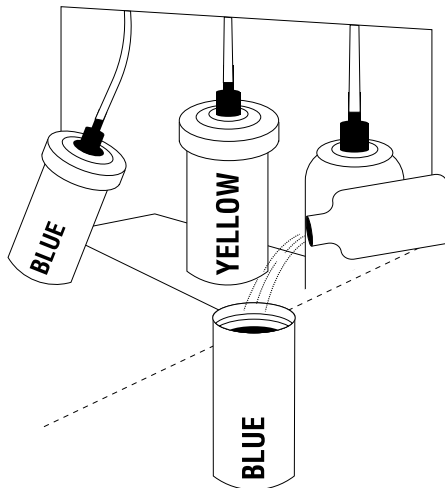

## 12a

Follow the instruction on your unit display. Once you have completed the required task press 'OK' to continue.

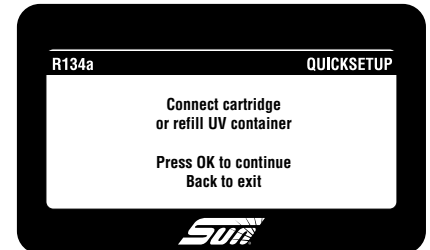

## 12b

Release and open the the yellow bottle, fill it with UV tracer dye and return it back to the unit.

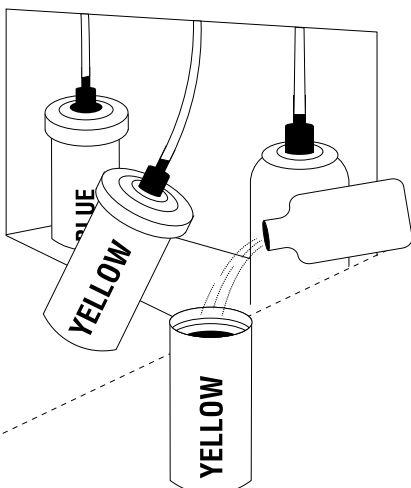

## 13 VACUUM TEST

Press 'OK' to proceed with the vacuum procedure.



Wait for the vacuum test to finish, this may take a few minutes.

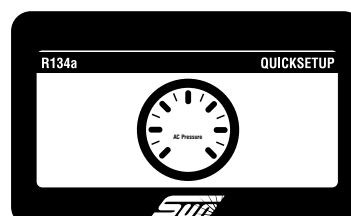

## 14 GAS BOTTLE FILLING

**CAUTION:**  
Use suitable  
protective  
equipment (PPE)  
while handling gas

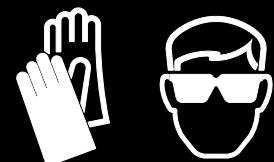

15

Connect the appropriate bottle adaptor to the external gas bottle. Once complete press 'OK' on the unit display.

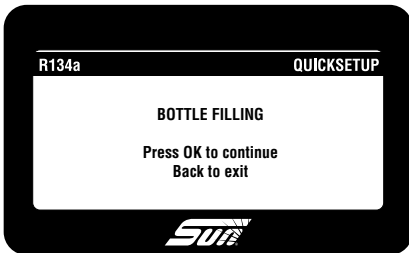

16

The display will then prompt you to connect and open the LP or HP coupler.

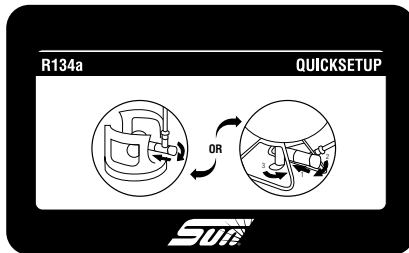

17

Once connected, open the valve on the external bottle and position bottle for liquid filling.

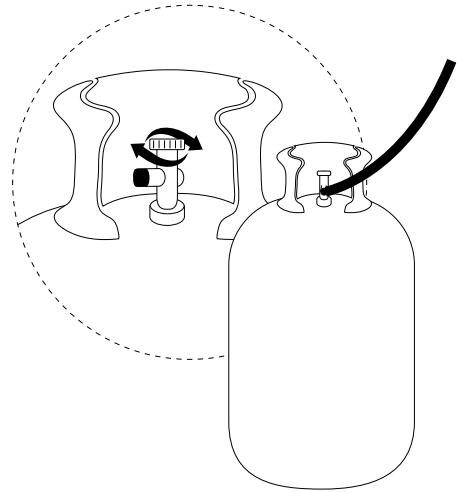

18

Insert the gas quantity between min and max levels and press 'OK', wait for the system to start the gas filling.

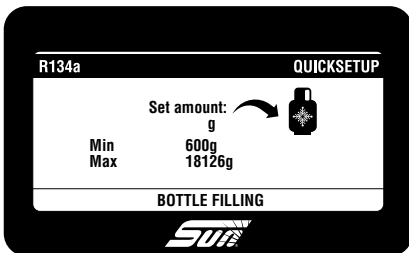

19

The unit will prompt you to close the HP/ LP coupler. Once complete click 'OK' to continue

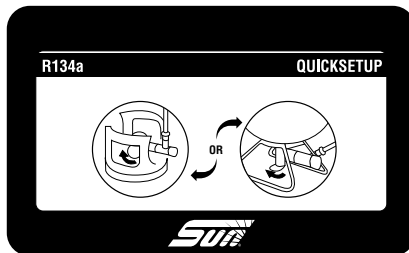

20

Wait for the bottle filling cycle to complete.

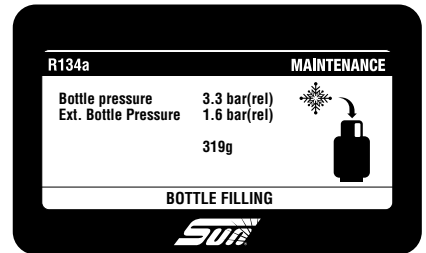

21

Disconnect the LP/HP coupler.

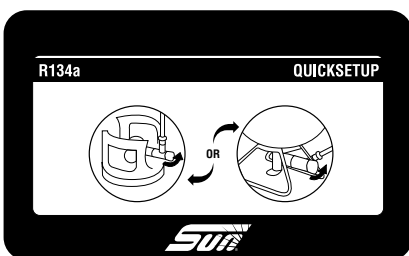

22

Return to the main menu.

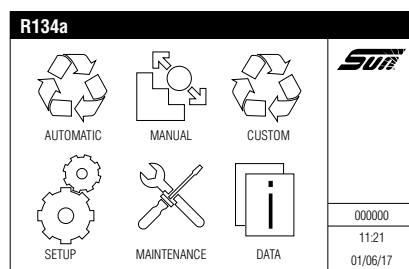

**YOUR UNIT IS  
NOW READY  
FOR USE**

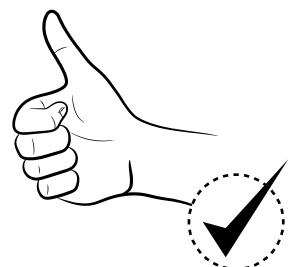

## OPTIONAL KOOLKLEAN SET-UP

Have you purchased a Blizzard Pro or Blizzard HFO?

Follow our instructions to set up your Koolklean unit.

1

Unpack the Koolklean contents

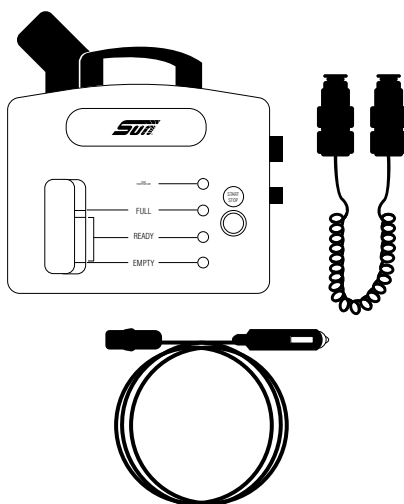

2

You will require Koolklean fluid. You can purchase appropriate fluid at: [www.snaponconsumables.co.uk](http://www.snaponconsumables.co.uk)

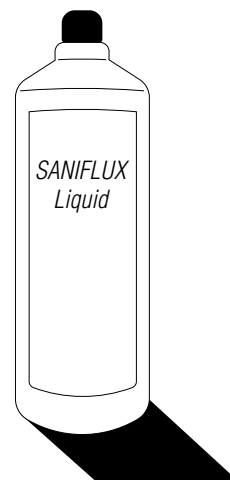

3

Remove the head attachment and fill the Koolklean unit with fluid up to top of the 'READY' mark. Once filled place the head attachment back onto the Koolklean unit.

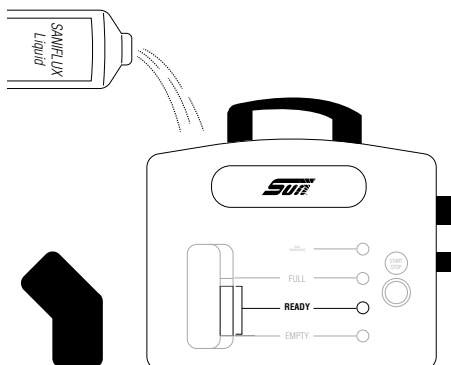

4

Plug the power cable to the unit.

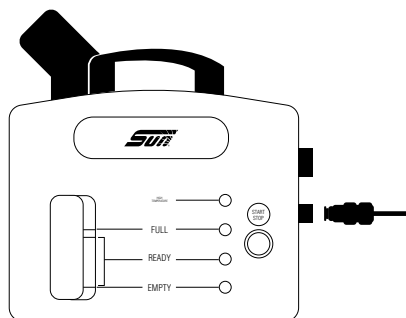

5

Plug the data cable to the unit.

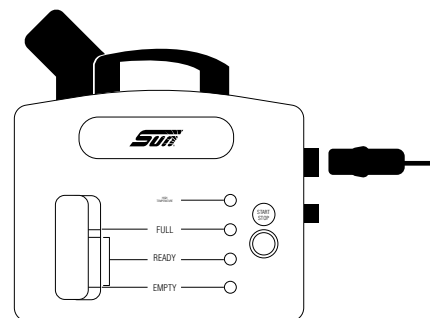

6

Dock the Koolklean unit onto the AC unit.

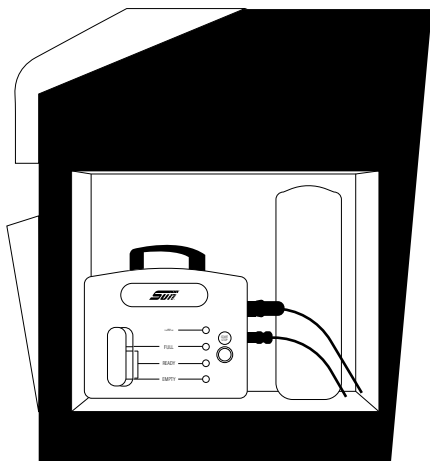

7

Attach the data cable to the AC unit.

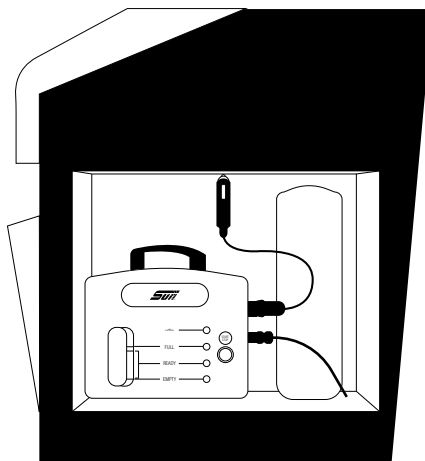

**YOUR  
KOOLKLEAN  
SYSTEM IS NOW  
READY FOR USE**

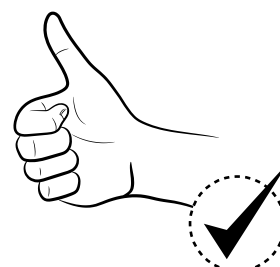



◀ Scan this code to view our training and support tools

Denney Road, King's Lynn, Norfolk PE30 4HG

tel: +44 (0) 1553 692422

email: [ukservice@snapon.com](mailto:ukservice@snapon.com) - <http://diagnostics.snapon.co.uk>

***Snap-on***<sup>®</sup>