

MODIS™ Edge

User Manual



Legal Information

Trademarks

Snap-on is a trademark, registered in the United States and other countries, of Snap-on Incorporated. This publication contains many Snap-on Incorporated trademarks, including but not limited to Snap-on, and ShopStream. All other marks are trademarks or registered trademarks of their respective holders.

Copyright Information

© 2018 Snap-on Incorporated. All rights reserved.

Disclaimer of Warranties and Limitation of Liabilities

All pictures and illustrations shown are for reference purposes only. All information, specifications and illustrations in this manual are based on the latest information available at the time of printing and are subject to change without notice. While the authors have taken due care in the preparation of this manual, nothing contained herein:

- Modifies or alters in any way the standard terms and conditions of the purchase, lease, or rental agreement under the terms of which the equipment to which this manual relates was acquired.
- Increases in any way the liability to the customer or to third parties.

Snap-on[®] reserves the right to make changes at any time without notice.

IMPORTANT:

Before operating or maintaining this unit, please read this manual carefully paying extra attention to the safety warnings and precautions.

Software License Information

Use of Software is governed by the terms and conditions of the End User License Agreement. The diagnostic tool should not be initially operated until the End User License Agreement is read. Use of the device acknowledges your acceptance of the End User License Agreement. The Snap-on Incorporated Software End User License Agreement may be provided with the diagnostic tool, and is available at: <https://eula.snapon.com/diagnostics>.

Patent Information

For a listing of Snap-on products that are protected by patents in the United States and elsewhere, visit: <https://patents.snapon.com>

User Manual Information

This manual includes information and images applicable with diagnostic software version 18.4 and later. Some information within this manual may not be applicable with other diagnostic software versions.

The information in this manual is periodically revised to ensure the latest information is included. The current version of this manual and other technical documentation is available online from Snap-on Diagnostics.

Product Support Information

Phone / E-mail - Technical Assistance

+44 (0) 845 601 4736 / diagnosticsUKproductsupport@snapon.com

Website Links:

Snap-on Diagnostics and Information

- <http://diagnostics.snapon.co.uk>

Manuals / Technical Documentation - This manual is periodically revised to ensure the latest information is included. Download the latest version of this manual and other related technical documentation at:

- <https://www.snapon.com/diagnostics/uk/User-Manuals.htm>

For technical assistance in all other markets, contact your selling agent.

Product Training Videos

Diagnostic tool specific training videos are available on our website. Follow along and learn the basics of diagnostic tool operation with our free training videos.

Videos are product specific and are available at:

<http://diagnostics.snapon.co.uk> - Click on the "Training and Support" tab, select "Diagnostic Tools", then select the applicable diagnostic tool, and then select "See Quick Tips".



NOTE:

Sample titles are listed below. Not all titles may be available for all diagnostic tools, and are subject to change.

Snap-on® Training Solutions® - Training Videos (examples)	
Introduction and Navigation	Global OBD-II
Scanner Codes	Digital Multimeter
Scanner Data in PID View	Graphing Multimeter & Lab Scope
Scanner Data in Graphing View	Guided Component Tests
Fast-Track® Troubleshooter	Vehicle Specs & Resets
Functional Tests	SureTrack® & Wi-Fi

Diagnostic Quick Tips - Video Series

Snap-on Diagnostic Quick Tips videos are available at no charge on our website and on our YouTube channel. These videos are developed from real repair case studies to help professional technicians use diagnostic tools to solve specific vehicle problems (e.g. performing a Ford Relative Injector Flow Test).

Additional videos are also available showing specific diagnostic tool features (e.g. ShopStream Connect - Software Updates).



Figure 1-1

Videos are available at:

<http://diagnostics.snapon.co.uk> - Click on "Diagnostic Tools", then select the applicable diagnostic tool, then select "See Quick Tips"

<https://www.youtube.com/user/snaponscanner/videos> - Use the search function to find a title, or enter "Diagnostic Quick Tips" in the search field to see a list of all applicable titles.



NOTE:

URL links (above) and titles listed (below) are subject to change and may not be available in all markets.

A sample list of titles are listed below, other titles may be available.

Some videos may not be applicable for use with all diagnostic tools.

Snap-on® Training Solutions® - Diagnostic Quick Tips Videos (examples)	
Air/Fuel Ratio Sensor Test	Fuel Injector Voltage and Current Tests (Scope)
Alternator Ripple Test (Scope)	Fuel Pump Current Ramp Test (Scope)
BMW® Rain Sensor Calibration	Harley-Davidson® ABS Brake Bleed
CAN Bus Diagnostics (Scope)	Harley-Davidson® Functional Tests
Chevrolet® Volt Coolant Pump Bleed	Harley-Davidson® Key Fob Programming

Snap-on® Training Solutions® - Diagnostic Quick Tips Videos (examples)	
Chrysler HVAC Test	Hyundai Blind Spot Detection System Calibration
Chrysler VVT System Cleaning	Hyundai Occupant Detection System Reset
Chrysler Wheel & Tire Calibrations	Ignition Coil Current and Voltage Comparison
COP Ignition Test	Ignition Coil Current Ramp Test
Dual Screen Diagnostics: Scanner vs. Scope	Ignition Coil Primary Voltage Test
Electronic Throttle Control System Diagnostics	Ignition System Diagnostics Using the SIA2000 (Scope)
FIAT® 500 Proxi Alignment	MINI Battery Relearn
FIAT® 500 Throttle Body Relearn	Multi Channel Cam / Crank Correlation
Flex Ray Bus Diagnostics	OBD-II Mode 10 Permanent Codes
Ford Battery Monitor System	Oil Specs & Service Light Resets
Ford Coil Current RFI Test (Scope)	PID Trigger Functions (Scanner)
Ford Flash Reprogramming	Piezo Injectors Signature Test
Ford Misfire Monitor Neutral Profile Correction (Scanner)	Relative Compression Test (Scope)
Ford PATS Key Programming	ShopStream Connect - Data Manipulation
Ford Relative Compression Test	ShopStream Connect - Software Updates
Ford Relative Injector Flow Test	Speed Up Your Diagnostics (Scanner)
Ford TPMS Reprogramming	The Power of Troubleshooter Tips (Scanner)
Ford® 6.7L Transmission Solenoid Characterization	Top Level Menus: Built In Scope Training
Ford® Diesel Injector Coding	Toyota EVAP Test
VW / Audi Flexible Service Reset (Scanner)	Toyota Multiple Freeze Frame (Scanner)
	Toyota Transmission Compensation Coding

Contents

Safety Information	ix
Chapter 1: Using This Manual	1
Conventions	1
Bold Text	1
Symbols	1
Terminology	1
Notes and Important Messages	2
Hyperlinks	2
Procedures	2
Chapter 2: Introduction	3
Control Buttons	3
Data and Power Connections	4
Battery Pack and Stand	5
Power Sources	6
Internal Battery Pack	6
AC Power Supply	6
Vehicle Power	6
Technical Specifications	7
Chapter 3: Basic Operation and Navigation	8
Turning On/Off and Emergency Shutdown	8
Turning On	8
Turning Off	8
Emergency Shutdown	9
Basic Navigation	9
Home Screen Layout	9
Title Bar	10
Home Screen Icons	11
Common Toolbar Control Icons	12
Scroll Bar	13
Screen Messages	13
System Messages	13
Communication Messages	14
Data Cable Connection	14
Chapter 4: Scanner	16
Screen Layout and Toolbar Icons	16
Screen Layout	16
Scanner Control Icons	17
Scanner Demonstration Program	17
Scanner Operation	18
Connecting the Data Cable	18
Vehicle Identification	18

System Selection	20
System Main Menu Options	21
Exiting Scanner	34
SureTrack	34
SureTrack Operation	34
Chapter 5: Vehicle Code Scan / (ALTUS™).....	40
Using Code Scan.....	41
Total Number of Systems (modules) Analyzed.....	43
List of All the Systems Analyzed with DTCs Totals.....	43
SureTrack® Common Replaced Parts Graph.....	44
Global OBDII DTCs.....	45
Readiness Monitor Test Status	45
Vehicle System Report (ALTUS™)	46
Printing the Vehicle System Report	46
Chapter 6: OBD-II/EOBD	47
Basic Operations	47
Screen Layout and Toolbar Controls	47
Connecting the Data Cable	47
Saving and Reviewing Data Files	47
OBD-II/EOBD Menu	47
OBD Health Check.....	48
OBD Direct.....	50
Chapter 7: TSBs.....	57
Operation.....	57
Chapter 8: Guided Component Tests	61
Training and Classes.....	61
Power User Tests	62
How To Guide	62
Features and Benefits	62
Index	63
Screen Layout and Icons.....	63
Screen Layout.....	63
Guided Component Tests Control Icons	64
Operation.....	65
Component Information	66
Tests	68
Saving and Reviewing Data Files	70
Chapter 9: Previous Vehicles and Data.....	71
Previous Vehicles and Data Menu	71
Vehicle History	71
View Saved Data	72
Viewing Codes and Code Scan Results	73
Delete Saved Data.....	75
Chapter 10: Scope Multimeter.....	76
Overview.....	76

Digital Multimeter (DMM)	76
Graphing Multimeter (GMM)	77
Lab Scope	78
Tests and Capabilities (Quick Reference)	79
Test Leads and Accessories	81
Channel 1 Lead	81
Channel 2 Lead	81
Alligator Clips and Probes	82
Secondary Ignition Coil Adapter Lead and Clip-on Adapter (optional)	82
Low Amp Current Probe (optional)	83
Pressure Transducers and Adapters (optional)	83
General Information	84
Scope Multimeter Screen Layout and Features	84
Measurement Out of Range (Alert)	86
Operation and Controls	87
Test Lead / Probe Connection	87
Test Lead / Probe Calibration	88
Control Panel and Settings	89
Secondary Ignition Testing	104
Optional Settings	106
Display (Grid on/off)	106
Divisions	107
Saving and Reviewing Scope / Multimeter Data Files	110
Data Buffer	110
Saving Files	111
Stopping and Reviewing Data Files	112
Saving Screens	113
Using the Zoom Function	114
General Reference	117
Basic Setup Tips (unknown signal type)	117
Using Known Good Waveforms	118
Troubleshooting Signals	119
Units of Measurement / Conversions	120
Glossary of Common Terms	122
Chapter 11: Tools	125
Tools Menu	125
Connect-to-PC	126
Configure Shortcut Button	127
System Information	127
Settings	128
Chapter 12: Maintenance	136
Cleaning and Inspecting the Diagnostic Tool	136
Cleaning the Touch Screen	136
Battery Pack Service	136
Battery Pack Safety Guidelines	137
Replacing the Battery Pack	138
Disposing of the Battery Pack	139

Chapter 13: ALTUS (ALTUSDRIVE.com) - Cloud Sharing/Storage	140
Key Features	140
Important Notes	140
Registration - Getting Started	141
ALTUS - New User Registration	141
ALTUS Setup Information Screen.....	142
Using ALTUS	143
Quick Reference (print / download / share)	143
Logging in to ALTUS (registered user).....	143
Navigating ALTUS (Toolbars)	144
My Files.....	145
Search.....	149
Favorites	150
Profile.....	151
Chapter 14: Wi-Fi Connection / Troubleshooting	156
Checking if Wi-Fi is On/Off	156
Checking if Wi-Fi is Connected	157
Wi-Fi Icons (Setup).....	157
Turning Wi-Fi On and Connecting to a Network.....	157
Add Network Advanced (Connecting to a hidden network).....	159
Wi-Fi Testing	159
Wi-Fi Troubleshooting and Status Messages	161
Informative Messages	163
Chapter 15: ShopStream Connect	164
Using SSC (Connecting to your PC)	164
SSC Main Screen	165
Scanner DataViewer.....	166
Image Viewer.....	167
Printing the (Code Scan) Vehicle System Report.....	168
Customizing the (Code Scan) Vehicle System Report.....	169
Software Upgrades and Updates	172
End User License Agreement	173

Safety Information

READ ALL INSTRUCTIONS

For your own safety, the safety of others, and to prevent damage to the product and vehicles upon which it is used, it is important that all instructions and safety messages in this manual and the accompanying *Important Safety Instructions* manual be read and understood by all persons operating, or coming into contact with the product, before operating. We suggest you store a copy of each manual near the product in sight of the operator.

For your safety, read all instructions. Use your diagnostic tools only as described in the tool user's manual. Use only manufacturer recommended parts and accessories with your diagnostic tools.

This product is intended for use by properly trained and skilled professional automotive technicians. The safety messages presented throughout this manual and the accompanying *Important Safety Instructions* manual are reminders to the operator to exercise extreme care when using this product.

There are many variations in procedures, techniques, tools, and parts for servicing vehicles, as well as in the skill of the individual doing the work. Because of the vast number of test applications and variations in the products that can be tested with this instrument, we cannot possibly anticipate or provide advice or safety messages to cover every situation. It is the responsibility of the automotive technician to be knowledgeable of the system being tested. It is essential to use proper service methods and test procedures. It is important to perform tests in an appropriate and acceptable manner that does not endanger your safety, the safety of others in the work area, the equipment being used, or the vehicle being tested.

It is assumed that the operator has a thorough understanding of vehicle systems before using this product. Understanding of these system principles and operating theories is necessary for competent, safe and accurate use of this instrument.

Before using the equipment, always refer to and follow the safety messages and applicable test procedures provided by the manufacturer of the vehicle or equipment being tested. Use the product only as described in its user manual. Use only manufacturer recommended parts and accessories with your product.

Read, understand and follow all safety messages and instructions in this manual, the accompanying *Important Safety Instructions* manual, and on the test equipment.

Environmental Conditions:

- This product is intended for indoor use only
- This product is rated for Pollution Degree 2 (normal conditions)

Safety Signal Words

All safety messages contain a safety signal word that indicates the level of the hazard. An icon, when present, gives a graphical description of the hazard. Safety Signal words are:

DANGER

Indicates an imminently hazardous situation which, if not avoided, will result in death or serious injury to the operator or to bystanders.

WARNING

Indicates a potentially hazardous situation which, if not avoided, could result in death or serious injury to the operator or to bystanders.

CAUTION

Indicates a potentially hazardous situation which, if not avoided, may result in moderate or minor injury to the operator or to bystanders.

Safety Message Conventions

Safety messages are provided to help prevent personal injury and equipment damage. Safety messages communicate the hazard, hazard avoidance and possible consequences using three different type styles:

- Normal type states the hazard.
- **Bold type states how to avoid the hazard.**
- *Italic type states the possible consequences of not avoiding the hazard.*

An icon, when present, gives a graphical description of the potential hazard.

Safety Message Example

WARNING



Risk of unexpected vehicle movement.

- **Block drive wheels before performing a test with engine running.**

A moving vehicle can cause injury.

Important Safety Instructions

For a complete list of safety messages, refer to the accompanying *Important Safety Instructions manual*.

SAVE THESE INSTRUCTIONS

This manual contains tool usage instructions. Some of the illustrations shown in this manual may contain modules and optional equipment that are not included on your system. Contact your sales representative for availability of other modules and optional equipment.

1.1 Conventions

The following conventions are used.

1.1.1 Bold Text

Bold emphasis is used in procedures to highlight selectable items such as buttons and menu options.

Example:

- Press the **OK** button.

1.1.2 Symbols

Different types of arrows are used.

The “greater than” arrow (>) indicates an abbreviated set of selection instructions.

Example:

- Select **Tools > Connect-to-PC**.

The example statement abbreviates the following procedure:

1. Select **Tools** from the home screen.
2. Highlight **Connect-to-PC** on the Tools menu.
3. Select **Connect-to-PC**.

The solid arrows (◀, ▶, ▼, ▲) are navigational instructions referring to the four directions of the directional arrow keys.

Example:

- Press the down ▼ arrow.

1.1.3 Terminology

The term “select” means tapping an item on the touch screen, or highlighting a button or menu item and pressing the **Accept, OK, Yes, or other similar** button to confirm the selection.

Example:

- Select **Brightness**.

The above statement abbreviates the following procedure:

1. Navigate to and highlight the **Brightness** selection.
2. Press the **OK, or similar,** button.

1.1.4 Notes and Important Messages

The following messages are used.

Notes

A NOTE provides helpful information such as additional explanations, tips, and comments.

Example:



NOTE:

For additional information refer to...

Important

IMPORTANT indicates a situation which, if not avoided, may result in damage to the test equipment or vehicle.

Example:

IMPORTANT:

Do not disconnect the data cable while the Scanner is communicating with the ECM.

1.1.5 Hyperlinks

Hyperlinks, or hot links, that take you to other related articles, procedures, and illustrations are available in electronic documents. Blue colored text indicates a selectable hyperlink.

Example:

IMPORTANT:

Read all applicable safety information before using this tool!

1.1.6 Procedures

An arrow icon in the left-margin area indicates a procedure.

Example:



To change screen views:

1. Select the **Graph** icon.
The dropdown menu displays.
2. Select an option from the menu.
The screen layout changes to the format selected.

The MODIS™ Edge is a multi-function tool that combines a Diagnostic Scan Tool with a two-channel lab scope, graphing multimeter, and the exclusive Snap-on® Guided Component Tests database into a single hand-held unit.



This chapter introduces the basic features of the Diagnostic Tool, including the control buttons, data ports, battery pack, and power sources. Technical Specifications are provided at the end of this chapter.



2.1 Control Buttons

There are four “push type” control buttons and one “thumb pad rocker type” multi-directional button located on the right side of the Diagnostic Tool. All other Diagnostic Tool operations are controlled through the touch screen.

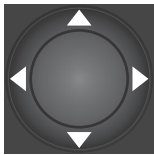

Figure 2-1 Front view

Item	Button	Description	
1		N/X or Cancel - Push type button	<ul style="list-style-type: none"> To exit a menu or program. To close an open list and return to the previous menu or screen. To answer “No” when a yes/no choice is given.
2		Y/✓ or Accept - Push type button	<ul style="list-style-type: none"> To confirm a selection from a menu or program. To select an item that was highlighted using the direction arrows. To advance to the next screen in a series. To answer “Yes” when a yes or no choice is given.

Item	Button	Description	
3		Directional - Thumb pad rocker type buttons	Buttons move the cursor or highlight in their respective direction: <ul style="list-style-type: none"> • Up (▲) • Down (▼) • Left (◀) • Right (▶)
4		S (Shortcut) - Push type button	Programmable function button that can provide a shortcut for performing a variety of routine tasks. Refer to Configure Shortcut Button , on page 127 for additional information.
5		Power (On/Off) - Push type button	Turns the Diagnostic Tool on and off. Also, press and hold for 5 seconds for emergency shutdown.

2.2 Data and Power Connections

Connectors and jacks for the scope multimeter, data communication cables and the AC power supply are located on the top of the Diagnostic Tool.

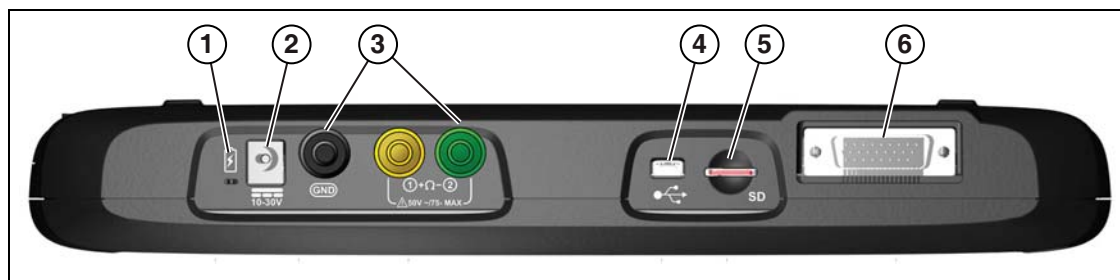

Figure 2-2 Top view

Item	Description
1	Battery Status Indicator LED <ul style="list-style-type: none"> • Green - battery is fully charged • Red - battery is charging • Amber - indicates there is a battery issue (correct before operating)
2	DC Power Supply Jack - AC power supply connection
3	Scope/Multimeter Jacks - Scope and multimeter lead connections
4	Mini USB Jack - USB cable connection used to connect the Diagnostic Tool to a personal computer
5	Micro secure digital (uSD) Card - contains operating system programming. IMPORTANT The uSD card must be installed for the Diagnostic Tool to operate. Do not remove the uSD card while the Diagnostic Tool is powered on.
6	Data Cable Connector - Data cable connection used to connect the Diagnostic Tool to a vehicle data link connector

2.3 Battery Pack and Stand



Figure 2-3 Rear view

Item	Description
1	Built in-Stand (shown closed) - The built-in stand extends from the back of the Diagnostic Tool and clips into the Diagnostic Tool for storage.
2	Battery Cover

2.4 Power Sources

Your Diagnostic Tool can receive power from any of the following sources:

- [Internal Battery Pack](#)
- [AC Power Supply](#)
- [Vehicle Power](#)

2.4.1 Internal Battery Pack

The Diagnostic Tool can be powered from the internal rechargeable battery pack. A fully charged battery provides sufficient power for about 3 hours of continuous operation.

Battery charging occurs when the Diagnostic Tool is connected to the AC Power Supply and to a live AC power source.

The Battery Status Indicator LED (located next to the DC power supply jack) indicates battery status ([Figure 2-3](#)).

- **Green** - indicates battery is fully charged
- **Red** - indicates battery is charging
- **Amber** - indicates a battery issue. This is usually caused by excessive battery temperature (above 104°F/40°C), which disables charging. Allow the Diagnostic Tool to cool down before continuing operation.

2.4.2 AC Power Supply

The Diagnostic Tool can be powered from a standard AC outlet using the AC power supply. The connector on the end of the output cable of the AC power supply attaches to the DC power supply input jack on top of the Diagnostic Tool. Use only the AC power supply provided.

IMPORTANT:

Never connect the AC power supply to the DC power supply input on the Diagnostic Tool when the Diagnostic Tool is communicating with a vehicle.

2.4.3 Vehicle Power

All OBD-II/EOBD vehicles have vehicle battery power (B+) available on the DLC. The Diagnostic Tool is powered through the Data Cable when connected to the vehicle DLC. A green LED indicator on the DLC end of the data cable, illuminates when power is being supplied to the cable. If the LED fails to illuminate, check that the data cable is properly connected and then check the DLC power circuit. See [Data Cable Connection](#), on page 14 for additional data cable information.

An optional power cable is required when testing non-OBD-II/EOBD models that do not have vehicle battery power (B+) available on the DLC. Contact your sales representative for availability.

IMPORTANT:

Never connect the optional power cable to the DC power supply input on the Diagnostic Tool when the Diagnostic Tool is communicating with a vehicle.

2.5 Technical Specifications

Item	Description / Specification
Touch Screen	Resistive Touch Panel
Display	8.0 inch diagonal, Color LCD
	800 x 480 resolution SWVGA
Meter	Category 1
Battery	Rechargeable lithium-ion battery pack
	Approximately 3 hour run time
	Approximately 5 hour charge time
Power Supply	Supply Rating; 15VDC, 2A
DC Operating Voltage	10 to 30VDC
Width	11.06 in. (281.0 mm)
Height	6.29 in. (160.0 mm)
Depth	1.58 in. (40.3 mm)
Weight (including battery):	2.65 lb (1.20 kg)
Operating Temperature Range (ambient)	At 0 to 90% relative humidity (non-condensing) 32 to 113°F (0 to 45°C)
Storage Temperature (ambient)	At 0 to 70% relative humidity (non-condensing) -4 to 140°F (-20 to 60°C)
Operating Altitude	Maximum 2000 m
Environmental Conditions	This product is intended for indoor use only
	This product is rated for Pollution Degree 2 (normal conditions)

Basic Operation and Navigation

This chapter describes basic Diagnostic Tool operation, navigation, screen layout, icon functions, and screen messages. Before you operate the Diagnostic Tool, make sure the battery pack is fully charged or the Diagnostic Tool is powered by the AC power supply.

3.1 Turning On/Off and Emergency Shutdown

The following sections describe how to turn the Diagnostic Tool on and off and how to perform an emergency shutdown.

3.1.1 Turning On

The Diagnostic Tool will automatically turn on and open the Home screen ([Figure 3-1](#)) when power is supplied through the Data Cable or by the AC Power Supply. If the Diagnostic Tool does not automatically turn on, press and release the Power button on the front of the Diagnostic Tool to turn the Diagnostic Tool on.

3.1.2 Turning Off

IMPORTANT:

All vehicle communication must be terminated **BEFORE** turning off the Diagnostic Tool. A warning message displays if you attempt to turn the Diagnostic Tool off while communicating with the vehicle. Forcing a shut down while communicating may lead to ECM problems on some vehicles. Never disconnect the Data Cable when the Diagnostic Tool is communicating with the vehicle ECM.

**To turn off the Diagnostic Tool:**

1. Press the **N/X** button or select the **Back** or **Home** icon to navigate to the Home screen.
The “stopping communication” message appears briefly before the Home screen displays.
2. Disconnect the Diagnostic Tool Data Cable from the vehicle.
3. Press and release the **Power** button.
A confirmation screen displays.
4. Press the **Y/✓** button or select **OK** from the menu to turn the Diagnostic Tool off. To continue operating, press the **N/X** button or select **Cancel** from the menu.

3.1.3 Emergency Shutdown

IMPORTANT:

Using the emergency shutdown procedure while communicating with the vehicle ECM may lead to ECM problems on some vehicles.

During normal operation turn the Diagnostic Tool off using the *Turning Off* procedure above. The emergency shutdown procedure should only be used If the Diagnostic Tool does not respond to navigation or control buttons or exhibits erratic operation. To force an emergency shutdown, press and hold the **Power** button for five seconds until the Diagnostic Tool turns off.

3.2 Basic Navigation

3.2.1 Home Screen Layout

The Home screen includes a title bar and main body. The Home screen contains icons, one for each of the primary Diagnostic Tool functions.

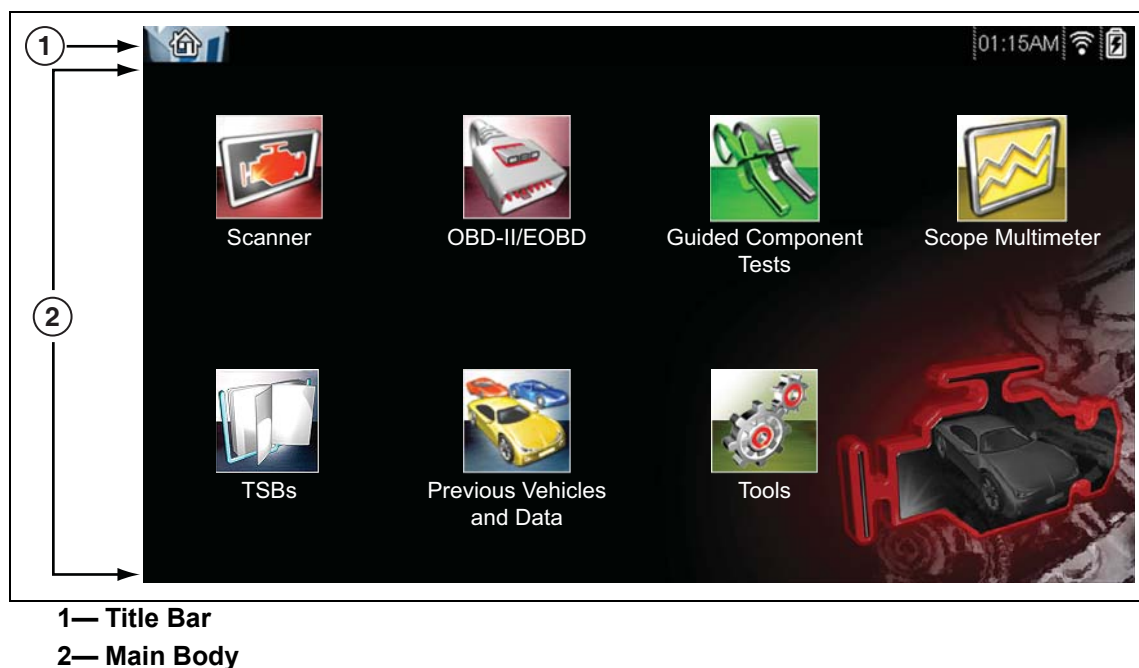

Figure 3-1 Home screen

3.2.2 Title Bar

The title bar at the top of the screen provides basic information about current Diagnostic Tool operating conditions. Title bar options vary depending upon vehicle make and model, what function is active, what test is being performed, or what menu is selected. The title bar contains information only, there are no selectable items.

Elements of the Title bar let you know at a glance:

- What Diagnostic Tool function is currently active.
- The current time.
- Wi-Fi signal strength
- The source and status of the power being supplied to the Diagnostic Tool.





An active function icon is always displayed along the left-hand edge of the Title bar. These icons resemble their Home screen icon counterparts in appearance and color. The name of the function displays to the right of the icon on some screens.

A real time clock displays to the left of the power supply icon. The clock is powered by a dedicated internal battery, so the correct time is maintained even when the main battery pack is discharged. Use the Tools function to set the clock and format how time is displayed. See [Clock Settings](#), on page 132 for additional information.

The Title bar displays other information that varies depending upon what functions are being performed. Other information may include:

- The identification (ID) of the test vehicle
- The name of the active menu or function
- The name of the test being performed

Table 3-1 Title Bar Icons







Icon	Function	Icon	Function
	Full Battery Charge Level - Indicates power is being supplied by the internal battery pack. Horizontal bars diminish as the battery discharges.		Active Vehicle Communication - Indicates the Diagnostic Tool is actively communicating with a vehicle.
	Low Battery Charge Level - Indicates the internal battery pack is low and needs to be recharged immediately. A warning message will also display on the screen when the battery gets low.		Wi-Fi Signal Strength - Indicates signal strength of the wireless network connection. Three bars - indicate full strength signal Zero to 1 bar - indicate weak or no signal
	External Power Connected - Indicates power is being supplied through the data cable connection to a vehicle or by the AC Power Supply and charging the battery pack.		

3.2.3 Home Screen Icons

Each available Diagnostic Tool function is represented by a icon on the home screen. The table below provides descriptions of the icon functions.





Select an icon from the Home screen to start a function. You can also use the control buttons to activate a function, a yellow border around the icon indicates it is highlighted, or in focus. Use the Directional buttons (◀, ▶, ▲, ▼) to highlight the desired function and then press the Y/✓ button to select it. A “please wait” message may display briefly, then automatically clear once the function is loaded and ready for use.

Table 3-2 Home screen icons





Function Name	Function Icon	Description
Scanner		Used to communicate with the electronic control systems of a vehicle. This function allows you to retrieve diagnostic trouble codes (DTCs), view PID data and perform diagnostic tests. See Scanner , on page 16 for details.
OBD-II/EOBD		Allows you to access generic OBD-II/EOBD data and tests without identifying the vehicle being tested. See OBD-II/EOBD , on page 47 for details.
Guided Component Tests		Allows you to perform diagnostic tests for the identified vehicle. See Guided Component Tests , on page 61.
Scope Multimeter		Allows you to perform lab scope, graphing multimeter and digital multimeter tests and measurements. See Scope Multimeter , on page 76.
TSBs		Allows you quick access to vehicle OEM technical service bulletins. See TSBs , on page 57.
Previous Vehicles & Data		Allows you to quickly reconfigure the Diagnostic Tool to a recently tested vehicle and to access saved data files. See Previous Vehicles and Data , on page 71 for details.
Tools		Allows you to adjust Diagnostic Tool settings to your personal preferences and perform other special functions. See Tools , on page 125 for details.

3.2.4 Common Toolbar Control Icons

Common control icon functions are described in the following table. Specific function control icons are described in their applicable chapters. Displayed control icons vary depending on the active function or test. Select a control icon on a screen to activate a control function. You can also use the control buttons to activate a function, a yellow border around the icon indicates it is highlighted, or in focus. Use the Directional buttons (◀, ▶, ▲, ▼) to highlight the desired function and then press the icon, or the Y/✓ button to select it.

Icon	Function	Icon	Function
	Back - Returns to the previously viewed screen. Icon is located on the left-hand edge of the toolbar.		Record - Indicates the data being displayed is paused and not being updated. Selecting resumes data collection.
	Home - Returns to the Home screen. Icon is located next to the Back icon on the left side of the toolbar.		Tools - Opens the tools menu.
	Save - Writes data from buffer memory to a file. The saved “movie” file can be accessed for future reference by selecting Previous Vehicles and Data > View Saved Data .		—

The icons below are used to navigate through paused or saved data (“movie”) files during playback.

Icon	Function	Icon	Function
	Step Forward - allows forward movement in singular steps. To quickly step forward, select this icon (yellow frame appears) then press and hold the Y/✓ button. (Note: To quickly step forward during Scanner data playback, press and hold the icon down until a red frame appears around the icon.)		Step Back - allows backward movement in singular steps. To quickly step backward, select this icon (yellow frame appears) then press and hold the Y/✓ button. (Note: To quickly step backward during Scanner data playback, press and hold the icon down until a red frame appears around the icon.)
	Skip Forward - allows forward movement in multiple steps. To quickly skip forward, select this icon (yellow frame appears around icon) then press and hold the Y/✓ button		Skip Back - allows backward movement in multiple steps. To quickly skip backward, select this icon (yellow frame appears around icon) then press and hold the Y/✓ button.

3.2.5 Scroll Bar

A vertical scroll bar appears along the right-hand edge of the screen when additional data expands above or below what is currently on the screen (Figure 3-2).

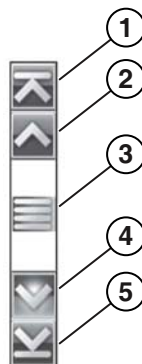

Figure 3-2 Scroll bar

- 1— **Beginning** - Moves to beginning of data displayed.
- 2— **Step up** - Moves up one increment of the data displayed.
- 3— **Slider (position indicator)** - Select and drag the **Slider** to scroll through data. The slider indicates the relative position of the current screen to the total available data.
- 4— **Step down** - Moves down one increment of the data displayed.
- 5— **End** - Moves to end of data displayed.

The Up (▲) and Down (▼) directional buttons can also be used to move through the data one line at a time. Press and hold a directional button to rapidly scroll through data.

3.3 Screen Messages

3.3.1 System Messages

There are four types of system messages that may be displayed:

Message Type	Description
Loading and Connecting	Loading and connecting messages display when the Diagnostic Tool is performing an internal operation, such as loading a database, establishing communications with the vehicle, or initiating a test. The message automatically clears once the internal operation is complete.
Confirmation	Confirmation messages inform you when you are about to perform an action that cannot be reversed or when an action has been initiated that requires a confirmation to continue. When a response is not required, the message displays briefly, then disappears.
Warning	Warning messages inform you when completing the selected action may result in an irreversible change or in the loss of data. A confirmation is required to continue.
Error	Error messages inform you when a system or procedural error has occurred, for example if the data cable becomes disconnected during operation.

3.3.2 Communication Messages

When “no communication” messages are displayed, it indicates the Diagnostic Tool and the vehicle electronic control module are not communicating.

The following conditions cause “no communication” messages to display:

- The Diagnostic Tool is unable to establish a communication link with the vehicle.
- The vehicle is not equipped with the system that was selected.
- There is a loose connection.
- There is a blown vehicle fuse.
- There is a wiring fault on the vehicle.
- There is a circuit fault in the data cable or adapter.
- Incorrect vehicle identification was entered.

Refer to the Vehicle Communication Software manuals for manufacturer-specific problems.

3.4 Data Cable Connection

Connection of the data cable to the Diagnostic Tool and vehicle data link connector (DLC) is required for Scanner and OBD-II/EOBD testing.

IMPORTANT:

Use the approved cables and accessories for your diagnostic tool. Cable length must not exceed 114.17 inches (2.9 meters).

Depending on the vehicle, the supplied DA-4 data cable may be used alone or may require optional adapters.

- **All OBD-II/EOBD compliant vehicles** - Use the supplied DA-4 data cable. The 26-pin end of the cable attaches to the data cable connector on the top of the Diagnostic Tool. The 16-pin end connects to the vehicle DLC.
- **All OBD-I (non-OBD-II/EOBD) compliant vehicles** - Use the supplied DA-4 data cable with the optional DA-5 adapter and a manufacturer specific adapter. The 26-pin end of the cable attaches to the data cable connector on the top of the Diagnostic Tool. The 16-pin end connects to the DA-5 adapter, the DA-5 adapter connects to the manufacturer specific adapter and then connects to the vehicle DLC.

On-screen cable and adapter connection instructions are provided while using the Scanner and OBD-II/EOBD functions. The instructions may also include the location of the vehicle DLC ([Figure 3-3](#)).

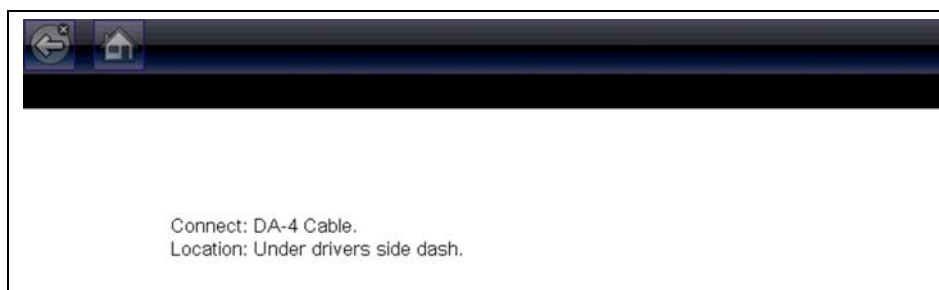

Figure 3-3 Vehicle connection data cable message

For data cable vehicle power connection information, see [Vehicle Power](#), on page 6.

**NOTE:**

The data cable, includes an LED light on the vehicle DLC connector end, that can be used for locating the vehicle DLC. The LED light is powered by the diagnostic tool battery.

**To connect the data cable to the vehicle:**

1. After identifying a vehicle using the Scanner or OBD-II/EOBD function, review the on-screen information for data cable usage and DLC location ([Figure 3-3](#)).
2. Connect the data cable to the diagnostic tool.
3. If needed, press the LED light button switch on the end of the cable to turn the LED light on, and locate the DLC.
4. Turn the vehicle ignition on.
5. Select **Continue** once the data cable is connected.

The Diagnostic Tool establishes communication with the vehicle, then displays a list of available tests. If the Diagnostic Tool is unable to establish a communications link, a “no communications” message displays.

This chapter describes the basic operation of the Scanner function.

The **Scanner** icon is located on the Home screen.



The Scanner function allows your diagnostic tool to communicate with the electronic control systems of a vehicle. This allows you to retrieve diagnostic trouble codes (DTCs), view PID data and perform diagnostic tests.

4.1 Screen Layout and Toolbar Icons

The following screen layout and toolbar controls apply to both the Scanner and the OBD-II/EOBD functions.

4.1.1 Screen Layout

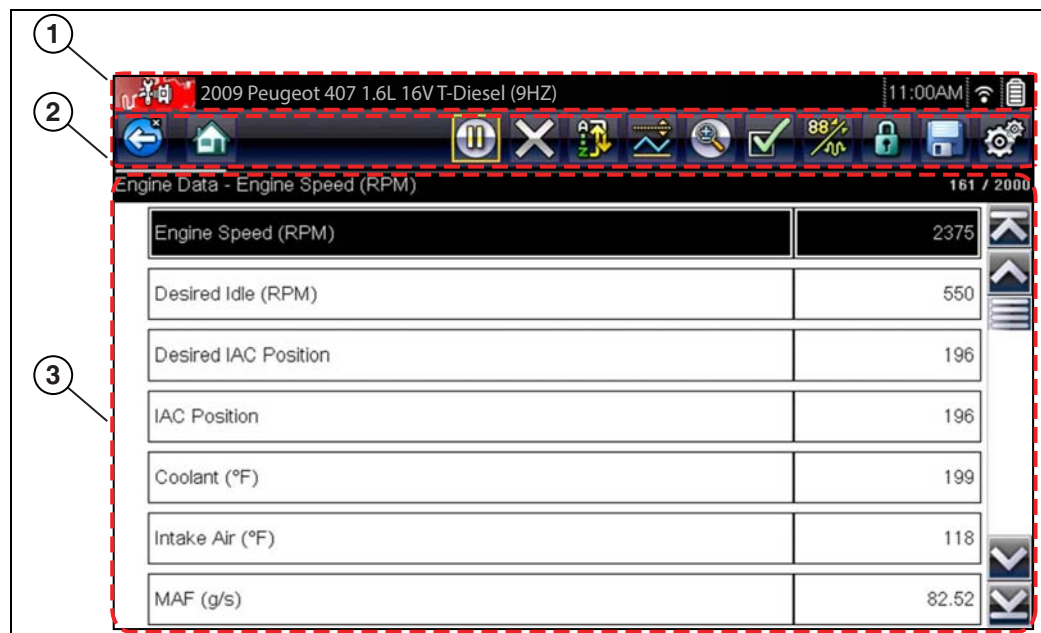









- 1— **Title bar**—shows active test, vehicle and diagnostic tool status
- 2— **Toolbar**—contains control icons
- 3— **Main body**—displays menus, PID and test data

Figure 4-1 Screen layout

The Title bar appears for all functions and displays information only, there are no selectable items. Refer to [Title Bar](#), on page 10 for details.

4.1.2 Scanner Control Icons

The scanner toolbar contains control icons. Control icons may vary depending on the active function or test. A yellow frame surrounding an icon (highlighted), indicates it is selected. Other control icons (not shown) are described in [Common Toolbar Control Icons](#), on page 12.

Icon	Function	Icon	Function
	Pause - Indicates PID data from the vehicle is being displayed. Selecting pauses data collection.		Custom Data List - Opens a menu for selecting which PIDs display in the list.
	Clear - Erases all the PID data in the buffer and begins a new recording. Selecting opens a confirmation message.		Change View - Changes display options between PID list or graph displays.
	Trigger - Opens a menu that allows you to set, arm, and clear threshold values that automatically trigger PID data to be saved from buffer memory to a file.		Lock/Unlock - Locks or unlocks the highlighted parameter. Locked PIDs move to the top of the list and do not scroll as you move through the data.
	Zoom - Incrementally increases and decreases the scale of the data being displayed.		Sort - Determines the order in which PIDs are listed on the screen.

4.2 Scanner Demonstration Program

The Scanner demonstration program contains actual ECM PID data that allows you to navigate and become familiar with the many capabilities of the Scanner function without actually connecting to a vehicle. The following sections in this chapter provide detailed information on navigating through the Scanner function and various menus. As you navigate through the Demonstration program, refer to the applicable section for additional information.



To start the demonstration program:

1. From the Home screen, select the **Scanner** icon.
The manufacturer menu displays.
2. Select the **Demonstration** icon.

IMPORTANT:

Do not connect a vehicle to the diagnostic tool while using the Demonstration program.

3. Follow the on-screen instructions and make the selection as needed until the confirmation screen displays.
4. Select **OK** on the confirmation screen to load the demonstration database.
A message displays "Demo mode: Do not connect to vehicle."
5. Select **Continue**.
A systems menu, which shows all of the systems available for testing, displays.
6. Select a system from the menu, then select submenus as applicable to display the desired demonstration information.

4.3 Scanner Operation



Scanner Operation (Quick Reference)

1. Connect the data cable to the vehicle, and diagnostic tool.
Note: If the diagnostic tool is turned off, when the OBD-II data cable is connected to the vehicle DLC, the diagnostic tool will automatically turn on.
2. Turn the diagnostic tool on (if required).
3. Turn the vehicle ignition switch on.
4. Select **Scanner** from the Home screen.
5. Select the vehicle year and make
6. Select **Auto** or **Manual ID** and enter the vehicle information at the screen prompts to continue.
7. Select a **System** to test.
8. Select a **Test** to be performed.



NOTE:

The above information applies to most OBD-II vehicles.

4.3.1 Connecting the Data Cable

Connection of the data cable to the diagnostic tool and vehicle DLC is required for Scanner testing, see [Data Cable Connection](#), on page 14.

4.3.2 Vehicle Identification

The vehicle must be correctly identified for the diagnostic tool to communicate and display data correctly. Menus and navigation will vary by vehicle.



Identifying a vehicle:

**NOTE:**

Menus and navigation will vary by vehicle.

1. Select **Scanner** from the Home screen.
A list of vehicle manufacturers (make) displays ([Figure 4-2](#)).
The list includes Demonstration, which opens the Demonstration program (see [Scanner Demonstration Program](#), on page 17).
2. Select a **vehicle manufacturer** ([Figure 4-2](#)).

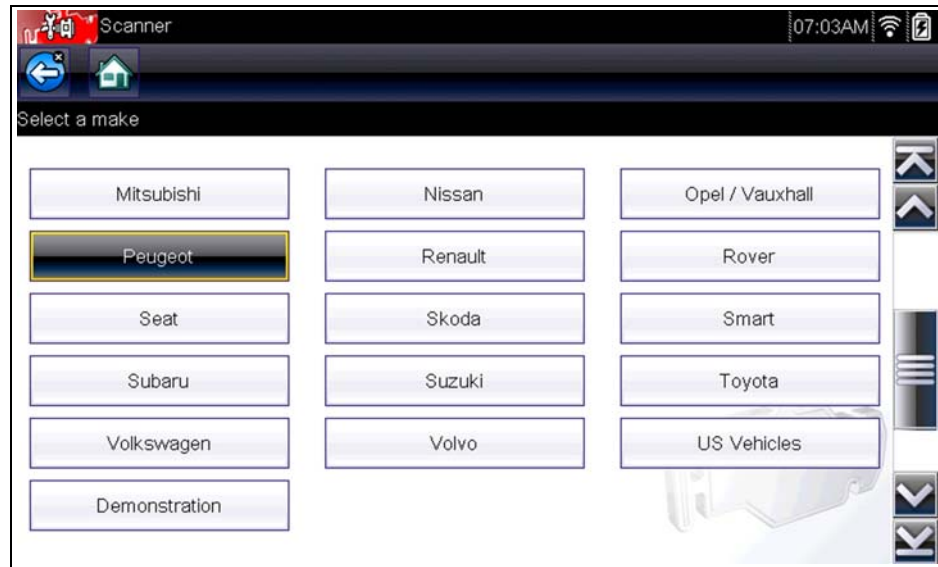

Figure 4-2 Manufacturer list

A model year menu displays.

3. Select the **vehicle year**.
4. If the vehicle supports automatic identification, a menu choice will display providing the option to either "Auto ID the vehicle" or "Manual ID the vehicle".
 - Selecting Auto ID will automatically enter the vehicle's information, and then display the vehicle confirmation screen, see step 7.
 - Selecting Manual ID will display a list of vehicle models, see step 5.
5. Select the **vehicle model**.
6. Several selections may be required to get to the vehicle confirmation screen. If applicable, make any other additional menu sections that may be required to select the vehicle.
7. The vehicle confirmation screen displays (Figure 4-3).
8. Select **OK** to confirm the vehicle (Figure 4-3).

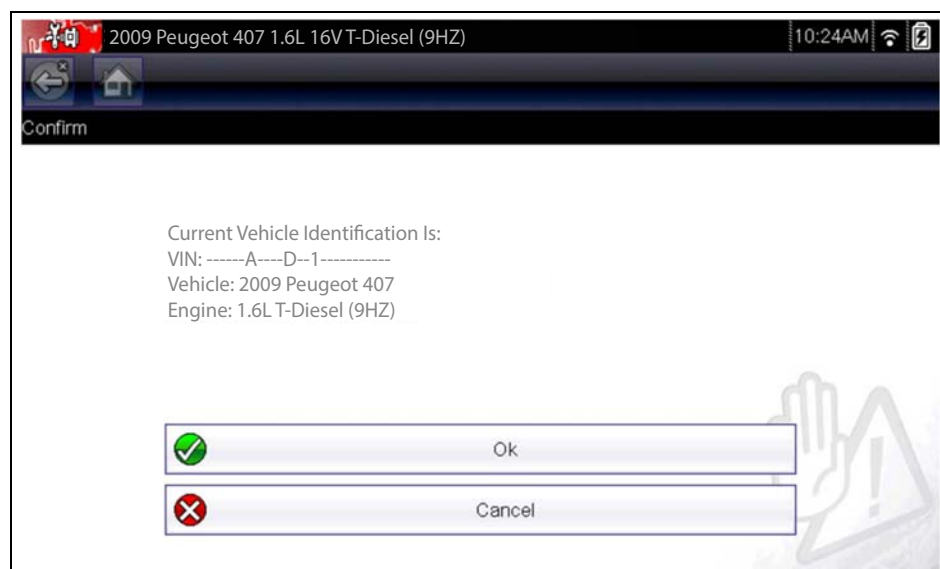

Figure 4-3 Vehicle confirmation screen

4.3.3 System Selection

After a vehicle is identified, a menu of available systems, and options are displayed (Figure 4-4).

**NOTE:**

Only the systems and options available for the vehicle are included in the menu list.

Select a system or option (Figure 4-4).



Figure 4-4 Typical systems menu

If a system (e.g. Engine, Transmission, Antilock Brakes, etc) is selected, the diagnostic tool may establish communication with the vehicle, then display the system main menu (available tests) (Figure 4-5). For sub-menu option information, see [System Main Menu Options](#), on page 21.



Figure 4-5 System main menu

4.3.4 System Main Menu Options

Once a System is selected (e.g. Engine, Transmission, Antilock Brakes, etc) is selected, the diagnostic tool may establish communication with the vehicle, then display the System Main Menu (available tests).

**NOTE:**

Menus and navigation will vary by vehicle.

The System Main Menu may include:

- **Codes Menu**—displays diagnostic trouble code (DTC) records from the vehicle electronic control module. Selecting may open a submenu of viewing options.
- **Clear Codes**—erases DTC records and other data from the ECM. This selection is found on a Codes submenu for some models.
- **Data Display**— displays PID data from the vehicle electronic control module. Selecting may open a submenu of viewing options.
- **Functional Tests**—provides specific subsystem tests. The tests vary depending on the manufacturer and model.
- **Actuator Tests**—similar to functional tests, checks the operation of certain actuators, such as solenoid valves and relays.
- **Memory Resets**—allows you to reprogram adaptive values for certain components after making repairs. Selecting opens a submenu. These options are found on the Functional Tests Menu for some models.
- **System Tests**—provides specific subsystem testing. Performing these tests is similar to functional tests.
- **Generic Functions**—lets you access certain available Generic OBD II functions from a proprietary menu (1996 and newer vehicles only).
- **Troubleshooter**—provides step-by-step procedures, integrating PIDs and retrieving trouble codes when appropriate, for specific symptoms of the identified vehicle.

The following sections, describe some of the System Main Menu items listed above.

Codes Menu

This selection may appear as Codes, Codes Menu, Codes Only, Codes (No Data), Service Codes or something similar on the menu. Selecting opens a list of viewing options that includes:

- [Display Codes](#), on page 22
- [Clear Codes](#), on page 23
- [Freeze Frame/Failure Records](#), on page 23

Display Codes

This function opens either a list of diagnostic trouble codes (DTCs) stored in the selected vehicle electronic control module (ECM), or a submenu of DTC viewing options. The code list includes the DTC and a brief description (Figure 4-6).

If SureTrack® (optional) is active and data is available for a selected DTC, additional troubleshooting information from SureTrack (e.g. Common Replaced Parts data (Figure 4-6), Real Fix and Related Fixes) will also be available. For additional information about using SureTrack, see [SureTrack](#), on page 34.

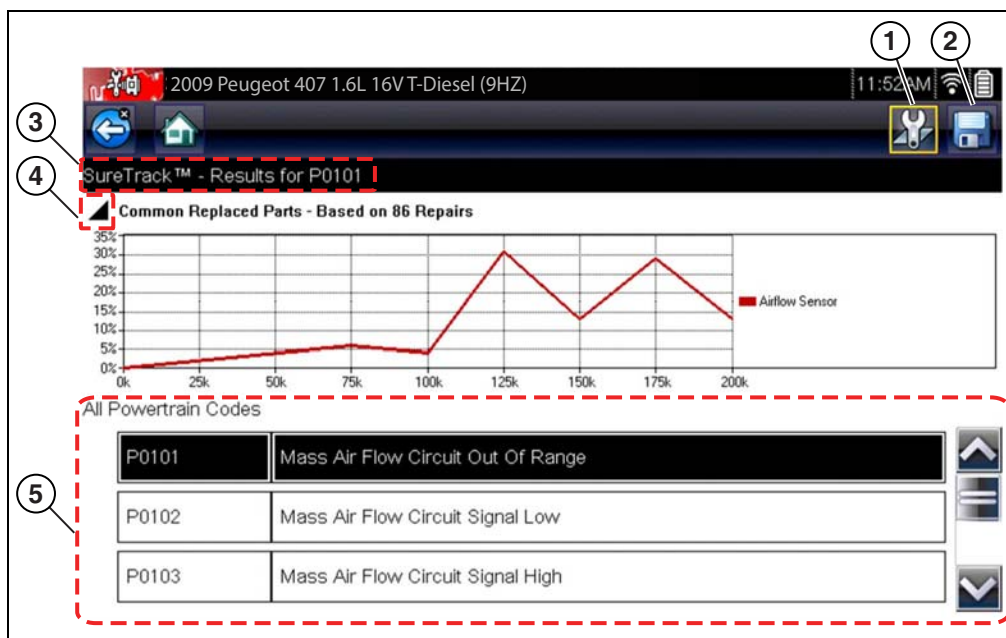

Figure 4-6 DTC results

- 1— **Fix It! Icon** — opens SureTrack Dashboard
- 2— **Save Icon** — saves the displayed DTCs to an (.XML) file
- 3— **SureTrack Status Bar** — displays active SureTrack status or result
- 4— **Common Replaced Parts Graph Icon** — toggles graph display on/off
- 5— **DTC Results List** — displays current DTCs

Submenu options may include:

- **Trouble Code Information**—opens a list of codes in ECM memory
- **History Codes**—opens a list of codes whose symptoms are not currently present. History codes indicate an intermittently occurring problem.
- **Failed This Ignition**—opens a list of codes that set during the current ignition cycle.
- **MIL SVS or Message Requested**—displays ECM requests to turn on the malfunction indicator lamp (MIL) or service vehicle soon (SVS) lamp, or display a driver information alert.
- **Last Test Failed**—displays a complete list of failed tests.
- **Test Failed Since Code Cleared**—displays a list of tests that failed since the last time codes were cleared from ECM memory.

Code Scan

See [Vehicle Code Scan / \(ALTUS™\)](#), on page 40.

Clear Codes

The diagnostic tool clears codes from the vehicle electronic control module memory on most vehicles. If this function is not available on the test vehicle, Clear Codes does not appear as a menu option.

**NOTE:**

Clear Codes is also available from OBD-II Health Check (see [OBD Health Check](#), on page 48).

**To clear codes:**

1. Select **Clear Codes** from the Codes Menu.
A confirmation message displays.
2. Make sure any conditions shown on the confirmation message are met, then select **Yes**.
A “codes cleared” message displays once the operation is complete.
3. Select **Continue** to return to the Codes Menu.

IMPORTANT:

Clearing codes erases all temporary ECM information, including Freeze Frame/Failure Records. Make sure no vital diagnostic information will be lost before clearing codes.

Freeze Frame/Failure Records

This selection displays the DTC that was set, along with corresponding data, when the ECM commanded the malfunction indicator lamp (MIL) to turn on.

Saving Codes

When viewing individual system codes (e.g. engine, transmission) selecting the **Save** icon from the toolbar saves the results as report formatted file.

The saved file(s) can be viewed using two methods:

- On the diagnostic tool - See [View Saved Data](#), on page 72.
- In report format using ShopStream Connect - See [Printing the \(Code Scan\) Vehicle System Report](#), on page 168.

Data Display

Select **Data** to view PID data from the vehicle ECM. In data display mode the screen has a toolbar and a main body (Figure 4-7).

Engine Data - Engine Speed (RPM)		161 / 2000
Engine Speed (RPM)	2375	↑
Desired Idle (RPM)	550	↑
Desired IAC Position	196	☰
IAC Position	196	
Coolant (°F)	199	
Intake Air (°F)	118	↓
MAF (g/s)	82.52	↓

Figure 4-7 Data display screen

The toolbar control icons are described in [Scanner Control Icons](#), on page 17 and [Common Toolbar Control Icons](#), on page 12.

During data display the main body of the screen is divided into two columns; the left-hand column has a description of the parameter and the right-hand column shows the parameter value or state. Parameters are listed in the order in which they are transmitted by the ECM, so expect variations between years, makes, and models.

Up to three parameters can be locked, or fixed, at the top of the list. Locked parameters do not change as you scroll through the parameter list. The **Lock/Unlock** icon on the toolbar selects which parameters are fixed (see [Locking Parameters](#), on page 26).

Displayed data may also be paused or saved for detailed review and future reference, see [Saving Files](#), on page 29 and [Pausing and Reviewing Data Files](#), on page 30.

Customizing the Data List

The **Custom Data List** icon on the toolbar is used to determine which specific parameters display. Minimizing the number of parameters on the data list allows you to focus on any suspicious or symptom-specific data parameters. You can add or remove most parameters from the list. Certain vital parameters may not be removed. These appear in gray at the top of the list along with a lock icon, and they cannot be selected.



NOTE:

Limiting the number of parameters that display to those that apply to a particular situation results in a faster data refresh rate, and reduces the amount of memory used for saved files.





To create a custom data list:

1. Select the **Custom Data List** icon on the toolbar.

The data selection screen displays and selection icons appear. Check marks to the left of the parameter description indicate which parameters are selected for display. A second smaller check box indicates a parameter that is locked.

The toolbar icons provide options for selecting and deselecting parameters to include or remove from the custom data list:

Icon	Description
	Select/Deselect , use to mark individual parameters to hide or display. Locked parameters cannot be deselected.
	Select All/Deselect All , use to hide or display all of the parameters in the list. Locked parameters cannot be hidden. Items at the top of the list that cannot be highlighted are locked and cannot be turned off.

2. Create a custom data list by selecting (check mark box by parameter name) the parameters to include.
3. Select **Back** to display the updated data list.

Changing Screen Views

Selecting the **View** icon opens a drop-down menu of options:

- PID List
- 1 Graph
- 2 Graph
- 4 Graph

The PID (parameter identification) List view is a 2-column display with the name of the parameters in the left column and their current values in the right column ([Figure 4-8](#)).

The 1, 2, and 4 Graph views divide the screen horizontally to simultaneously display data graphs for the indicated number of parameters ([Figure 4-8](#)). Use the scroll bar or the **up** (▲) and **down** (▼) icons to view other parameters in the list.

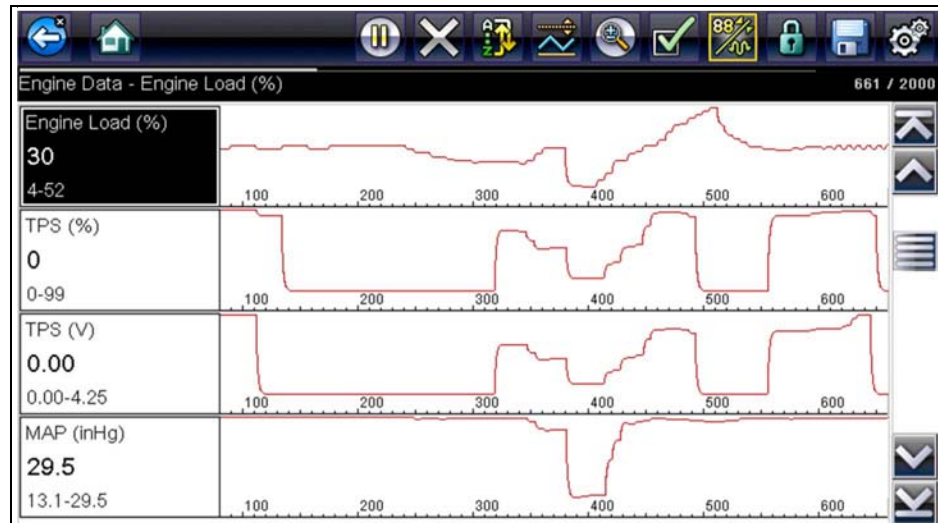

Figure 4-8 Four graph view



NOTE:

Any previously set conditions, such as held data or locked lines of data, remain in effect when the screen view is changed.

Locking Parameters

Use the **Lock/Unlock** icon to hold selected lines of the data in place and prevent them from scrolling, or to release previously locked lines of data. Up to three lines of data may be held at a time. This feature allows you to position related parameters together, making it easier to monitor their values and spot inconsistencies.

Locked parameters display as the top frames on the main body of the display screen, as well as at their usual position within the data list (Figure 4-9). A lock icon appears to the left of the parameter name to indicate it is locked.



To lock parameters:

1. Highlight the parameter to be locked.
2. Select the **Lock/Unlock** icon on the toolbar to lock it.
A copy of the locked parameter is now shown at the top of the data list, and a lock icon appears alongside the parameter name.
3. Highlight and select additional parameters to lock.

Up to three parameters can be locked at a time. Once locked, a parameter remains locked until it is manually unlocked, or communication with the vehicle is stopped.

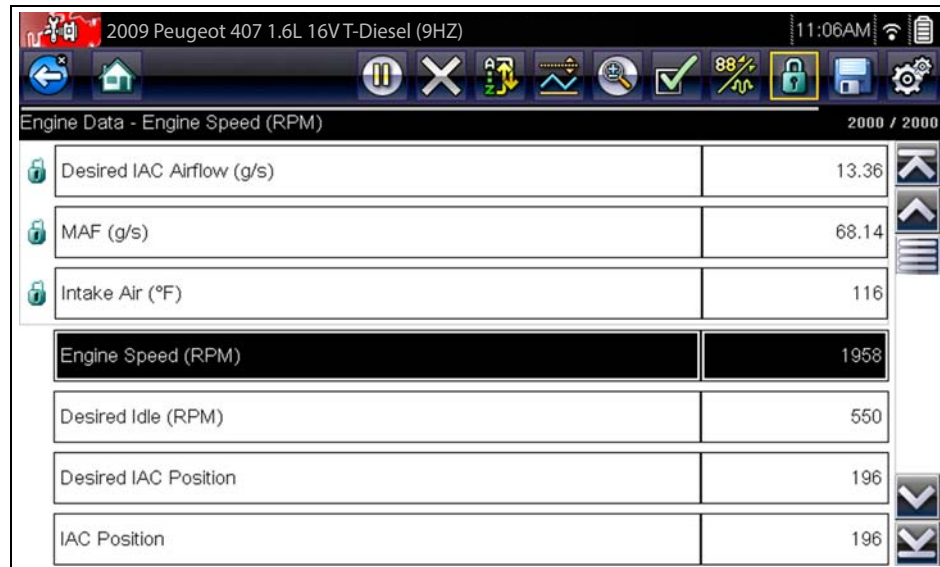

Engine Data - Engine Speed (RPM)		2000 / 2000
Desired IAC Airflow (g/s)	13.36	
MAF (g/s)	68.14	
Intake Air (°F)	116	
Engine Speed (RPM)	1958	
Desired Idle (RPM)	550	
Desired IAC Position	196	
IAC Position	196	

Figure 4-9 Locked parameters



NOTE:

If three parameters are locked, one of them must first be unlocked before another parameter can be locked.



To unlock parameters:

1. Scroll through the data list and highlight the parameter to be unlocked, or released.
2. Select the **Lock/Unlock** icon on the toolbar.
The released parameter and the lock icon disappear from the list at the top of the data list.
3. Repeat Step 1 and Step 2 to release other parameters if needed.

Setting Trigger Levels

The trigger icon allows you to configure the diagnostic tool to automatically save PID data from buffer memory to a file when a parameter value crosses a threshold. When triggering is armed, a "Trigger event" pauses data collection and saves data to a file.

Selecting the **Trigger** icon opens a menu that includes:

- **Set Trigger**—establishes upper and lower signal values to initiate an event capture for the highlighted parameter.
- **Arm Trigger**—activates the diagnostic tool to capture an event when the signal crosses a threshold value.
Trigger lines change colors to indicate the trigger is armed.
- **Clear All Triggers**—deletes all previously set trigger levels.

If triggers are set the menu options are:

- **Clear Trigger**—deletes set trigger levels for the highlighted parameter.
- **Disarm Trigger**—de-activates event capture capability.

- **Clear All Triggers**—deletes all previously set trigger levels.



To set trigger levels:

1. Highlight the parameter to be used for triggering the recording.
2. Select the **Trigger** icon.
3. Select **Set Trigger** from the drop-down menu.

A graph of the highlighted parameter with a trigger toolbar above it fills the main body of the screen (Figure 4-10).

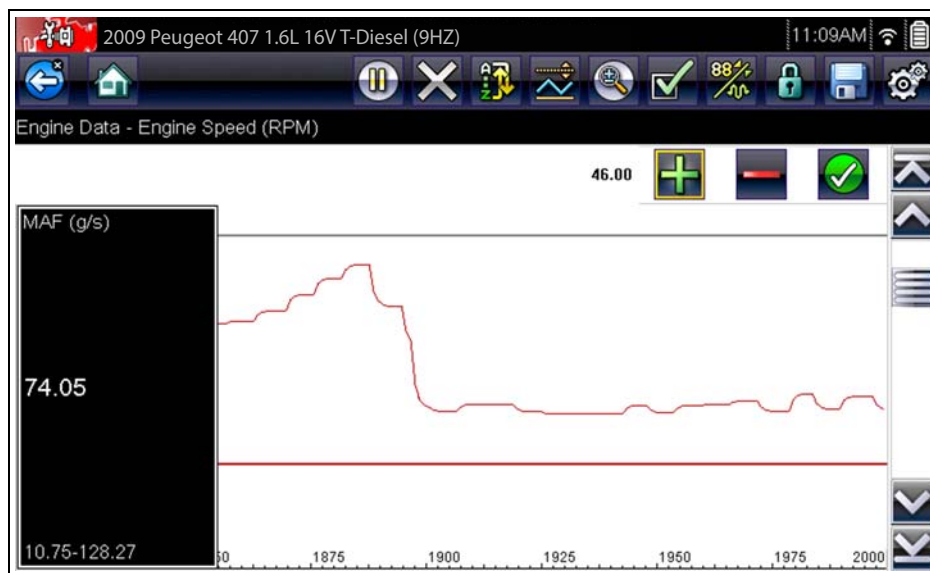

Figure 4-10 Trigger set screen

The trigger level line displays as a solid line running horizontally across the data graph. An upper and lower trigger level must be set, the upper level is set first.

4. Select the plus (+) and minus (–) icons on the toolbar, or use the up ▲ and down ▼ arrow buttons to position the upper trigger level to where you want it on the graph.
5. Select ✓ on the toolbar, or press the **Y/✓** button, to set the upper threshold. A lower trigger level line now appears at the mid-point of the graph.
6. Select the plus (+) and minus (–) icons on the toolbar, or use the up ▲ and down ▼ arrow buttons to position the lower trigger level line to where you want it on the graph.
7. Select ✓ on the toolbar, or press the **Y/✓** button, to set the lower threshold.

The display returns to the PID data view and the trigger points appear as horizontal lines across the designated parameter graph. Repeat this procedure to establish trigger points for other parameters if desired. Once armed, any data points that register outside of your set conditions pause data collection and save data to a file.



NOTE:

Only three parameters can have trigger levels set at one time, but only one of the conditions needs to be satisfied for triggering to occur.

**To arm triggers:**

1. Select the **Trigger** icon on the toolbar.
2. Select **Arm Triggers** from the drop-down menu.

The trigger lines on the data graphs change color to indicate an armed condition.

Triggers for all of the graphs are armed simultaneously. Once triggering is armed, it remains in that state until you switch it off. If trigger settings are modified or are added for other parameters, they are armed as soon as you exit the setting screen.

Saving and Reviewing Scanner / OBD-II/EOBD Data Files

The following procedures are used when saving and reviewing data files for Scanner and OBD-II/EOBD.

Saving Files

During normal operation, data from the vehicle's ECM is continuously being stored in buffer memory as it is displayed onscreen. Buffer memory is limited to a predetermined "total" size and is displayed on the counter (located below the toolbar on the right side of the screen) ([Figure 4-12](#)).

Selecting **Save** writes the stored buffer memory to a file. Saving data is useful when trying to isolate an intermittent problem or to verify a repair during a road test. The saved file can be played back (similar to a movie clip) by selecting **Previous Vehicles and Data > View Saved Data**. See [View Saved Data](#), on page 72 for additional information.

**NOTE:**

The **Save icon** performs the same function as "Save Movie" function choice for the programmable **Shortcut** button, see [Configure Shortcut Button](#), on page 127 for details.

The saved data file can also be downloaded to a personal computer (PC) using the Mini USB jack. Once connected to the PC, the data files can be printed, transferred, and copied using ShopStream Connect. ShopStream Connect is an application that creates an interface between the diagnostic tool and a PC. The ShopStream Connect application is available free online, see the ShopStream Connect website information at the front of this manual for additional information.

The toolbar control icons are described in [Scanner Control Icons](#), on page 17 and [Common Toolbar Control Icons](#), on page 12.

**To save data:**

- Select **Save**.

A save dialog box displays while data is being saved. The data is saved when the message box disappears.

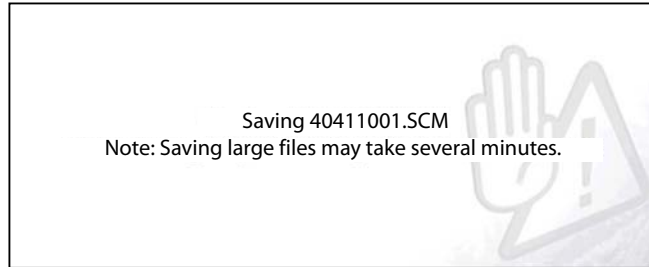

Figure 4-11 Save dialog box

Saving Screens

The **Shortcut** button can be programmed to save a snapshot of a visible screen as a bitmap file, see [Configure Shortcut Button](#), on page 127 for details. The saved file can be viewed by selecting **Previous Vehicles and Data > View Saved Data**, see [View Saved Data](#), on page 72 for additional information.

Pausing and Reviewing Data Files

During normal operation, data from the vehicle's ECM is continuously being stored in buffer memory as it is displayed onscreen. The Pause feature, allows you to temporarily pause data collection to review it in detail.

**To pause and review data**

Toolbar control icons are described in [Scanner Control Icons](#), on page 17 and [Common Toolbar Control Icons](#), on page 12.

1. While viewing data, select the **Pause** icon.

On the toolbar, the playback control icons are displayed. A counter displays along the right-hand edge of the screen between the toolbar and the main body. A bar graph to the left of the counter shows how much data is in the memory buffer. A slider on the bar graph indicates the position of the current screen in relation to the entire contents of the data buffer.

Use the slider to quickly scroll through the data. Use the control icons to accurately position the cursor. The cursor (vertical line), indicates your position when in the graph mode, appears once you begin navigating ([Figure 4-12](#)).

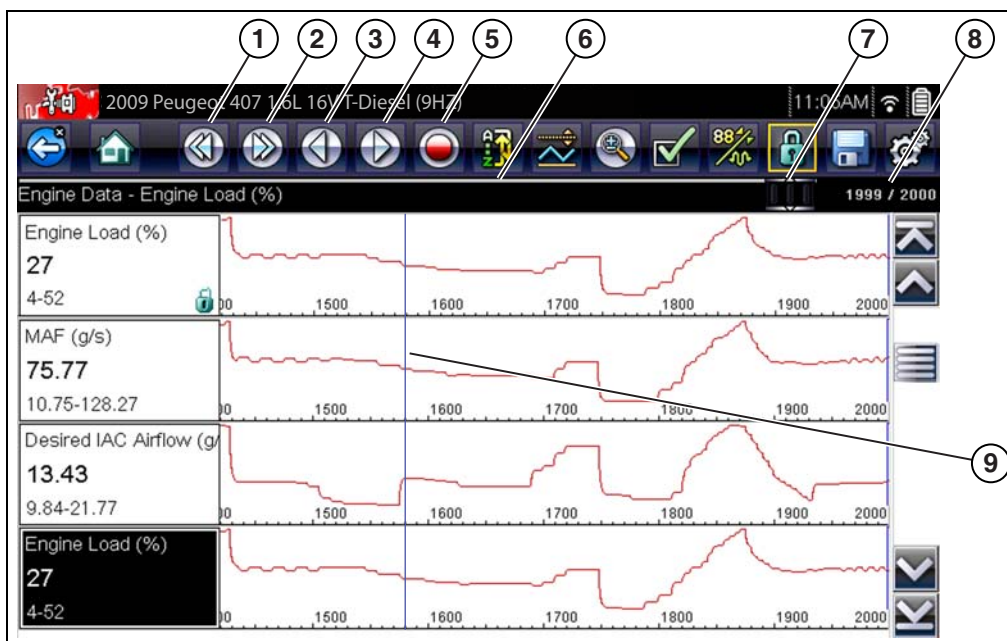

- | | |
|-----------------|---------------------------------------|
| 1— Skip Back | 6— Bar Graph |
| 2— Skip Forward | 7— Slider |
| 3— Step Back | 8— Counter (current position / total) |
| 4— Step Forward | 9— Cursor |
| 5— Record | |

Figure 4-12

2. Scroll up or down to review the list of data.
3. Select the desired control icon to move forward or back incrementally in the selected direction.

**To resume:**

- Select the **Record** icon.

The display changes back to display data and the **Pause** icon is shown on the toolbar. A vertical rule runs through the data graph to indicate data was paused at that point.

**NOTE:**

The **Shortcut** icon can be set to perform the Pause/Play function. See [Configure Shortcut Button](#), on page 127 for additional information.

Functional Tests

The **Functional Tests** selection is used to access vehicle-specific subsystem tests. Available tests vary by manufacturer, year, and model. Only the tests available for the identified vehicle display in the menu.

There are several types of functional tests:

- **Information Tests**—these are read-only tests, like selecting “VIN” from a Functional Tests menu to display the VIN of the identified vehicle.

- **Toggle Tests**—these tests switch a component, such as a solenoid, relay, or switch, between two operating states.
- **Variable Control Tests**—these tests command a certain value for a system or component, such as varying spark timing in 1° increments or EGR valve duty cycle in 10% increments.
- **Reset Tests**—these tests reset the adaptive, or learned, values that are stored in the vehicle electronic control module memory.
- **Scripted Tests**—these tests are software routines that place the vehicle into special operating modes for performing certain repairs, such as bleeding brakes with ABS.

Selecting Functional Tests opens a menu of test options that varies by make, year, and model. Selecting a menu option either activates the test or opens a submenu of additional choices. Follow all screen instructions while performing tests. How and what information is presented on the screen varies according to the type of test being performed and the vehicle being serviced.

Toggle and variable control tests often display functional test controls on the toolbar at the top of the screen with PID data in the main body (Figure 4-13).

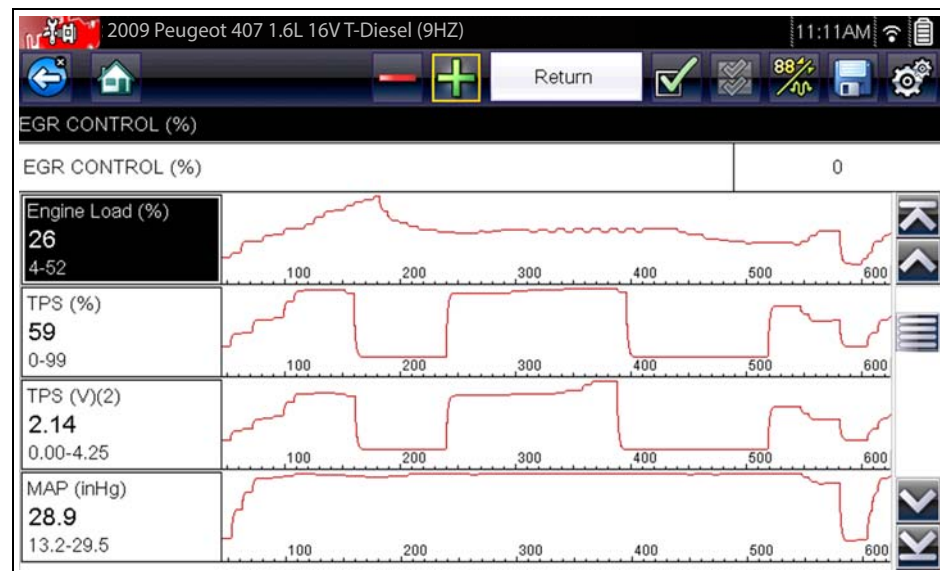

Figure 4-13 Functional test screen

A Test icon on the toolbar activates the test, and a Return, or similarly named, icon cancels the test. For variable control tests, the variable value displays between the main body and the toolbar. Plus and Minus icons on the toolbar increase and decrease the variable value.



A Data List icon, shown to the left, is available on the toolbar for some tests. This feature allows you to change which data list displays in the main body without exiting the functional test. The icon is only available when the test is inactive.

Generic Functions

Generic Functions are used to perform generic OBD-II/EODB tests, for additional information see [OBD-II/EODB](#), on page 47.

Troubleshooter (Fast-Track®)

Fast-Track Troubleshooter is a database of experience-based repair strategies and information, that has been compiled and validated by top-notch technicians. Troubleshooter simplifies the diagnosis process, as it contains information on virtually all common diagnostic trouble code (DTC) problems and driveability symptoms.

Troubleshooter information is organized into a series of diagnostic tips that are designed to quickly lead you to the root cause of a particular problem. The tips are vehicle-specific, which means only tips that relate to the identified vehicle are presented. Selecting opens a menu that may include:

- **Code Tips**—provides detailed information on setting conditions, testing, and interpreting test results for specific codes.
- **Symptom Tips**—provides diagnostic tests and procedures based on vehicle operation.
- **Time Savers**—provides supplemental information, such as firing order and #1 cylinder location, that may be needed to make a diagnosis.
- **Common Problems**—provides advice and remedies for certain “pattern failures” that have been experienced on vehicles of the same model.
- **Tests and Procedures**—explains how to perform certain tests on the specific test vehicle. Some tips provide specifications and installation information as well.
- **Fast-Track Data Scan**—contains information and guidelines on how to validate data readings for certain sensors and actuators, PID data values are provided.
- **Fast-Track Fixes**—provides actual repair information for related repairs.



NOTE:

Troubleshooter appears in a Scanner menu only if tips are available for the system selected on the identified vehicle.

Certain PID data parameter values display directly within the tip when performing Troubleshooter tests and procedures.

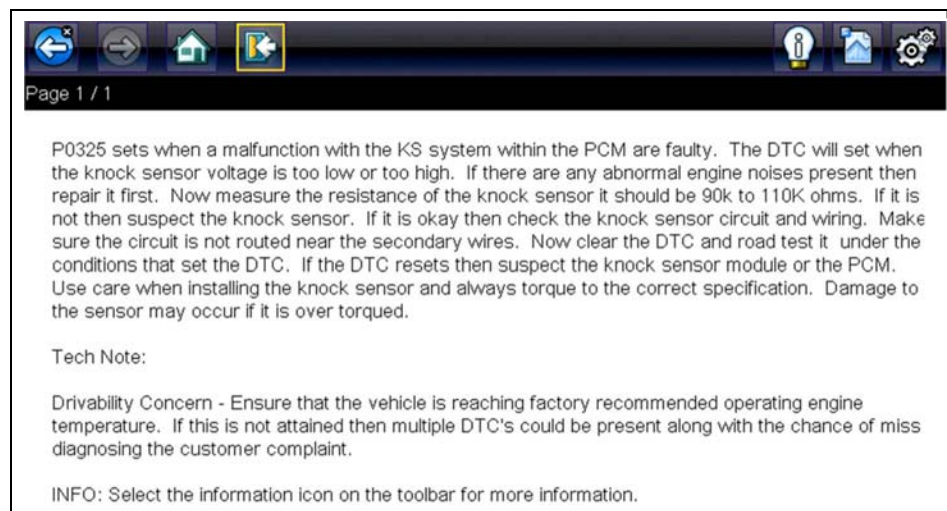

Figure 4-14 Troubleshooter tip

4.4 Exiting Scanner

Scanner function remains open as long as there is an active communication link with the vehicle. You must interrupt this communication link in order to exit from tests and power down the diagnostic tool. A warning message displays if you attempt to shut down while the diagnostic tool is communicating with the vehicle.

NOTE:



Damage to the vehicle electronic control module (ECM) may occur if communication is disrupted. Make sure the data cable is properly connected at all times during testing. Exit all tests before disconnecting the data cable or powering down the diagnostic tool.



To exit the Scanner function:

1. From any active data screen, select the **Back** icon on the toolbar.
A “stopping communications” message briefly displays followed by the Data menu.
2. From the Data Menu, select **Back** on the toolbar.
Again, a “stopping communications” message briefly displays followed by the Main menu.

Now, the diagnostic tool is no longer communicating with the vehicle and it is safe to return to the Home screen and power down the diagnostic tool.

4.5 SureTrack

SureTrack is a comprehensive source of expert knowledge for professional technicians, combining diagnostic experience and detailed parts replacement records. SureTrack will help you improve diagnostic accuracy and reduce repair time.

SureTrack features:

- A Common Replaced Parts graph displaying the parts that are most frequently replaced to successfully complete repairs based on actual vehicle repairs.
- Tips and fixes obtained from completed repairs, validated by SureTrack expert technicians.
- Up-to-the-minute intelligence based on vehicles currently being serviced nationwide.

NOTE:



To access SureTrack, you must have the current software update installed on your scan tool, the Wi-Fi radio turned on and connected to a wireless network. For Wi-Fi setup and connection see, [Configure Wi-Fi](#), on page 133

4.5.1 SureTrack Operation

Before you begin using SureTrack, familiarize yourself with the SureTrack control icons shown below.

Fix It! Icon	Related Tips Icon	Real Fixes Icon	Menu Exit Icon	Common Replaced Parts Graph Icon
Opens the SureTrack dashboard	Displays Related Tips for the selected DTC	Displays Related and Real Fixes for the selected DTC	Exits the SureTrack dashboard	Toggles Common Replaced Parts Graph display on/off

SureTrack repair information may be accessed while reviewing DTC using the Scanner function. As an example, navigate to **Engine > Codes Menu > Display Codes > Engine Trouble Code Information** to view current DTCs and related repair information.

If SureTrack information is available for a selected DTC, the SureTrack status bar will display **“SureTrack - Results for XXX”** (XXX = the selected DTC).

To view SureTrack information for a specific DTC, select the desired DTC from the list to highlight it, then select the **Fix It!** icon (Figure 4-15). Selecting **Fix It!** opens the SureTrack dashboard. See [SureTrack Dashboard on page 36](#) for additional information.



NOTE:

The Common Replaced Parts graph can be viewed directly from the DTC results screen by selecting the Common Replaced Parts Graph icon, located to the left of Common Replaced Parts Graph title bar (Figure 4-15).

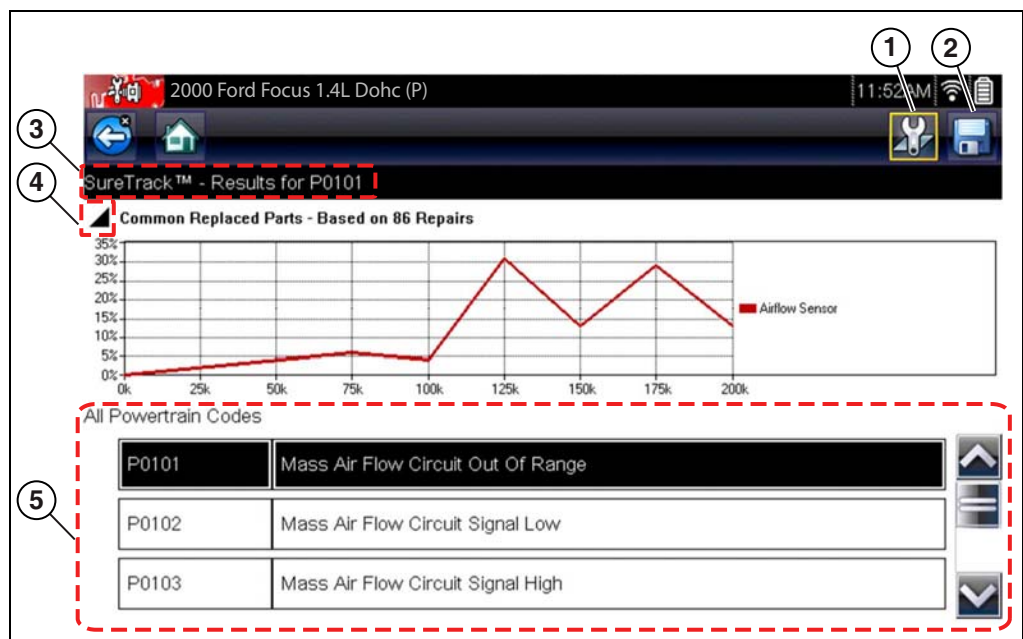
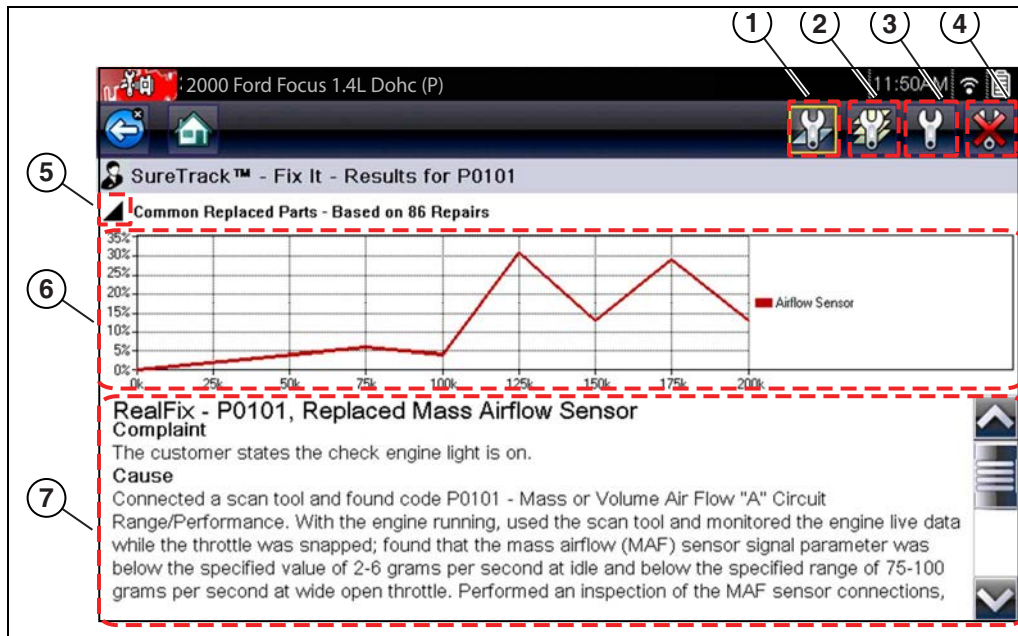

Figure 4-15 SureTrack DTC results

- 1— **Fix It! Icon** — opens SureTrack Dashboard
- 2— **Save Icon** — saves the DTCs list (see, [Saving and Reviewing Scanner / OBD-II/EOBD Data Files on page 29](#))
- 3— **SureTrack Status Bar** — displays the active SureTrack status or result
- 4— **Common Replaced Parts Graph Icon** — toggles graph display open/close
- 5— **DTC Results List** — displays current DTCs

SureTrack Dashboard

Selecting the **Fix It!** icon from the DTC results screen opens the SureTrack dashboard. The initial Dashboard screen displays both the Common Replaced Parts Graph and either a Tip or Real Fix for the current DTC (depending on availability). The Related Tips and Real Fixes icons are also available from this screen (Figure 4-16).



- | | |
|------------------------|------------------------------------|
| 1— Fix It! Icon | 5— Common Replaced Part Graph Icon |
| 2— Related Tips Icon | — toggles graph display open/close |
| 3— Real Fixes Icon | 6— Common Replaced Part Graph |
| 4— Dashboard Exit Icon | 7— Real Fix |

Figure 4-16 SureTrack dashboard

Common Replaced Parts Graph

The Common Replaced Parts graph is displayed by selecting the **Fix It!** icon or can be viewed directly from the DTC results screen by selecting the **Common Replaced Parts Graph** icon, located to the left of Common Replaced Parts Graph title bar. The Common Replaced Parts graph shows the percentage of verified fixes (using the parts listed) derived from the total number of repairs by mileage. The graph may display one or more replacement parts based on the captured information. The example below shows a common replaced part for DTC P0106. In this example, the Airflow Sensor is the most common replaced part based on 86 repairs involving vehicles with up to 200k miles. From the graph it can be determined that the majority of the repairs were made to vehicles with 125k or more miles, with 30% at 125k miles and approximately 28% at 175k miles (Figure 4-17).

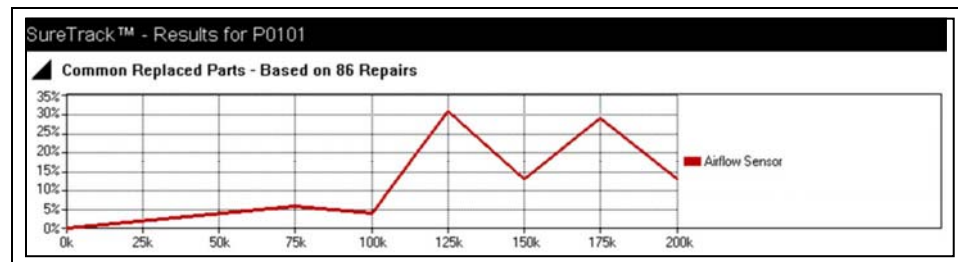

Figure 4-17 Common Replaced Parts graph

Real Fixes and Related Fixes

- **Real Fixes** - Verified successful repair information and/or procedures for the selected DTC
- **Related Real Fixes** - Additional **Real Fixes** that may be related to the selected DTC.

Fixes have been researched and obtained from professional automotive OEM and specialty technicians from a vast range of repair shops. Fixes may not be available for every vehicle and or DTC.

Fixes (if available) can be displayed in two ways:

- Selecting the **Fix It!** icon (Figure 4-16) from the DTC results screen opens the SureTrack dashboard which may include Real Fixes for the selected DTC. If Real Fixes are not available for the DTC, Tips may be displayed.
- Selecting the **Real Fixes** icon (Figure 4-16) displays Related and Real Fixes (if available). Selecting an item from the list opens additional details about the Fix in a Complaint, Cause, Correction format (Figure 4-18 and Figure 4-19).

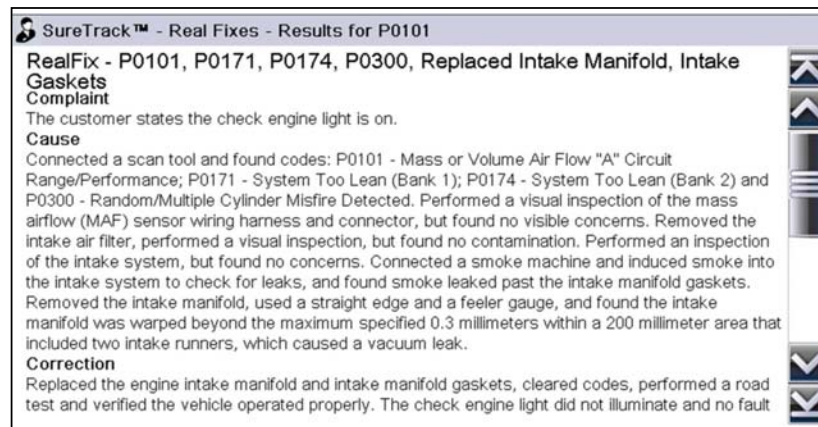

Figure 4-18 Real Fix example



Figure 4-19 Related and Real Fixes examples

Tips and Related Tips

- **Tips** - Experience-based diagnostic and repair tips and information for the selected DTC
- **Related Tips** - Additional **Tips** that may be related to the selected DTC

Tips have been researched and obtained from professional automotive OEM and specialty technicians from a vast range of repair shops. Tips may not be available for every vehicle and or DTC.

Tips (if available) can be displayed in two ways:

- Selecting the **Fix It!** icon from the DTC results screen opens the SureTrack dashboard which may include Tip(s) for the selected DTC. If Tips are not available for the DTC, Real Fixes may be displayed.
- Selecting the **Related Tips** icon will display a list of Related Tips. Selecting an item from the list, opens additional details about the Related Tip (Figure 4-20).

Tip information may include DTC descriptions, symptoms, setting conditions, repair actions and procedures, clearing conditions, diagnostic aids and other references.

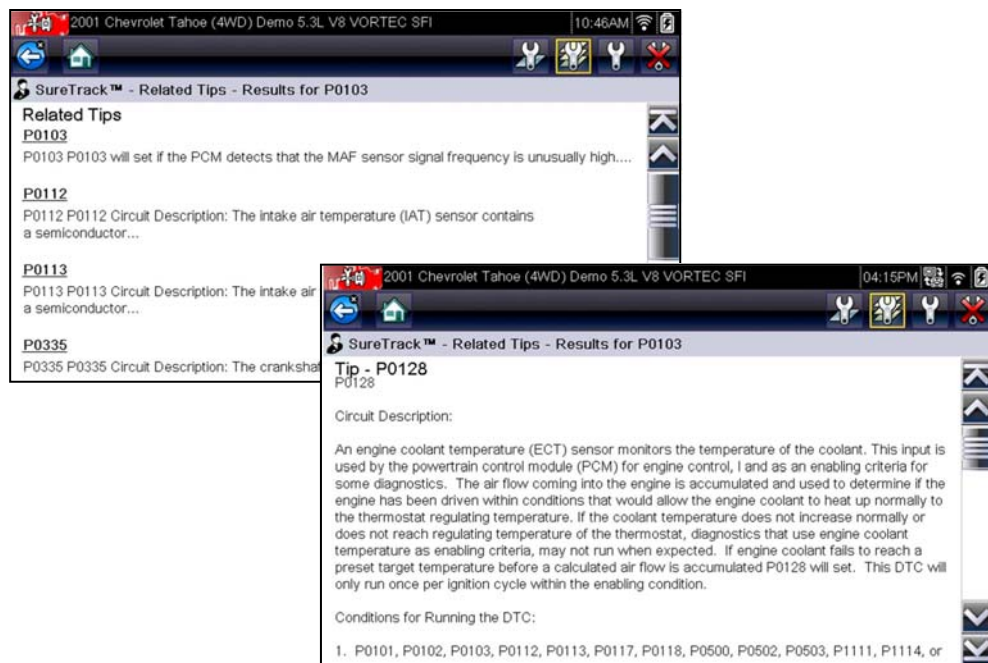

Figure 4-20 Tips and Related Tips examples



Code Scan allows you to quickly scan all supported vehicle control modules for codes. In addition, Global OBD-II codes and Readiness Monitors are scanned giving you a complete health check of vehicle systems.

One of the benefits of performing a code scan is that you can quickly show your customer diagnostic related issues with a pre scan report, and then after repairing the issues you can use the post scan report to show that the repairs were completed (Figure 5-1). In addition, by using ALTUS the reports can be given to the customer and also saved for your own records, for more information, see [Vehicle System Report \(ALTUS™\)](#), on page 46.

IMPORTANT:

PRE / POST Scan Importance - As many systems do not turn on the check engine light or other indicator, performing a vehicle code scan before making any repairs may help in troubleshooting, by identifying possible unknown issues that may be related to the present symptoms.

Performing pre and post scans also allows you to record in report format the pre-condition of the vehicle and compare the post scan after work is complete to confirm the repairs were completed properly.

Pre and post scan is required by some manufacturers for pre and post collision work as well as by some insurance companies.

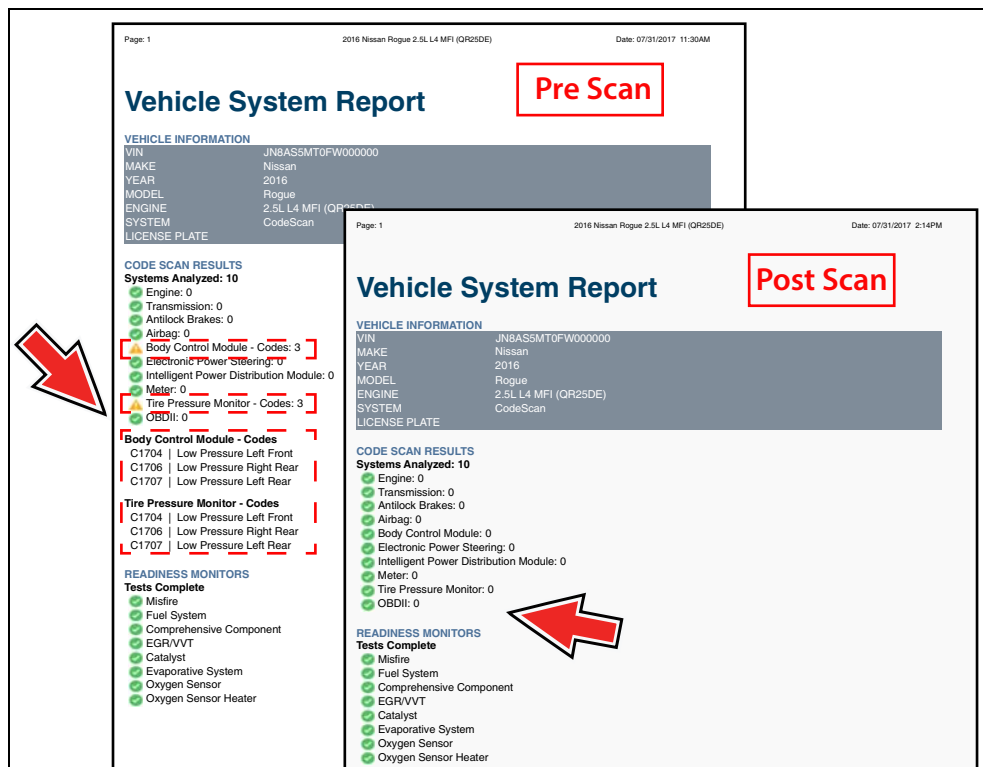

Figure 5-1

5.1 Using Code Scan



NOTE:

The Code Scan function and results are dependent upon the vehicle. Not all vehicles may support this function.

After you have connected and identified a vehicle through Scanner, Code Scan is available from the Vehicle System menu.

Selecting **Code Scan** from the Vehicle System menu (Figure 5-2) starts an active scan of vehicle control modules, and opens the Code Scan results screen (Figure 5-3).

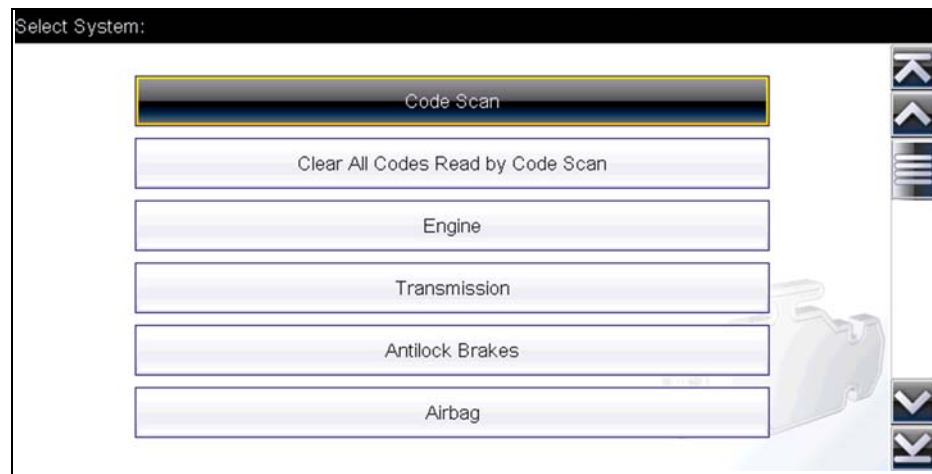

Figure 5-2



NOTE:

Selecting **Clear All Codes Read by Code Scan** (Figure 5-2) erases all DTCs from all vehicle system modules that were read by Code Scan. Selecting this function may not clear global OBD-II codes on some vehicles.

When initially opened (Figure 5-3), a progress bar is shown at the top indicating the active scanning progress. Once completed, code results are displayed by system.

The following results are displayed as the modules are scanned and are described in the following sections.

- [Total Number of Systems \(modules\) Analyzed](#)
- [List of All the Systems Analyzed with DTCs Totals](#)
- [Global OBDII DTCs](#)
- [Readiness Monitor Test Status](#)

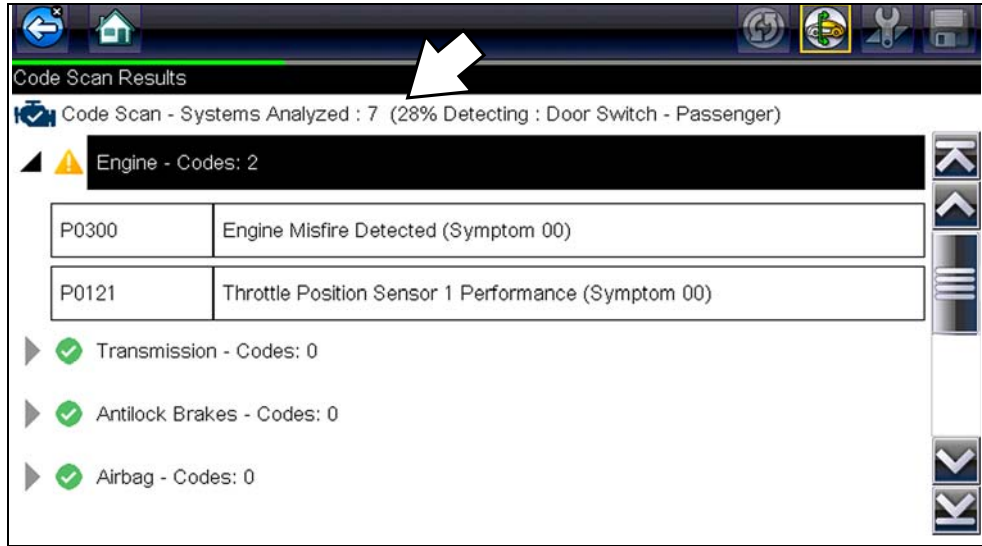





Figure 5-3 Code Scan in process

Code Scan control icons are located on the upper toolbar (Figure 5-3), and provide the following functions.

Icon	Function
	Refresh - Refreshes the code scan data (restarts the code scan)
	System - Opens the main menu of the system selected (highlighted)
	Save - Saves the code scan results as an (.XML) file. See View Saved Data , on page 72.

After the code scan has completed it is automatically saved as an .XML file on the diagnostic tool, and is uploaded to your account on ALTUSDRIVE.com (if registered and connected).

A confirmation message is displayed indicating that the file was saved (e.g. **Message Example:** "Saving A2810005.XML").

To view the report on the diagnostic tool, see [View Saved Data](#), on page 72.

To view/print the report on ALTUS, see [Vehicle System Report \(ALTUS™\)](#), on page 46.



NOTE:

The code scan can also be saved manually by selecting the **Save** icon.

5.1.1 Total Number of Systems (modules) Analyzed

The total number of systems analyzed is actively displayed at the top of the screen as they are scanned.

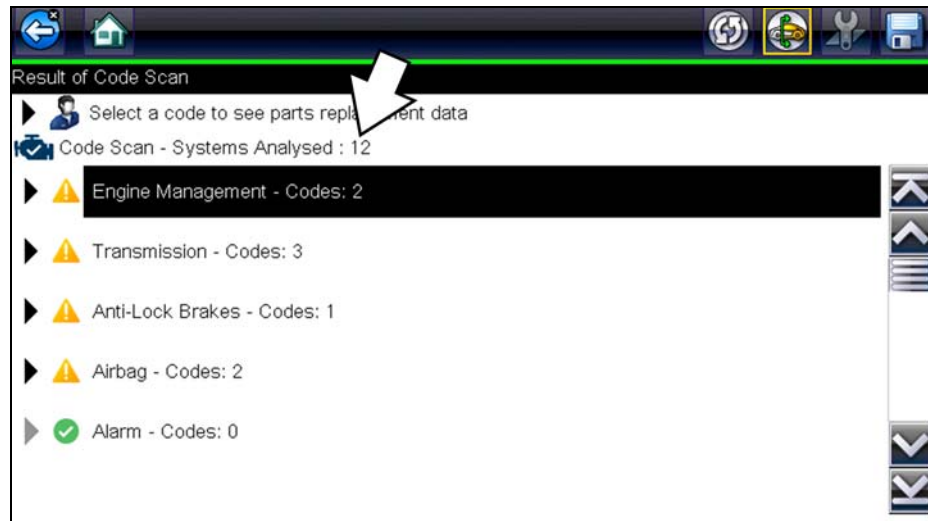

Figure 5-4 Code Scan systems analyzed result total

5.1.2 List of All the Systems Analyzed with DTCs Totals

A categorized system list with DTC totals is displayed in the order they are scanned. To view the main menu for a system in the list, select the system, then select the **System** icon (Figure 5-5).

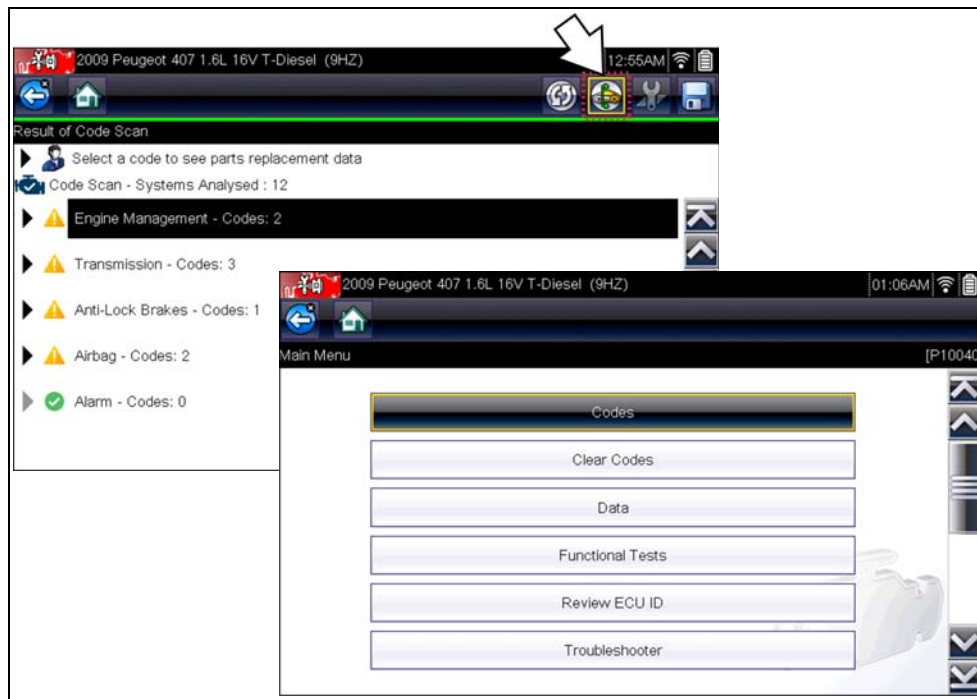

Figure 5-5 System icon (opens Main Menu)

Select the **expand/collapse** icon (Figure 5-6) on the left side of a system category title to expand or collapse a systems' DTC list.

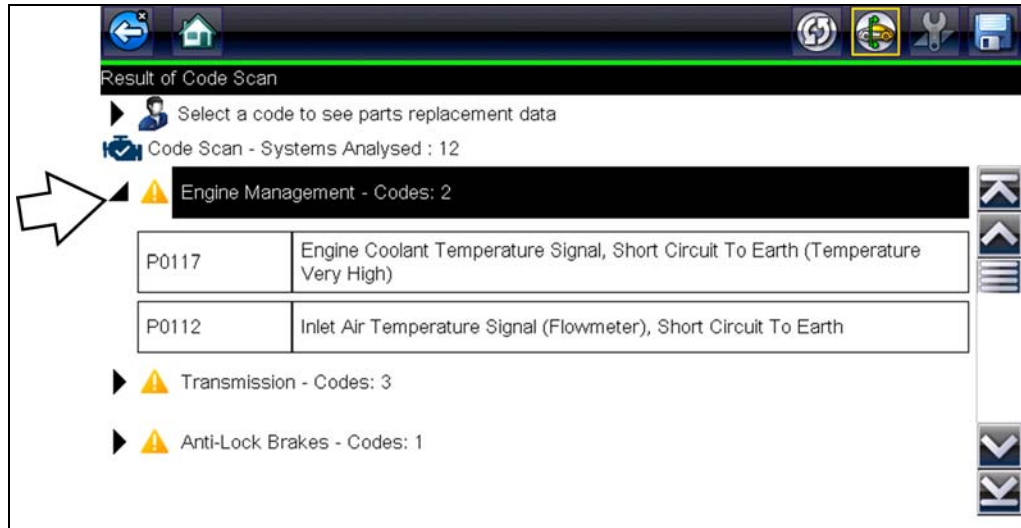

Figure 5-6 Expand/Collapse Icon (expanded result)

5.1.3 SureTrack® Common Replaced Parts Graph

Selecting a DTC allows you to view available SureTrack Common Replaced Parts and repair information for the DTC. Select the **Common Replaced Parts** graph or the **Fix It!** icon from the toolbar for the code information. For additional information on SureTrack, and common replaced parts graph see [SureTrack®](#), on page 40.

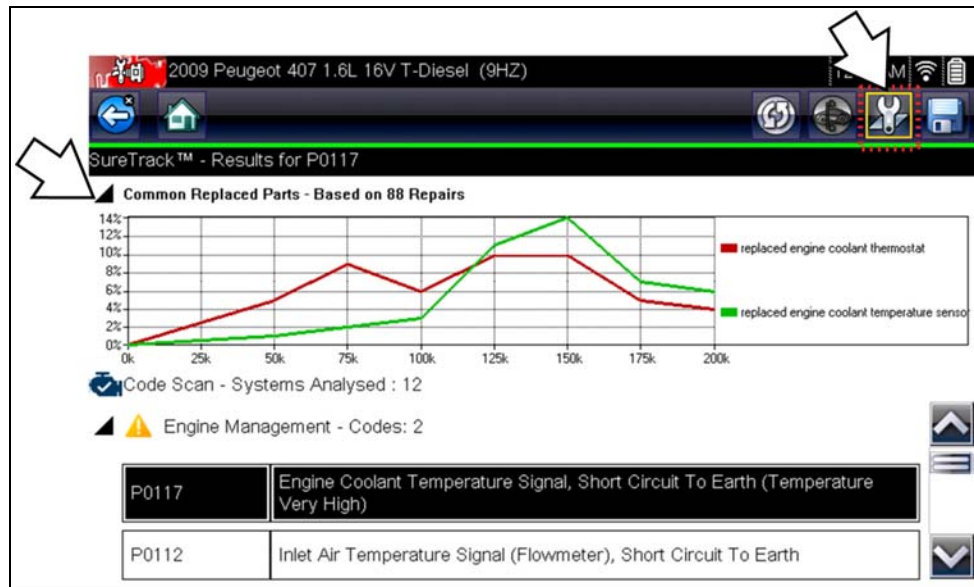

Figure 5-7 Common Replaced Parts graph icon and Fix It! icon (in toolbar)

5.1.4 Global OBDII DTCs

Towards the end of the Code Scan list Global OBDII DTCs are displayed.

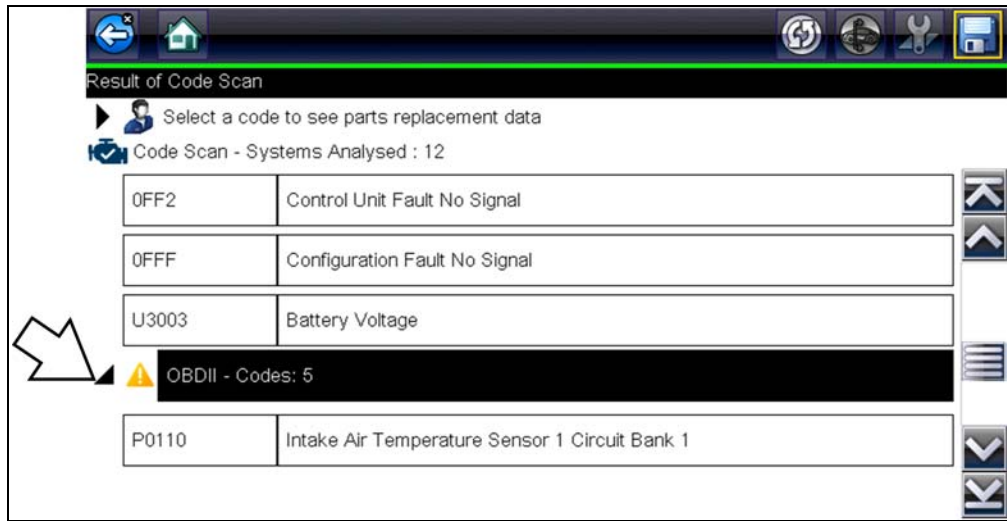



Figure 5-8

NOTE:  Some 2005 to 2008 vehicles may not display global OBD-II information in the Code Scan list. A message will be displayed to inform you the OBD-II - codes and monitors for this vehicle may be accessed using the global OBD-II function. See [OBD-II/EOBD](#), on page 47.

5.1.5 Readiness Monitor Test Status

At the end of the Code Scan list, readiness monitor test results are displayed as “Tests Complete” or “Not Complete”.

Quick reference indicators are used to show monitor status.

Green icon “✓” mark - Monitor test is complete

- **Grey icon “—” mark** - Monitor test is not complete

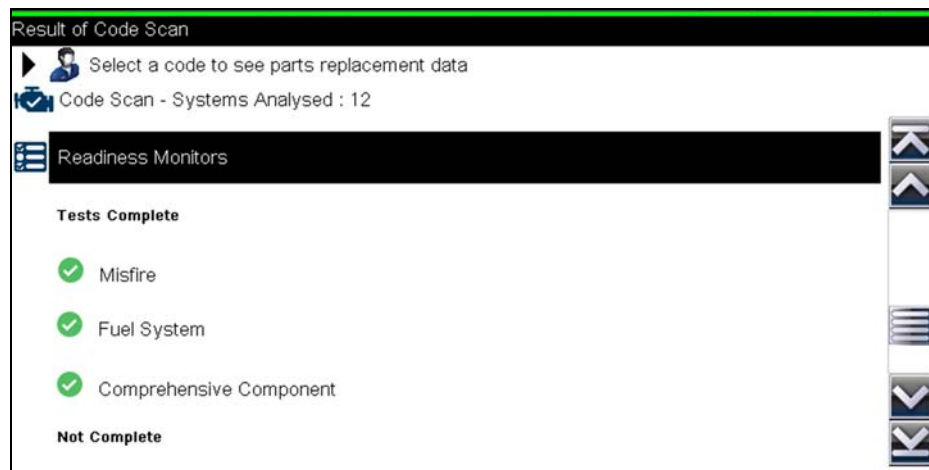

Figure 5-9

**NOTE:**

Monitors that are not supported by the vehicle are not displayed in Code Scan.

5.2 Vehicle System Report (ALTUS™)

After a code scan is completed the results of the scan are automatically configured into a Vehicle System Report that is uploaded and saved to your ALTUS online account (if registered and connected). Report examples are shown in [Figure 5-1](#).

Using ALTUS the report can be printed, downloaded, attached to an e-mail or other social media app to share with others. For additional information on using ALTUS, see [ALTUS \(ALTUSDRIVE.com\) - Cloud Sharing/Storage](#), on page 140.

**NOTE:**

Code scan reports are automatically saved each time a code scan is performed. If using ALTUS, the report is automatically uploaded to your online ALTUS account on ALTUSDRIVE.com.

The code scan/vehicle system report includes:

- Basic vehicle information
- A list of the code scan results by system
- Individual system DTCs with a brief description
- Global OBD codes
- Readiness monitor test status

5.2.1 Printing the Vehicle System Report

Use ALTUS to print the vehicle system report from your PC or mobile device, see [Quick Reference \(print / download / share\)](#), on page 143.

The vehicle system report can also be customized and printed using ShopStream Connect - See [Printing the \(Code Scan\) Vehicle System Report](#), on page 168.

This chapter describes the basic operation of the OBD-II/EOBD function.



The **OBD-II/EOBD** icon is located on the Home screen.

The OBD-II/EOBD function allows you to access “generic” OBD-II/EOBD data. Generic OBD-II/EOBD data is data limited to emission related diagnostics such as:

- Checking for emissions-related diagnostic trouble codes (DTCs)
- Checking the cause of an illuminated malfunction indicator lamp (MIL)
- Checking monitor status prior to emissions certification testing

To access other available electronic control module (ECM) data for vehicle specific systems, parameters or enhanced diagnostics use the Scanner function, see [Scanner on page 16](#).



NOTE:

The OBD-II/EOBD function can also be used to access “generic” OBD-II/EOBD data for OBD-II/EOBD compliant vehicles that are not included in the Scanner function databases.

6.1 Basic Operations

6.1.1 Screen Layout and Toolbar Controls

Screen layout and toolbar controls are similar to the Scanner function, see [Scanner Control Icons on page 17](#).

6.1.2 Connecting the Data Cable

Connection of the data cable to the Diagnostic Tool and vehicle DLC is required for OBD-II/EOBD testing, see [Data Cable Connection](#), on page 14.

6.1.3 Saving and Reviewing Data Files

Save and Pause control icon operation and data review procedures are the same as used for the Scanner function, see [Saving and Reviewing Scanner / OBD-II/EOBD Data Files](#), on page 29.

6.2 OBD-II/EOBD Menu

The following options are available from the OBD-II/EOBD menu:

- [OBD Health Check](#)
- [OBD Direct](#)

6.2.1 OBD Health Check

The OBD-II Health Check offers a way to quickly check for and clear emissions-related diagnostic trouble codes (DTCs), and to check readiness monitors for emissions testing. Selecting opens a connection message. Select **Continue** or press the **Y/✓** button to open a submenu of test options (Figure 6-1).



Figure 6-1 OBD Health Check menu

Global OBD II Code Check

Global OBDII Code Check displays stored emission related generic DTCs reported by the ECM. Selecting opens a submenu with two choices: Codes and Pending Codes. Either option opens a code list (Figure 6-2).

The DTC results screen is similar to the same screen used in the Scanner function, as both display the SureTrack results message below the toolbar. However, SureTrack is not accessible and no information is displayed in OBD-II/EOBD mode. SureTrack is only accessible in the Scanner function where the vehicle has been identified.

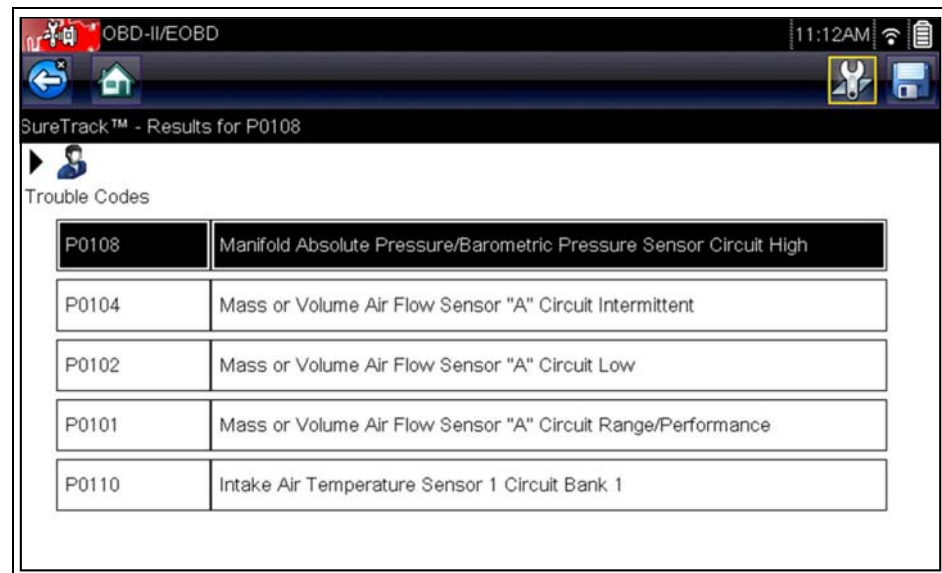

Figure 6-2 DTC Results Screen

Codes

The Codes option displays a list of current emission related DTCs.

OBD-II/EOBD Codes have a priority according to their emission severity. The priority of the code determines the illumination of the MIL and the code erase procedure. Vehicle manufacturers have implemented the ranking differently, so there are differences between makes.

Pending Codes

The purpose of this service is to enable the Diagnostic Tool to obtain “pending” or maturing diagnostic trouble codes. These are codes whose setting conditions were met during the last drive cycle, but need to be met on two or more consecutive drive cycles before the DTC actually sets.



NOTE:

Save valuable time by using this service to verify test results after a single drive cycle following a vehicle repair and code clearing procedure.

- If a test failed during the drive cycle, the DTC associated with that test is reported. If the pending fault does not occur again within 40 to 80 warm-up cycles, the fault is automatically cleared from memory.
- Test results reported by this service do not necessarily indicate a faulty component or system. If test results indicate another failure after additional driving, then a DTC is set to indicate a faulty component or system, and the MIL is illuminated.

Refer to the *Global OBD Vehicle Communication Software Manual* for additional information.

Global OBD II Clear Codes

This option is used to clear all emission related diagnostic data, such as DTCs, freeze frame data, and test results, from the memory of the selected ECM. Although OBD-II/EOBD displays generic OBD-II/EOBD data only, clearing codes erases all of the stored data, including any enhanced codes and freeze frame information.

A confirmation screen displays when the clear codes option is selected to prevent accidental loss of data. Select to continue from the confirmation screen. Refer to the *Global OBD Vehicle Communication Software Manual* for additional information.

Readiness Monitors

This test checks the status of the readiness monitoring system. An OBD-II /EOBD control system runs continuous and periodic tests to check the status of emission-related systems. Two options are available for Readiness Monitors:

- **Monitors Complete Since DTC Cleared**—displays the status of all monitors that have run since the last time ECM memory was erased.
- **Monitors Complete This Cycle**—displays the status of the monitors that ran during the current drive cycle only.

Selection of either option displays test results as shown in the data viewer (Figure 6-3).

Quick reference indicators are used to show monitor status on the left side of the screen (Figure 6-3):

- **Green icon “✓” mark** - Monitor test is complete
- **Grey icon “—” mark** - Monitor test is not complete
- **Red icon “X” mark** - Monitor test is not supported by vehicle

ID : \$		1439 / 4000
ID : \$		E8
✓	MISFIRE	TEST COMPLETE
✓	FUEL SYSTEM	TEST COMPLETE
✓	COMPONENTS	TEST COMPLETE
—	CATALYST	NOT COMPLETE
✗	HEATED CATALYST	NOT SUPPORTED
—	EVAPORATIVE SYSTEM	NOT COMPLETE
✗	SEC. AIR SYSTEM	NOT SUPPORTED

Figure 6-3 Readiness monitor test report

Use the scroll bar to view the entire list of Readiness Monitors.

Selecting **Save** from the toolbar saves the monitor data as an .SCM file for review at a later time. See [View Saved Data](#), on page 72 for additional information.

MIL Status

This test checks the ECM commanded state (on or off) if the malfunction indicator lamp.

6.2.2 OBD Direct

OBD Direct includes the following menu and submenu choices:

- **OBD Diagnose**
 - **Start Communication** - initiates a test session
 - **Connector Information** - provides DLC location details
 - **Manual Protocol Selection** - provides choices for communication protocol
- **OBD Training Mode** - allows you to familiarize yourself with the capabilities of OBD-II/EOBD while navigating through menus without being connected to a vehicle.

Start Communication

Use the following procedure to begin an OBD-II/EOBD test session:



To perform an OBD-II/EOBD Test:

1. Connect the data cable to the test vehicle.
2. Select **Start Communications** from the OBD-II/EOBD menu.

A series of messages are displayed indicating automatic detection of vehicle type (12 or 24 V) has occurred and then the detected controllers are displayed.

The Diagnostic Tool establishes a communication link with the test vehicle, then opens an information screen (Figure 6-4).

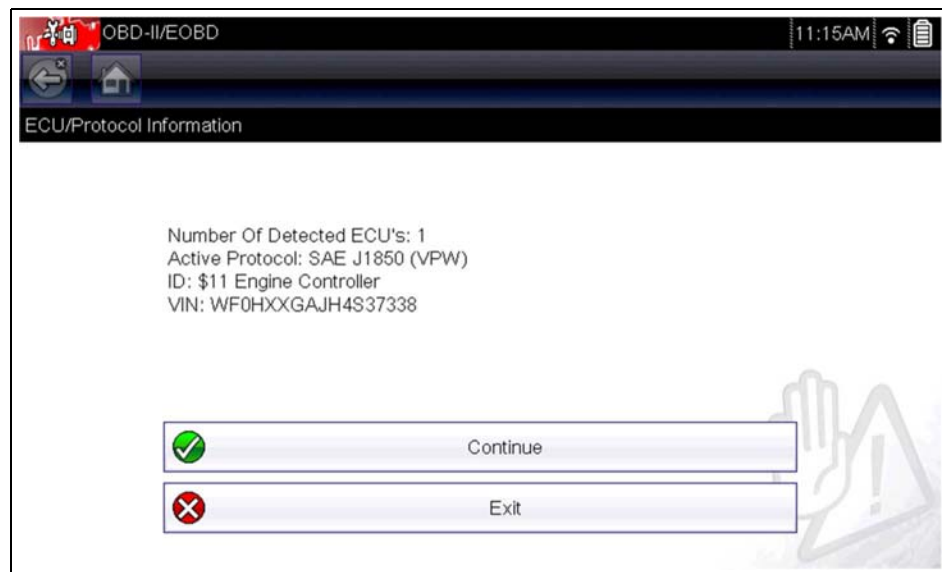

Figure 6-4 Protocol information

The information screen shows how many control modules were detected, which ECM is communicating, and which communication protocol is being used.

3. Select **Continue**.

A Select Service menu of available tests opens:

- [Readiness Monitors](#), on page 52
- [MIL Status](#), on page 52
- [Fast-Track Troubleshooter](#), on page 52
- [\(\\$01\) Display Current Data](#), on page 53
- [\(\\$02\) Display Freeze Frame Data](#), on page 53
- [\(\\$03\) Display Trouble Codes](#), on page 53
- [\(\\$04\) Clear Emissions Related Data](#), on page 53
- [\(\\$05, 06, 07\) Display Test param./Results](#), on page 54
- [\(\\$08\) Request Control of On-board System](#), on page 55
- [\(\\$09\) Read Vehicle Identification](#), on page 55
- [\(\\$09\) In-use Performance Tracking](#), on page 55
- [\(\\$0A\) Emission Related DTC with Permanent Status](#), on page 55

IMPORTANT:

All service modes are not supported by all vehicles, so the available menu selections will vary.

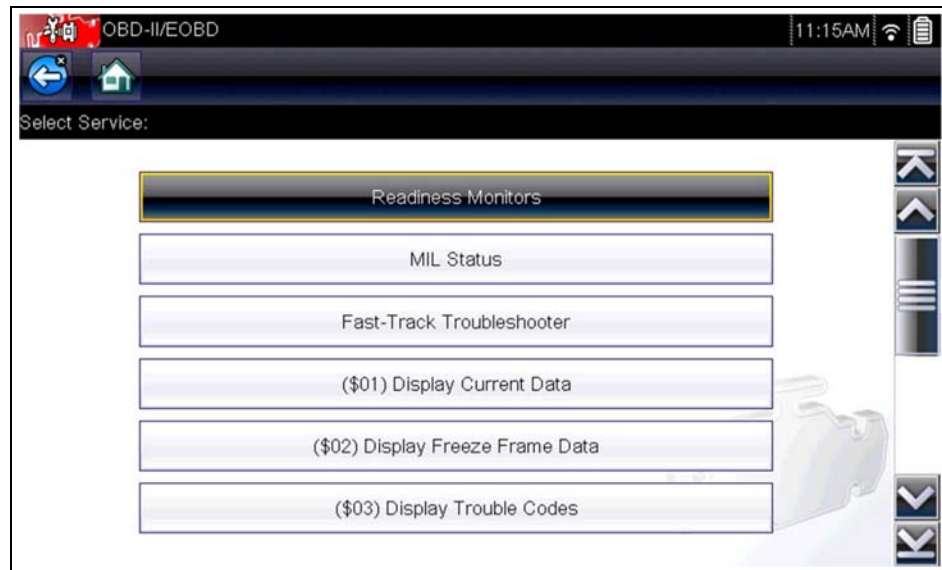

Figure 6-5 Service mode menu

4. Select a test to continue.

Readiness Monitors

Use this menu item to check the readiness of the monitoring system. Monitors not supported will display “not supported”. Scroll, if needed, to view the entire list of monitors (Figure 6-3). Selecting Readiness Monitors opens a submenu with two choices:

- **Monitors Complete Since DTC Cleared**—displays the results of all monitor tests that have run since the last time the vehicle electronic control module (ECM) memory was cleared.
- **Monitors Complete This Cycle**—displays only the results of monitor tests that ran during the current drive cycle, they reset when the ignition is switched off.

MIL Status

This item is used to check the current condition of the malfunction indicator lamp (MIL). Additional information, such as which ECM commanded the MIL on and the distance driven while the MIL is on (if supported), can also be displayed. The MIL Status report can also be saved as part of the vehicle records.

Fast-Track Troubleshooter

Fast-Track[®] Troubleshooter is a database of experience-based repair strategies and information, that has been compiled and validated by top-notch technicians. The Troubleshooter system simplifies the diagnosis process, as it contains information on virtually all common diagnostic trouble code (DTC) problems and driveability symptoms for most vehicles covered by the vehicle communication software.

(\$01) Display Current Data

Use this test to display the serial data transmitted by the selected vehicle electronic control module (ECM). The main body of the screen has two columns; the left-hand column is a description of the parameter and the right-hand column is the parameter value or state. Viewing options and operations are the same as the Scanner function, see [Data Display](#), on page 24 for more information.

Parameter	Value
ID : \$	11
ENGINE SPEED(1/min)	4128
ABSOLUTE THROTTLE POSITION(%)	50.2
INTAKE AIR TEMPERATURE (°F)	190
ENGINE COOLANT TEMPERATURE (°F)	219
AIR FLOW RATE(g/s)	11.52
INTAKE MAP (inHg)	59.6

Figure 6-6 Current data display

(\$02) Display Freeze Frame Data

Freeze frame data provides a “snapshot” of critical parameter values at the time a DTC set.

This item is used to display freeze frame data for any stored emission related diagnostic trouble codes (DTCs). In most cases the stored frame is the last DTC that occurred. Certain DTCs, those that have a greater impact on vehicle emissions, have a higher priority. In these cases, the highest priority DTC is the one for which the freeze frame records are retained.

(\$03) Display Trouble Codes

This is used to display any stored emission related DTCs reported by the ECM. The display is similar to the Scanner function code display (see [Display Codes](#), on page 22 for details). The list does not include enhanced DTCs in this mode.

(\$04) Clear Emissions Related Data

This item is used to clear all emission related diagnostic data, such as DTCs, freeze frame data, and test results, from the memory of the selected ECM.



To clear emission related Data:

1. Select **Clear Emissions Related Data** from the menu.

A confirmation message displays to help prevent loss of any vital data (Figure 6-7).

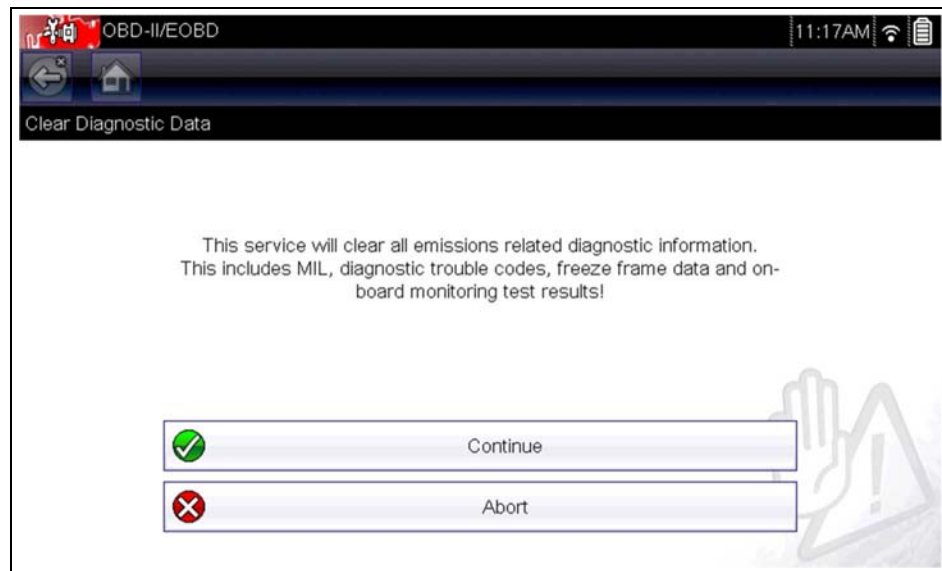

Figure 6-7 Clear codes confirmation message

2. Continue from the confirmation message.

The screen updates several times as ECM memory is erased, then a “data has been cleared” message displays.

3. Select **Continue** to return to the Select Service menu.

(\$05, 06, 07) Display Test param./Results

This option opens a submenu of parameters and test results from various sensors, monitor test results, and a record of DTC setting conditions detected during the last drive cycle. The submenu includes:

- [\(\\$05\) Oxygen Sensor Monitoring](#)
- [\(\\$06\) On-board Monitored Systems](#)
- [\(\\$07\) DTCs Detected During Last Drive](#)

(\$05) Oxygen Sensor Monitoring

This option opens a menu of tests available for checking the integrity of the oxygen (O₂) sensors. Making a selection displays all of the pertinent O₂ sensor parameters for the specific test. The test identification (ID) displays at the top of the data list.

(\$06) On-board Monitored Systems

This option opens a menu of tests from the monitored systems. The available data is for specific systems and components that the on-board diagnostic system monitors continuously, such as misfire, or non-continuously, such as the catalyst system. Making a menu selection displays the test results.

(\$07) DTCs Detected During Last Drive

This test opens a record of any DTCs that set during the last completed drive cycle. Select to open the DTC list.

(\$08) Request Control of On-board System

This service enables bidirectional control of the ECM. This service allows the Diagnostic Tool to control the operation of an on-board system, test, or component.

(\$09) Read Vehicle Identification

The purpose of this service is to enable the Diagnostic Tool to request and display vehicle-specific information, such as the vehicle identification number (VIN), the calibration identification, and the calibration verification number (CVN), of the test vehicle. Select a menu item to retrieve the information. Select **Return** to go back to the menu.

(\$09) In-use Performance Tracking

This option displays the “In-use Performance Tracking” of data. It is a record of the number of times each of the monitor tests have been completed. Select **Return** to go back to the menu.

(\$0A) Emission Related DTC with Permanent Status

This option displays a record of any “permanent” codes. A permanent status DTC is one that was severe enough to illuminate the MIL at some point, but the MIL may not be on at the present time.

Whether the MIL was switched off by clearing codes or because the setting conditions did not repeat after a specified number of drive cycles, a record of the DTC is retained by the ECM. Permanent status codes automatically clear after repairs have been made and the related system monitor runs successfully.

Connector Information

This option opens a database of vehicle diagnostic connector locations that includes most makes and models. The menu driven interface leads you quickly to difficult to find test connectors.



To locate a vehicle diagnostic connector:

1. Select **Connector Information** from the System menu.
A list of vehicle manufacturers displays.
2. Select a manufacturer from the list.
A list of models available from the selected manufacturer displays.
3. Select a model from the list.
If a cable adapter is needed, which one and how to connect it displays.
4. Select **Continue**.
Information on where to locate the vehicle diagnostic connector displays.
5. Select **Continue** to return to the System menu.

Manual Protocol Selection

Communication protocol is a standardized way of transferring data between an ECM and a Diagnostic Tool. Global OBD may use the following communication protocols:

- ISO 15765-4 (CAN)
- ISO 27145 (WWHOBD CAN)
- ISO J1939 (CAN)
- ISO 9141-2 (K-LINE)
- SAE J1850 PWM (Pulse Width Modulation)
- SAE J1850 VPW (Variable Pulse Width)
- ISO 14230-4 (Keyword Protocol 2000)
- SAE J2284/ISO 15765-4 (CAN)

When initially attempting to establish communication with the ECM the Diagnostic Tool attempts to communicate trying each protocol in order to determine which one is being used. During normal operation the communication protocol is automatically detected. If automatic detection fails, communication protocol can be manually selected.

IMPORTANT:

Using unsupported OBD communication protocols may activate warning lights and can set network related faults. Only use the manual selection option when OBD protocol is already known.

Select **Manual Protocol Selection** to open a menu of options (Figure 6-8).



Figure 6-8 Manual protocol selection menu

Select the **Back** icon or press the **N/X** button to return to the OBD-II/EOBD Main menu.

This chapter describes the basic operation, and navigation of the TSBs (Technical Service Bulletins) function.

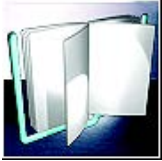

The **TSBs** icon is located on the Home screen.

The TSBs function can provide the following Original Equipment Manufacturer (OEM) Technical Service Bulletin information (if available) for the identified vehicle:

- Symptoms
- Causes or Defects*
- Solutions*
- Repair Times
- Parts Required

* Illustrations provided if available.

NOTES:

- To use the TSB feature you **MUST** have the current software upgrade installed on your diagnostic tool, and be connected to a wireless network with Internet access.
 - If you experience a wireless network connection loss, TSB data will not refresh and/or may cause the program to stop. To continue use, you must re-establish your Internet connection.
-

7.1 Operation



NOTE:

The information and procedures provided by the TSBs function is vehicle specific, therefore a vehicle must be identified before information can be displayed.

There are two methods to access this function:

- **Selecting the TSBs icon from the Home screen** - See [Viewing TSBs \(using the Home Screen icon\)](#), on page 58.
- **Selecting the TSBs menu option from within a current Scanner session** - See [Viewing TSBs \(using Scanner\)](#), on page 60.



Viewing TSBs (using the Home Screen icon)

1. Select the **TSBs** icon from the Home Screen (Figure 7-1).

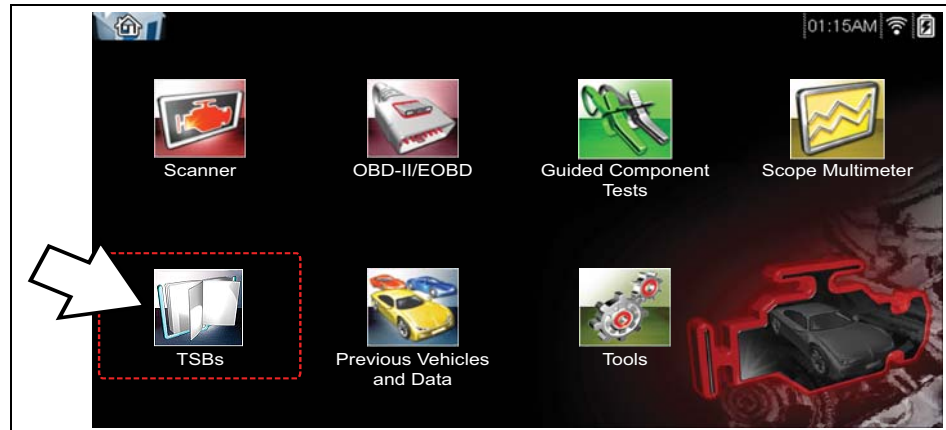

Figure 7-1 Home Screen - TSBs icon

2. Identify the vehicle, by following the screen prompts to select the vehicle information (e.g. **make, year, model**, etc.).
3. Select **OK**.
4. Select a vehicle area, (e.g. **Engine, Transmission, Brakes**, etc) (Figure 7-2).



Figure 7-2 Vehicle Area Menu

5. Select the desired TSB.
If applicable, use the scroll bar or directional buttons (▲, ▼) to scroll up/down to view all of the information.

The example shown in Figure 7-3 shows a typical TSB, describing the symptom, cause, solution, repair time, parts required, and shows an illustration of the applicable part location.

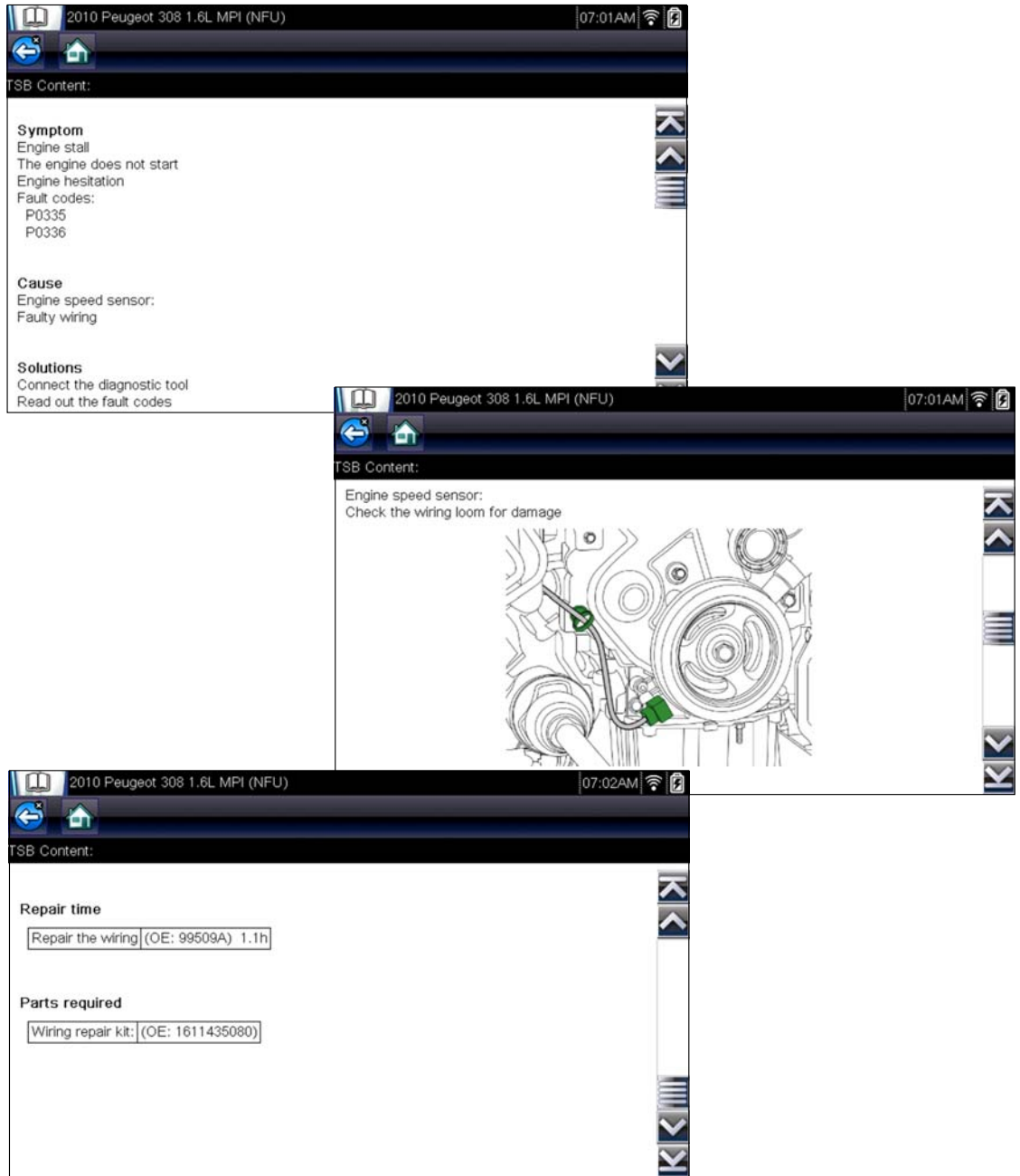

Figure 7-3 Typical - TSB



Viewing TSBs (using Scanner)

1. From within a current Scanner session select **TSBs** from the System menu (Figure 7-4).

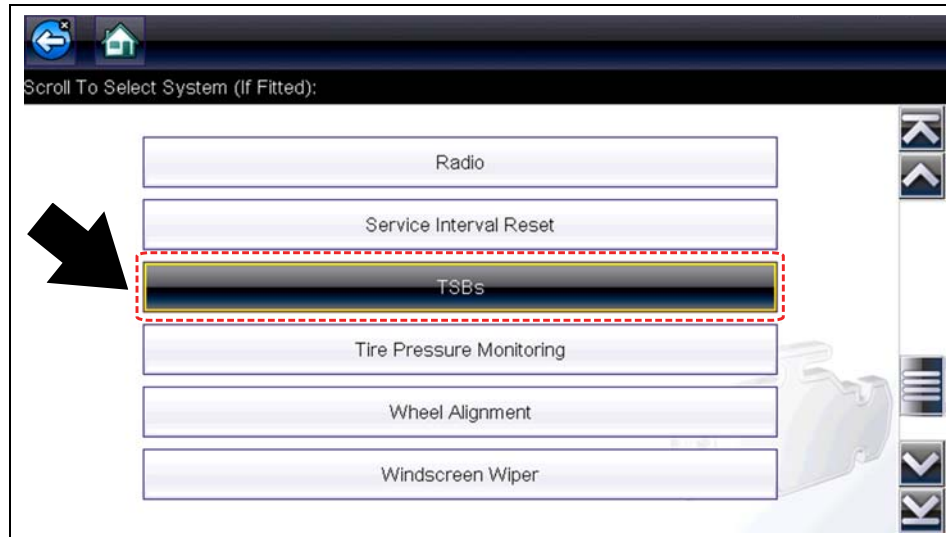

Figure 7-4 Scanner System Menu - TSBs Option

2. Select a vehicle area, (e.g. **Engine, Transmission, Brakes**, etc) (Figure 7-5).



Figure 7-5 Vehicle Area Menu

3. Select the desired TSB.
If applicable, use the scroll bar or directional buttons (▲, ▼) to scroll up/down to view all of the information.
See TSB example in Figure 7-3. The example, illustrates the typical sections of a TSB, the symptom, cause, solution, repair time, parts required, and shows an illustration of the applicable part location.

The Guided Component Tests function provides you with an extensive collection of vehicle specific component tests and reference information. It is like having access to a complete library of automotive repair manuals for testing multiple vehicle components.



The preconfigured meter tests and reference information provided are vehicle specific and designed to help save you diagnostic time, verify faulty components, and verify the repair.

Detailed instructions and reference information are provided to guide you through the testing process, from locating the component, to selecting the appropriate test, showing test lead connections, and illustrating electrical connector and pin configurations. In addition, test results (including waveform examples), procedures, tips, and specifications may also be provided.



NOTE:

Availability of tests and information may vary.

As an added resource, Training and Classes provides even more support by including (non-vehicle specific) tests and resources that allow you to quickly perform common tests, review basic reference information and more.

8.1 Training and Classes

Training and Classes is a companion feature to the Guided Component Tests function. This resource includes a wide collection of common (non-vehicle specific) reference information and tests, such as measuring fuel pump current ramp, and monitoring CKP and CMP signals simultaneously. Also included are, basic component operation and theory information, testing procedures, tips, definitions, illustrations, diagnostic tool feature descriptions and accessory information.

**To access Training and Classes:**

1. Select **Guided Component Tests** from the Home screen.
2. Select **Training and Classes** from the Vehicle Make menu ([Figure 8-1](#)) to access the menu options.

Each menu option is described in the following sections:

All features and information are subject to change. The following is for reference only.

- [Power User Tests](#)
- [How To Guide](#)
- [Features and Benefits](#)
- [Index](#)

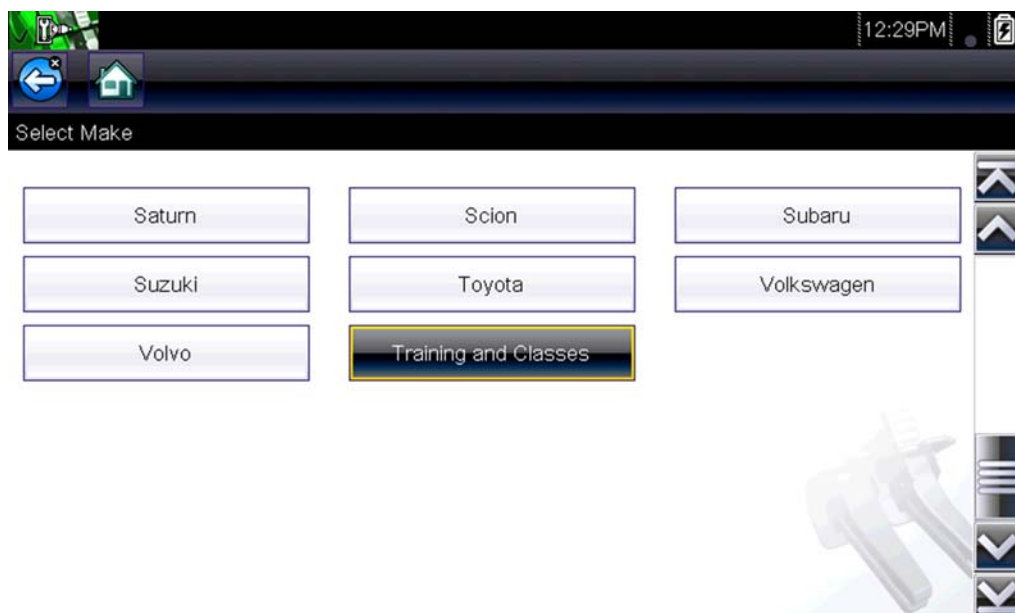

Figure 8-1

8.1.1 Power User Tests

The **Power User Tests** option gives you quick access to a pre-configured meter for conducting a number of control system tests. Tests are available with or without on-screen help. Help typically provides a description of the test along with expected results and a link to the pre-set meter.

8.1.2 How To Guide

The **How To** option provides a list of available on-screen instructions for performing tasks. Scroll to view the entire list. Topics include:

- **10-MINUTE ELECTRONIC CLASS**—provides basic electronics and circuit instructions.
- **15-MINUTE IGNITION CLASS**—provides an introduction to basic ignition testing.
- **ILLUSTRATED TERMS & DEFINITIONS**—provides definitions of terms, drawings and tips associated with component testing.
- **NO-START BASICS**—provides a guideline for diagnosing a no-start condition.
- **O2 SENSOR & FEEDBACK SYSTEM ANALYSIS**—displays a “live” graphing component test meter with tips explaining the fundamental concepts of O2 sensor diagnostics.
- **TEST TIPS**—gives instructions for performing specific tests along with drawings and tips.
- **20-MINUTE CURRENT RAMP CLASSES**—provides an introduction to current ramp testing.

8.1.3 Features and Benefits

Selecting **Features and Benefits** opens a menu page that includes:

- **5-MINUTE WALK THRU WITH DEMO BOARD**—explains how to use the optional demonstration board to generate sample signals and sharpen your skills.

- **Accessories**—opens a menu of available optional equipment.
- **Product description**—provides descriptions and a brief overview of meter operations.

The optional demonstration board transmits a number of adjustable electronic signals similar to what is commonly found on modern vehicles. The demonstration board not only helps you learn how to use the Guided Component Tests software, it allows you to hone your skills and diagnostic techniques without an actual test vehicle. Contact your sales representative for details.

8.1.4 Index

This feature allows you to access detailed service information and specifications for a specific component.

Selecting **Index** opens an alphabetical list of components, systems, tests, terms, and other items for which there is a brief help file. Some items open an additional menu. Use the **Back** and **Exit** buttons on the Toolbar to return or close the screen.

8.2 Screen Layout and Icons

This section describes the Guided Component Tests control icon functions and screen layout.

8.2.1 Screen Layout

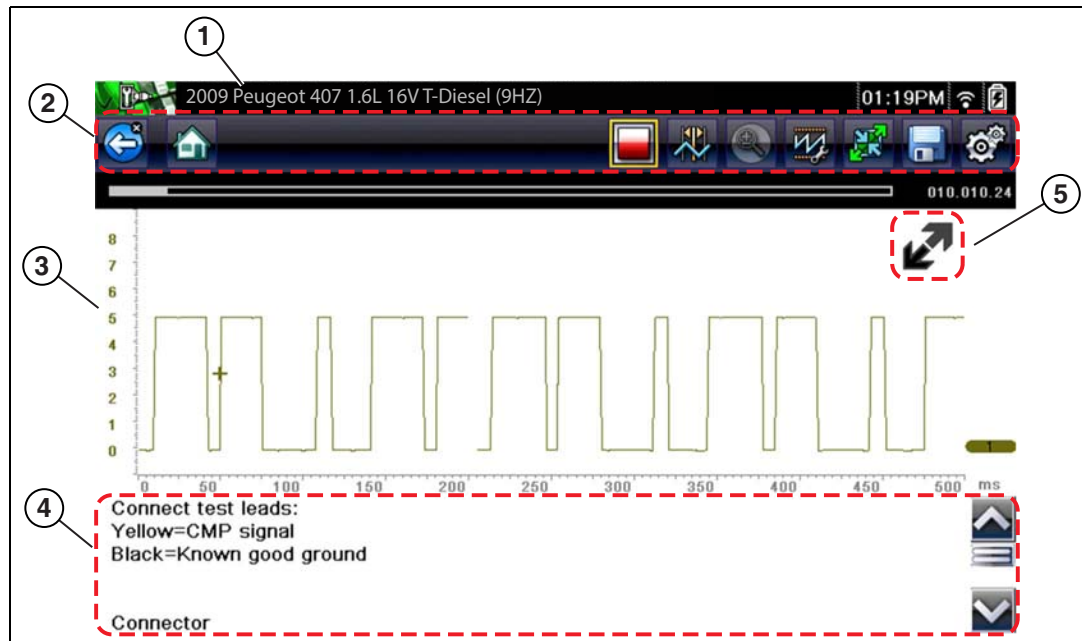

- 1— **Vehicle Identification**
- 2— **Toolbar**—contains control icons
- 3— **Main Body**—displays menus, information, meter scales and signal traces
- 4— **Information Panel**—displays test information
- 5— **Expand/Collapse icon**—toggles Main body view between full and split views

Figure 8-2 Test screen

Main Body

The main body of a Guided Component Test screen may display any of the following:





- **Selectable Menu** - Select menu options using the touch screen or control buttons.
- **Component Information** - Provides information to assist you with testing.
- **Test Meter** - The test meter can display up to two signals, simultaneously. Signal and display adjustments are made through the Control Panel. Signals are displayed using a grid with scales, both vertical (y axis), and horizontal (x axis).

Meter touch screen functionality is limited, however you can adjust the zero baseline position (0 value) of the signal on the horizontal scale by touching and dragging the zero baseline marker.

8.2.2 Guided Component Tests Control Icons

Guided Component Tests toolbar control icons may vary depending on the active function or test. A yellow frame surrounding an icon (highlighted), indicates it is selected. Other control icons (not shown) are described in [Common Toolbar Control Icons](#), on page 12.

Table 8-1

Icon	Function
	<p>Stop - Stops the data buffer.</p>
	<p>Control Panel - (a). In full screen mode (when selected) this icon displays a white frame around it, and opens the control panel at the bottom of the screen; while switching the active selection focus to the Show/Hide or Probe icon in the Control Panel.</p> <p>(b). In split screen mode (control panel open), when selected this icon displays a white frame around it, and switches the active selection focus to the Show/Hide or Probe icon in the Control Panel.</p> <p>Note: Switching active selection focus to the Control Panel allows manual navigation (using the directional control buttons) of the Control Panel control icons.</p>
	<p>Cursors - Toggles cursors on/off.</p>
	<p>Expand/Collapse Icon - Toggles the Main body display between full and split screen.</p>

8.3 Operation

As the information and tests provided within the Guided Component Test function is vehicle specific, the vehicle must first be identified in order to retrieve the correct data.



To identify a vehicle:

The vehicle identification process is the same as the process used for the Scanner function, see [Vehicle Identification](#), on page 18 for additional information. Once the vehicle is identified, a list of Systems is displayed.



To select a system and component to test:

1. Select a system from the list ([Figure 8-3](#)).

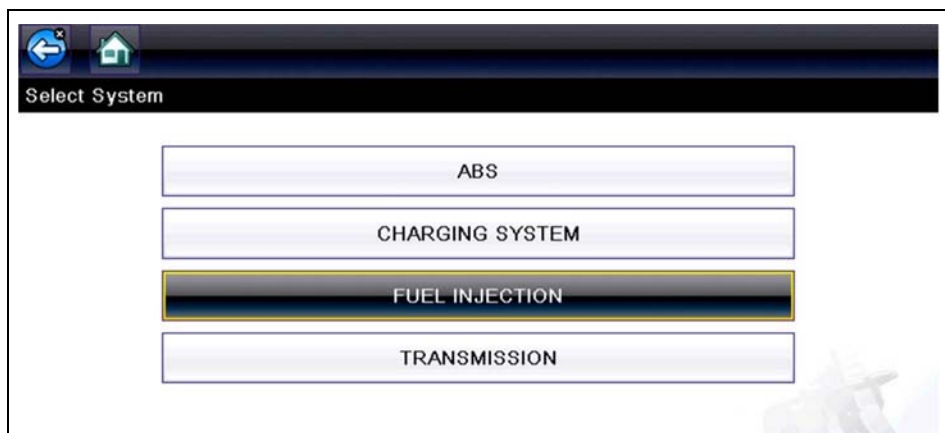

Figure 8-3 Systems Menu

A list of components (and/or sub systems) is displayed ([Figure 8-4](#)).

2. Select a component to test.

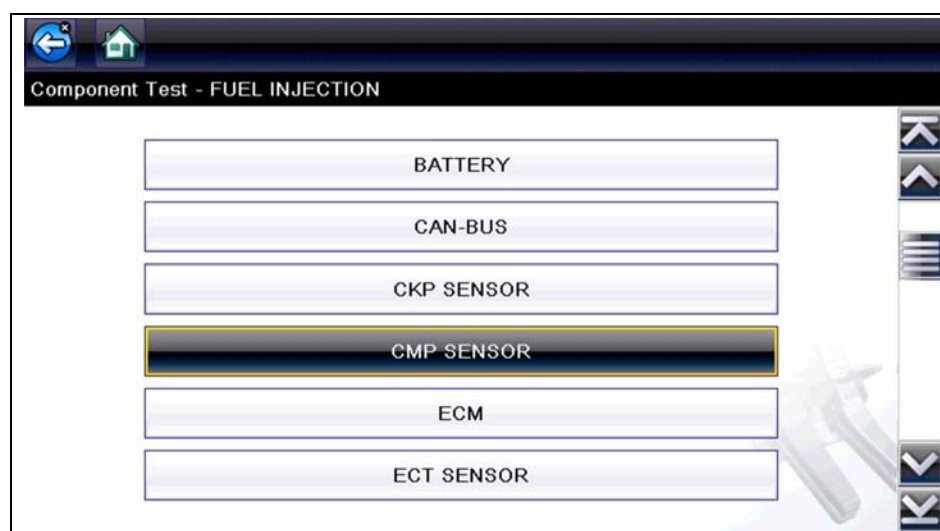

Figure 8-4 Component Menu

Depending on the vehicle and component selected, different options and sub-menus may be displayed. Information and tests may vary:

- **Component Information**— see [Component Information](#), on page 66.
- **Tests**— see [Tests](#), on page 68.
- **Reference Information**—provides identification of components, connector pin location and functions, and abbreviation reference.

8.3.1 Component Information

Component Information provides (if available) specific operational information on the selected component, and may also include electrical connector and pin location and function details



To view component information:

1. Select a component.
2. Select **Component Information** from the Component Test menu ([Figure 8-5](#)).

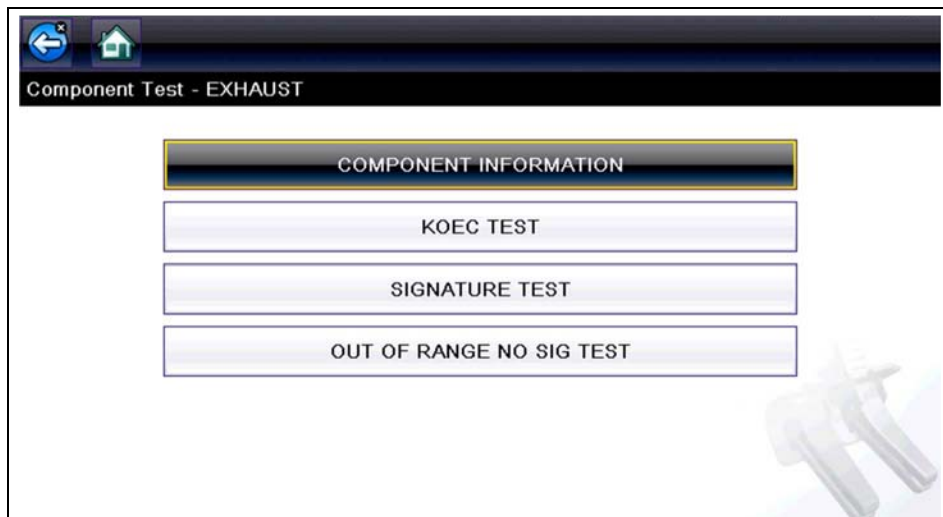

Figure 8-5 Component Tests Menu



NOTE:

An additional selection may be required for some components (e.g. selecting front or rear for an oxygen sensor (O2S)).

Component Information is displayed (Figure 8-6 and Figure 8-7).

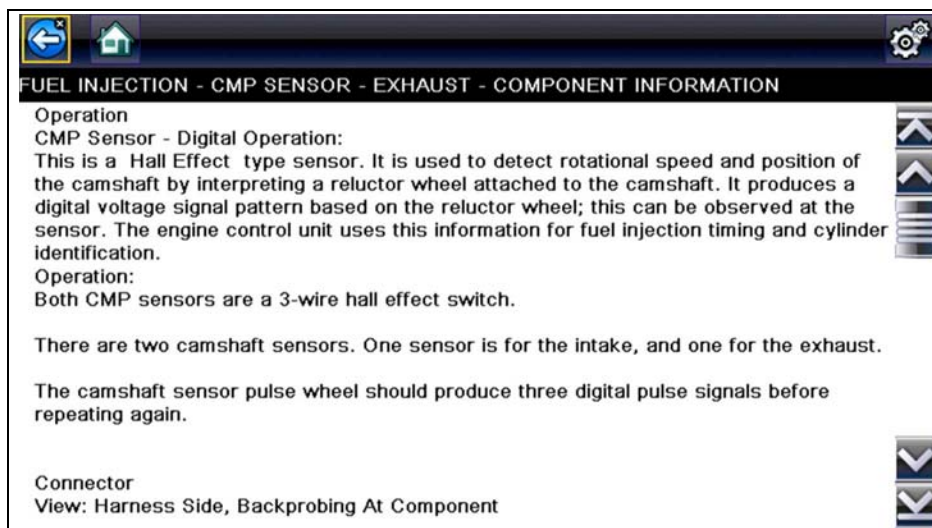

Figure 8-6 Component Information Screen

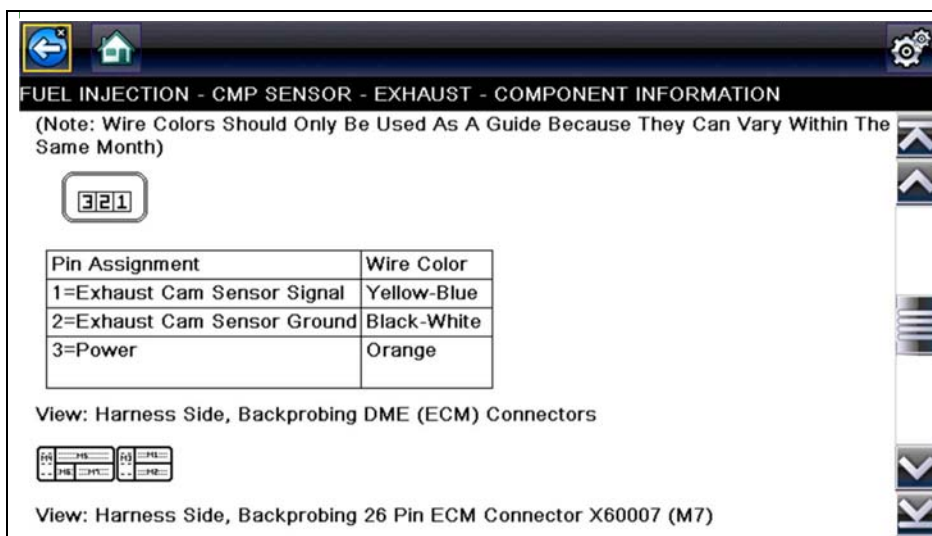

Figure 8-7 Component Information Screen - Continued

Screens are divided into sections to quickly guide you to the correct information (available sections and information will vary):

- **Operation**—provides a general description of component operation.
- **Tech note**—provides component related tips (e.g. common failures or faults), additional information may include OEM service updates and recall information.
- **Connector**—displays illustrated electrical connectors and socket/pin identification.
- **Location**—provides component locations, testing tips, and alternate testing locations if available.

Use the scroll bar to view additional information.

3. Select **Back** on the Toolbar, or press the **N/X** button, to return to the component menu.

8.3.2 Tests

Tests provides (if available) specific instructions to help you perform tests on components. Selecting a component test opens a preconfigured meter to start the test, and may also provide connection instructions, specifications and testing tips.



To select a test:

1. Select a component.
2. Select a **Test** from the Component Test menu ([Figure 8-8](#)).

The component test menu lists all of the tests available for the selected component. Choices vary by the type of component, as well as the make, model, and year of the vehicle.

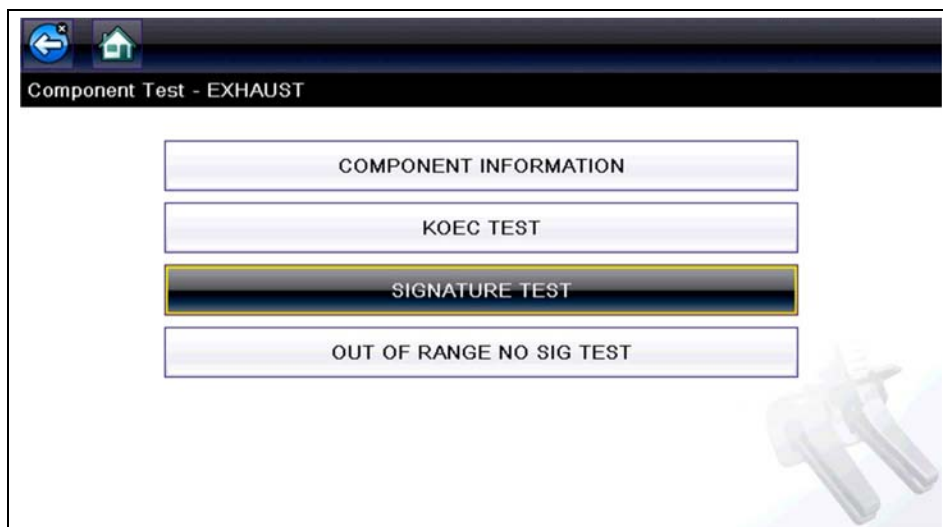

Figure 8-8 Component Test Menu



NOTE:

An additional selection may be required for some Component Tests (e.g. selecting front or rear for an oxygen sensor).

The test screen displays (Figure 8-9).

A Guided Component Test screen initially opens with the information panel below the main body. Use the scrollbar to display hidden information.

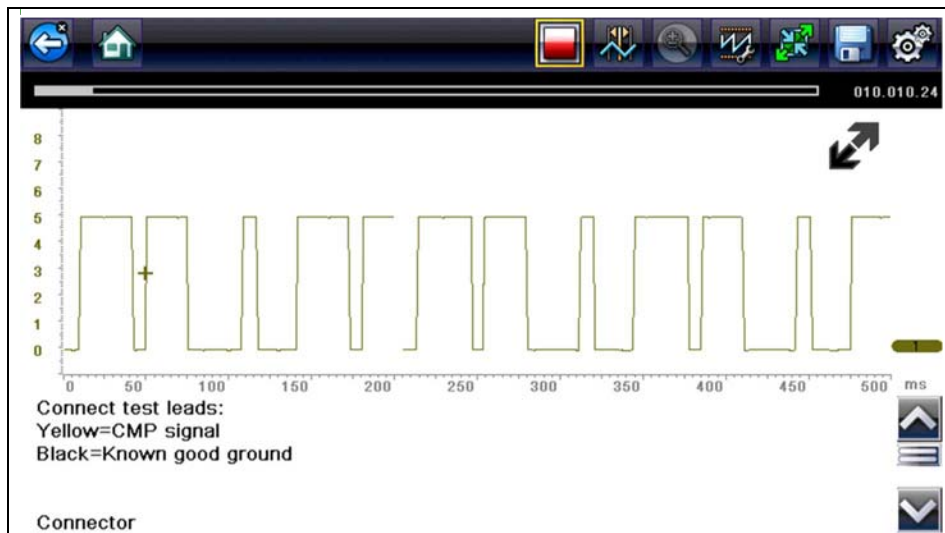

Figure 8-9 Test screen

Tap on the Information Panel once to display the information panel in full screen view. Tap on it again to return to split view. The **Expand/Collapse** icon can also be used to toggle through split and full screen views (Figure 8-10).

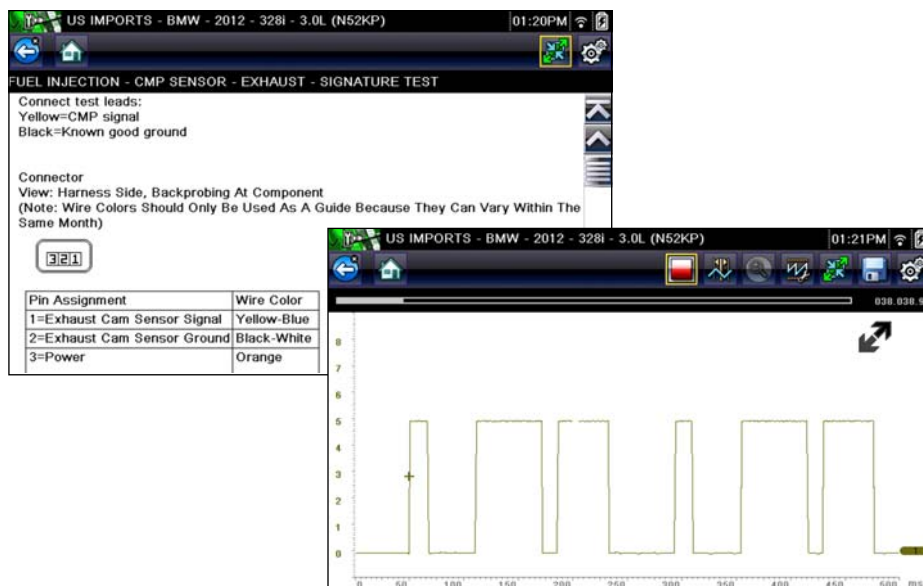

Figure 8-10 View Options

Some tests (e.g. signature integrity tests) may include waveform examples within the information panel. These waveform examples allow you to compare your test results for quick diagnosis (Figure 8-11).

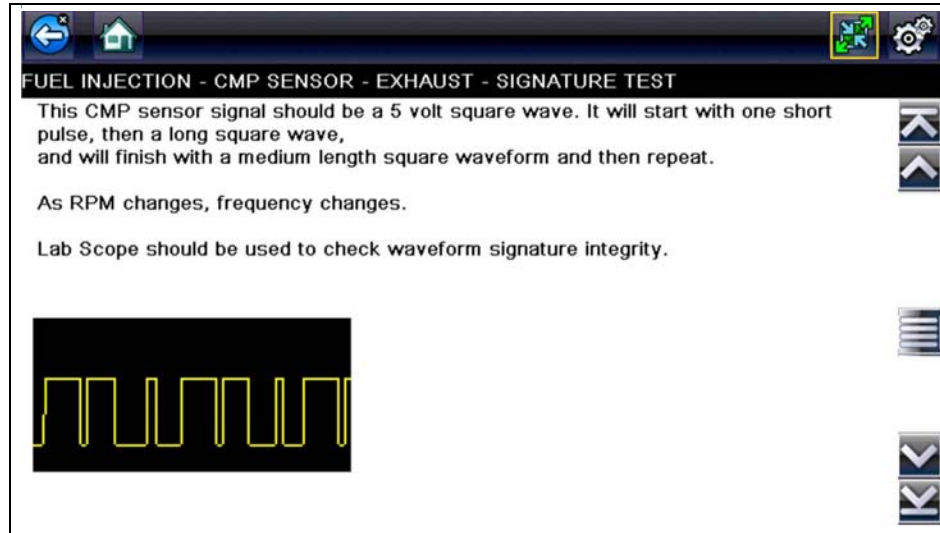

Figure 8-11 Waveform Example

3. Select **Back** on the toolbar to return to the menu.

Channel Settings

The test meter is preconfigured, for most of the component tests. However, if the need to change channel settings is needed, adjustments can be made by selecting the **Control Panel** icon from the toolbar to display the Control Panel (Figure 8-12). For additional information on channel settings, see [Control Panel and Settings](#), on page 89.

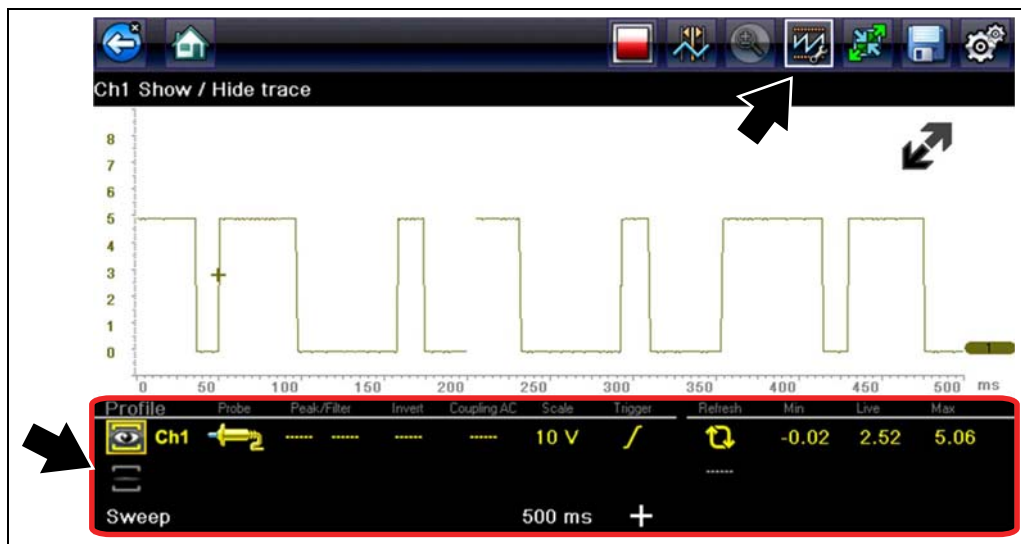

Figure 8-12 Control Panel - Channel Controls

8.3.3 Saving and Reviewing Data Files

Save and Stop control icon operation and data review procedures are the same as used for the Scope/Multimeter function, see [Stopping and Reviewing Data Files](#), on page 112.

This chapter describes the basic operation of the Previous Vehicles and Data function.



The **Previous Vehicles and Data** icon is located on the Home screen. This function allows you to select recently tested vehicles and access saved data files.

9.1 Previous Vehicles and Data Menu

The following options are available from the Previous Vehicles and Data menu:

- [Vehicle History](#)
- [View Saved Data](#), on page 72
- [Delete Saved Data](#), on page 75

9.1.1 Vehicle History

The Diagnostic Tool stores the identification of the last twenty-five vehicles tested, so there is no need to go through the complete vehicle identification sequence when performing a retest after repairs have been made. The oldest vehicle record is deleted when a new vehicle is identified once there are twenty-five vehicles on file.

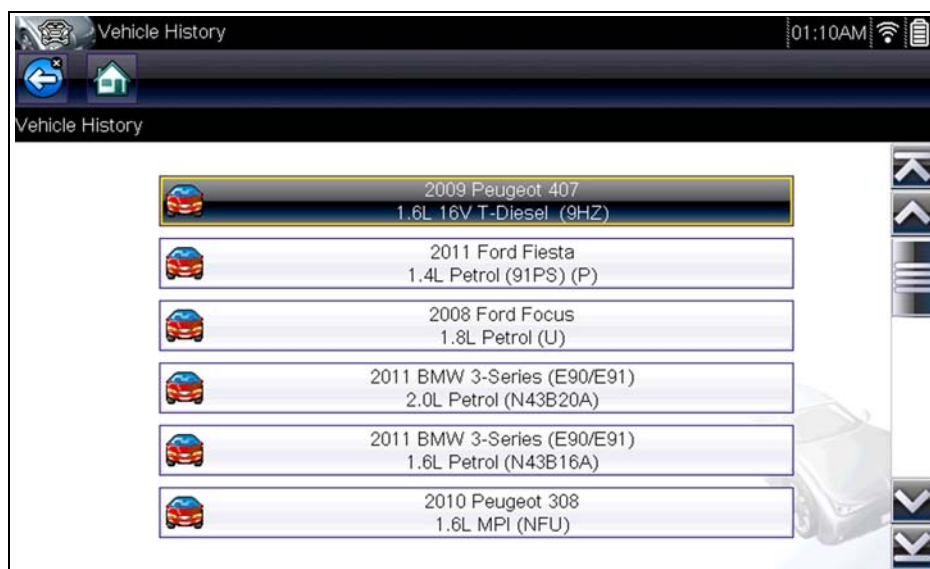

Figure 9-1 Vehicle history list



To select from the vehicle History:

1. Select **Previous Vehicles and Data** from the Home screen.
2. Select **Vehicle History** from the menu.
A list of up to 25 previously tested vehicles displays. Each vehicle is given a unique file name. Scroll to view the entire list.
3. With the item to be opened highlighted, either select the vehicle ID or press the **Y/✓** button.
The appropriate software loads and a vehicle ID confirmation screen displays.
4. Select **OK** or press the **Y/✓** button to continue.
The System Menu for the selected vehicle displays.

9.1.2 View Saved Data

Selecting the **View Saved Data** menu option opens a list of all the saved data (e.g. code scan, scope and pid movies) files and screen images that are stored in memory. Saved files are listed in chronological order by the date and time that they were created with the most recent files are at the top of the list.

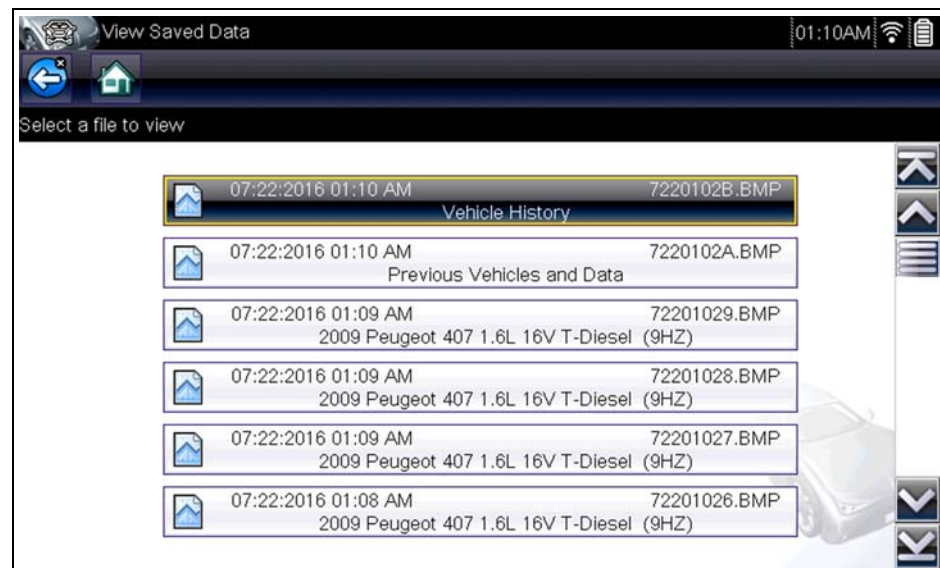

Figure 9-2 Saved data list

Saved files can either be opened directly on the Diagnostic Tool, or downloaded to a personal computer and opened using ShopStream Connect. See [Saving and Reviewing Scanner / OBD-II/EOBD Data Files](#), on page 29, and [ShopStream Connect](#), on page 164 for additional information.



NOTE:

A maximum of 50 files are displayed. To view all (if more than 50) files stored, use ShopStream Connect. See [ShopStream Connect](#), on page 164 for additional information.



To review a saved data file or image:

1. Select **Previous Vehicles and Data** from the Home screen.
2. Select **View Saved Data** from the menu.
3. Select a file to review from the list.

9.1.3 Viewing Codes and Code Scan Results

When code scan or single system code results are saved, they are saved in (.XML) file format (Figure 9-3).

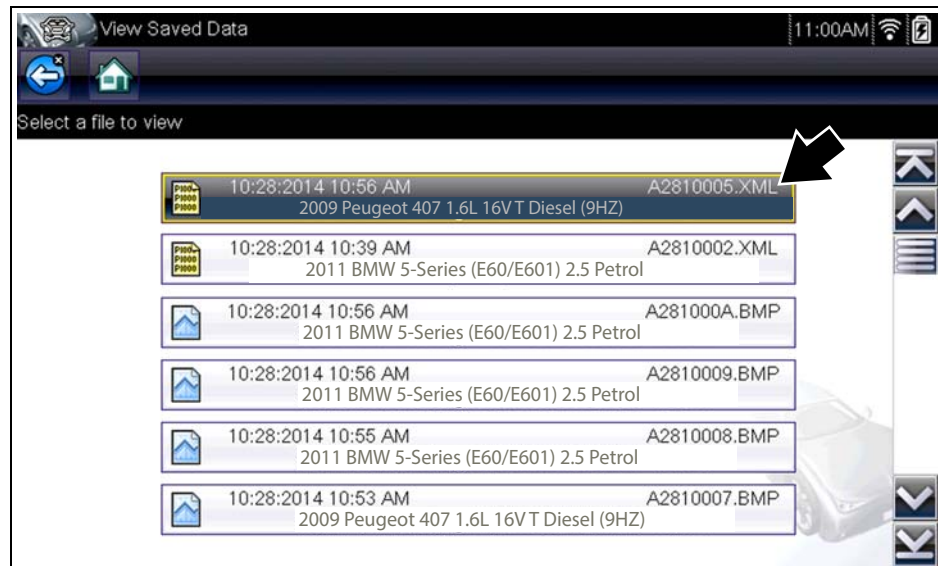

Figure 9-3 Typical - Code Results (.XML) file

The saved (.XML) file(s) can be viewed using two methods:

- On the diagnostic tool - See [Viewing Code Results on the Diagnostic Tool](#), on page 73.
- In Vehicle System Report format using ShopStream Connect - See [Vehicle System Report - Viewing Code Results Using ShopStream Connect](#), on page 74, and [ShopStream Connect](#), on page 164.



Viewing Code Results on the Diagnostic Tool

Selecting a system code or a code scan results file from your saved file list (Figure 9-3), opens the file onscreen (Figure 9-4). When opened, the (.XML) file displays basic vehicle information and a list of DTCs with a brief description of each.

If SureTrack is active and data is available, additional troubleshooting information from SureTrack (e.g. Common Replaced Parts data, Real Fix and Related Fixes) will also be displayed.

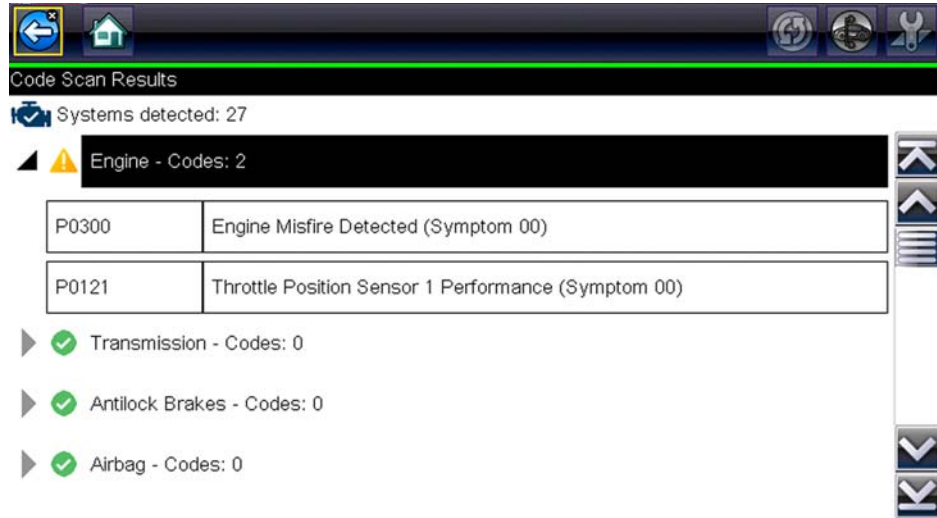

Figure 9-4 Typical - Code Scan Results (.XML file) viewed onscreen



Vehicle System Report - Viewing Code Results Using ShopStream Connect

Saved code scan results can be transferred to a personal computer (PC) using ShopStream Connect, and opened as a printable “Vehicle System Report”, see [ShopStream Connect](#), on page 164, for additional information.

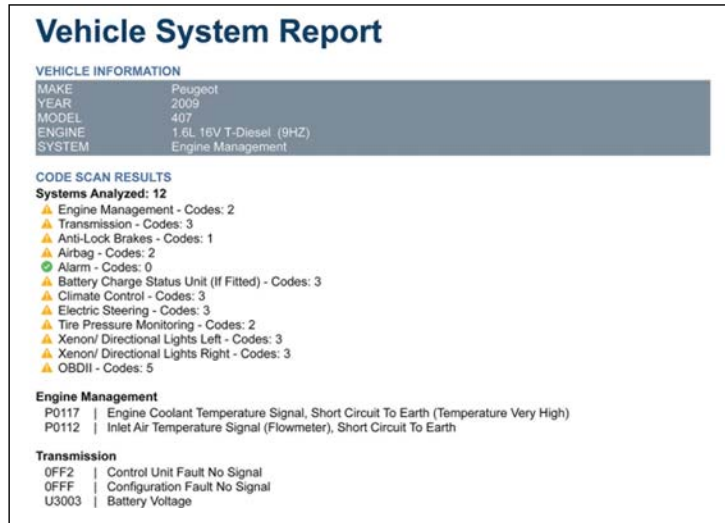

Figure 9-5 Typical - Vehicle System Report (.XML file) viewed in ShopStream Connect

9.1.4 Delete Saved Data

This menu option is used to permanently erase saved files from memory.



To delete a saved file:

1. Select **Previous Vehicles and Data** from the Home screen.
2. Select **Delete Saved Data** from the menu.

A list of saved files displays.



NOTE:

The Select All/Deselect All and Delete icons become available on the toolbar so that you can either delete individual files or clear the entire memory buffer all at once.

3. Select a file from the list and a confirmation message displays.
4. Select an option from the confirmation message:
 - **OK**—deletes the selected file and returns to the saved files list, which no longer includes the deleted file.
 - **Cancel**—returns to the saved files list without deleting the selected file.
5. Select **Back** on the toolbar to return to the Previous Vehicles and Data menu, select **Home** to return to the Home screen.



The Scope Multimeter function allows you to perform multiple types of circuit and component measurement tests. This chapter includes general operation procedures, instructions for saving and reviewing test data, optional settings, and general reference information.

10.1 Overview

The Scope Multimeter test functions are:

- Digital Multimeter (DMM)
- Graphing Multimeter (GMM)
- Lab Scope

10.1.1 Digital Multimeter (DMM)

The digital multimeter gives you the ability to quickly make precise common electrical measurements (e.g. DC and AC voltage, resistance and amperage) on circuits and components to verify operation. The meter displays measurements in a digital numerical format, and is typically used for measuring signals that are not rapidly changing.

The DMM is ideal for performing basic tests on most standard automotive circuits, and displays the results in a large easy to see format.

To use the DMM, select the **Scope Multimeter** icon from the home screen then select **Digital Multimeter** from the menu. See [Tests and Capabilities \(Quick Reference\)](#), on page 79 for a list of available testing functions.

Specifications

Function	Range	Accuracy/Comments
Signal Measurement	Ch. 1— (yellow jack)	Input is referenced to common ground (GND— (black jack)
VDC (Full Scale)	75VDC	Do not measure greater than 75VDC
VAC (Full Scale)	50VAC	Do not measure greater than 50VAC (rms)
Signal Measurement Input Impedance	10 M Ω	-
Ohm Measurement Diode Test Continuity Test	Ch. 1— (yellow jack (-)) Ch. 2— (green jack (+))	-
Ohms	40 Ω —4 M Ω	Fixed scales or auto ranging
Glitch Capture	Approximately 50 μ S	-
Diode test	2V scale	-

10.1.2 Graphing Multimeter (GMM)

Unlike the DMM, the graphing multimeter provides two channels for testing and plots a visual graphing line of the signal instead of displaying digital values. The GMM displays a signal's measurements over time on a two-dimensional grid. This plotted graph is basically a graphical history (histogram) of the signal's measurements over time.

The GMM uses a higher sample rate (than a DMM) to calculate signal measurements. This characteristic along with the visual graph, make the GMM ideal for finding intermittent dropouts or glitches that may not be obvious when viewing a digital value. A key advantage of the GMM is being able to capture a signal over a long time interval and then review its graphical history, to visually see if and when dropouts have occurred.

In addition, the GMM uses a combination of filter and peak detect modes to provide a good balance between detecting fast glitches and preventing unwanted noise from displaying.

Unlike the lab scope, the sweep scales used with typical GMM tests are of longer time intervals, and may range from seconds to minutes, compared to the lab scope sweep scales that use relatively short time intervals (e.g. milli and micro seconds). This allows you to monitor a signal over a longer period of time when looking for erratic glitches or dropouts.

To use the GMM, select the **Scope Multimeter** icon from the home screen then select **Graphing Multimeter** from the menu. See [Tests and Capabilities \(Quick Reference\)](#), on page 79 for a list of available testing functions.

Specifications

Function	Range	Accuracy/Comments
Signal Measurement	Ch. 1— (yellow jack) Ch. 2— (green jack)	Each channel input is referenced to common ground (GND— black jack)
Sample Rate	1.5 MSPS	Continuous sampling, MSPS = mega samples per second
Band Width	3 MHz	3 db point @ 3 MHz
Input Impedance	10 M Ω @ DC 4 k Ω @ 3 MHz	Channel 1 and 2
VDC (Full Scale)	75VDC	Do not measure greater than 75VDC
VAC (Full Scale)	50VAC	Do not measure greater than 50 VAC (rms)
Ohm Measurement Diode Test Continuity Test	Ch. 1— (yellow jack (-)) Ch. 2— (green jack (+))	-
Ohms	40 Ω —4 M Ω	Fixed scales
Low Amp Probe	20A scale (100mV/Amp) 40A scale (10mV/Amp) 60A scale (10mV/Amp)	Connect the positive (+) Amp Probe lead to the yellow jack on the diagnostic tool for values on Ch. 1, or to the green jack for values on Ch. 2. Connect the negative (-) lead to GND (black jack) ¹ .
1. Do not use the Low Amp Probe to measure current on conductors at a potential greater than 46VAC peak or 70VDC.		

10.1.3 Lab Scope

Similar to the GMM, the lab scope (oscilloscope) plots a visual image line of a signal's measurements over time on a two-dimensional grid. The visual line that is displayed is commonly called a trace, and the graphical form created by a signal is called a waveform.

Unlike the DMM, the lab scope allows you to visually see a signal's waveform, which in turn allows you to see the strength and shape of the signal, as well as any noise that may be occurring on the circuit. The lab scope also samples signals at a high rate, which allows you to see a higher level of detail in short samples of the signal, especially in signals that change rapidly. In addition, the lab scope also provides more control over the acquisition of the signal and in how it is displayed, through the use of triggers and channel controls. All of these features allow you to analyze signals in great detail when performing diagnostics.

To use the lab scope, select the **Scope Multimeter** icon from the home screen then select **Lab Scope** from the menu. See [Tests and Capabilities \(Quick Reference\)](#), on page 79 for a list of available testing functions.

Specifications

Function	Range	Accuracy/Comments
Signal Measurement	Ch. 1— (yellow jack) Ch. 2— (green jack)	Each channel input is referenced to common ground (GND— black jack)
Sample Rate	For 50 μ S sweep 6 (MS/s) For 100 μ S sweep 3 (MS/s) For all other sweeps 1.5 (MS/s)	Continuous sampling, (MS/s) = mega samples per second
Band Width	3 MHz	3 db point @ 3 MHz
Input Impedance	10 M Ω @ DC 4 k Ω @ 3 MHz	Channel 1 and 2
VDC (Full Scale)	100mV–400V	Do not measure greater than 75VDC
VAC (Full Scale)	100mV–400V	Do not measure greater than 50 VAC (rms)
Low Amp Probe	20A scale (100mV/Amp) 40A scale (10mV/Amp) 60A scale (10mV/Amp)	Connect the positive (+) Amp Probe lead to the yellow jack on the diagnostic tool for values on Ch. 1, or to the green jack for values on Ch. 2. Connect the negative (–) lead to GND (black jack) ¹ .
1. Do not use the Low Amp Probe to measure current on conductors at a potential greater than 46VAC peak or 70VDC.		

10.2 Tests and Capabilities (Quick Reference)

The following chart identifies and describes available tests by function.



NOTE:

Not all the tests listed are described in this manual. This list is intended as reference only.

D M M	G M M	LS	Test	Function
		✓	Two Channel Lab Scope	Displays two Lab Scope channels automatically
	✓		Dual Graphing Meter	Displays two Graphing Multimeter channels automatically
		✓	Ignition Probe	Measures secondary Ignition voltage 2 to 50kV. Displays secondary ignition (kV) waveforms.
✓	✓	✓	Volts DC	Measures direct current voltage. DC voltage is measured through the two test leads connected to a DC circuit.
✓	✓		Volts DC - Average	Measures DC voltage using a filter to determine the average voltage over a period in time. DC voltage is measured through the two test leads connected to a DC circuit.
✓	✓		Volts AC RMS	Measures the effective AC voltage, not the peak voltage which results in measurements with higher accuracy. The AC RMS (root mean square) voltage value can be defined as the equivalent DC voltage of the AC voltage measured. RMS values are commonly used in AC electrical measurement, as they are more representative of DC measurements.
✓	✓		Ohms (Ω)	Measures electrical resistance (opposition to current) 0 to 4 M Ω . Scope supplied DC current is passed through the circuit to measure the resistance between the two connected test leads.
✓			Diode/Continuity	Measures voltage drop across a diode and continuity through a diode. Scope supplied DC current is passed through the diode to measure the voltage drop between the two connected test leads. Typical setup for positive to negative current flow - positive lead (anode +/side) and negative (cathode -/side)
	✓		Frequency	Measures the number of times a signal repeats itself per second. Used to measure frequency of signals such as CKP, CMP and wheel speed sensors.
	✓		Pulse Width	Measures the on-time of various components (e.g. components that cycle on and off like the EGR, or canister purge).
	✓		Injector Pulse Width	Measures fuel injector on-time when checking for variances when engine load is changed and/or physical problems with the injector
	✓		Duty Cycle	Measures the ratio of the pulse width to the complete cycle width, the on-time of components that cycle on and off like EGR, or canister purge from 0–100%
✓	✓	✓	Low Amps (20)	Used to measure amperage of typical devices (e.g. ignition coils, injectors, fuel pumps) that may draw up to 20A peak (startup) when initially started. Also used to measure parasitic draw.

D M M	G M M	LS	Test	Function
✓	✓	✓	Low Amps (40)	Used to measure amperage of typical motors and devices that may draw up to 40A peak (startup) when initially started.
✓	✓	✓	Low Amps (60)	Used to measure amperage of larger motors and devices that may draw up to 60A peak (startup) when initially started.
	✓		MC Dwell (60)	Measures carburetor Mixture Control Solenoids (0–60°). The duty cycle of the solenoid is expressed in the dwell angle of a 6 cylinder engine: 100% = 60 deg.
	✓		MC Dwell (90)	Measures fuel system Mixture Control Solenoids (0–90°). The duty cycle of the solenoid is expressed in the dwell angle of a 4 cylinder engine: 100% = 90 deg.
	✓	✓	100 PSI Vacuum	Used to measure vacuum up to 20 in.Hg, using the 0–100 psi transducer
	✓	✓	100 PSI Pressure	Used to measure pressures for typical systems such as, fuel, oil, EVAP, hydraulic/transmission fluid etc. up to 100 psi, using the 0–100 psi transducer
	✓	✓	500 PSI Pressure	Used to measure pressures for typical systems such as, hydraulic/transmission fluid pressure, cylinder compression, and AC high side up to 500 psi, using the 0–500 psi transducer
	✓	✓	5000 PSI Pressure	Used to measure pressures for typical systems such as, ABS, power steering, and heavy-duty hydraulic system fluid up to 5000 psi, using the 0–5000 psi transducer
	✓	✓	MT5030 Vacuum	Used to measure vacuum up to 29 in.Hg, using the MT5030 pressure transducer adapter
	✓	✓	MT5030 Pressure	Used to measure fluid and gas pressures up to 500 psi, using the MT5030 pressure transducer adapter
	✓	✓	EEDM506D Temperature	Used to measure temperatures from -50° to 1800° F (-45 to 982° C), using the EEDM506D pressure transducer adapter

10.3 Test Leads and Accessories

Some of the leads, probes and adapters supplied with or that may be available, are explained in the following section.



NOTE:

Not all test leads and/or accessories may be available in all markets. Contact your sales representative for information, or to find out more about these and other available accessories.

IMPORTANT:

Avoid damaging test leads, do not pull on the wire when removing the leads from their jacks. Pull only on the lead terminal end.

10.3.1 Channel 1 Lead

The shielded yellow lead is used with channel 1, and is color matched with the channel 1 jack on the diagnostic tool.

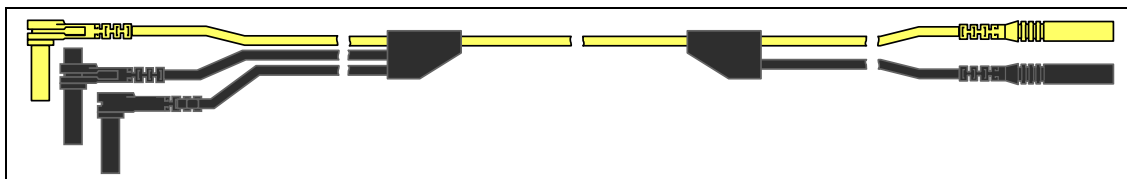

Figure 10-1 Yellow Channel 1 Lead

This lead also includes two black, right-angle common ground plugs. One plug is standard and the other is stackable. The standard ground plug should always be connected to the ground (GND) jack on the diagnostic tool.

The stackable ground plug is used for connecting additional ground leads, such as the Channel 2 or the Secondary Coil Adapter lead grounds. The stackable ground lead is internally connected to the standard ground lead, therefore it does not need to be connected to the diagnostic tool ground jack.

10.3.2 Channel 2 Lead

The shielded green lead is used with channel 2, and is color matched with the channel 2 jack on the diagnostic tool. This lead also includes a black, right-angle stackable ground plug.



Figure 10-2 Green Channel 2 lead

10.3.3 Alligator Clips and Probes

Insulated alligator clips and probes (pointed type) can be attached to the end of the test leads. Each alligator clip is color matched with a test lead, and the probes are available in red and black.

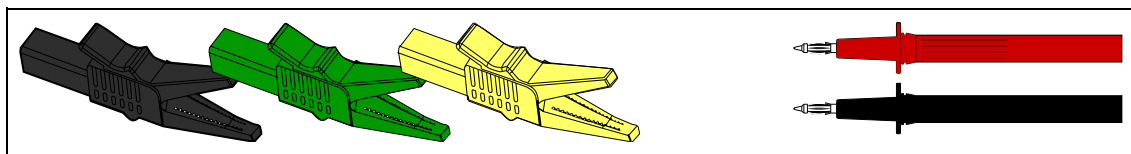

Figure 10-3 Alligator clips

10.3.4 Secondary Ignition Coil Adapter Lead and Clip-on Adapter (optional)

The secondary ignition adapter lead can be used with the secondary ignition clip-on wire adapter, coil-in-cap (CIC), or coil-on-plug (COP) secondary ignition adapters to display secondary ignition signals. The clip-on adapter clips over a secondary ignition wire to pickup a signal, and the CIC and COP adapters attach to the ignition coil. The coil adapter lead includes a black, right-angle stackable ground plug, and a RCA type connector that is used to connect the lead to a secondary ignition adapter. The spring clamp is used to connect to a ground.

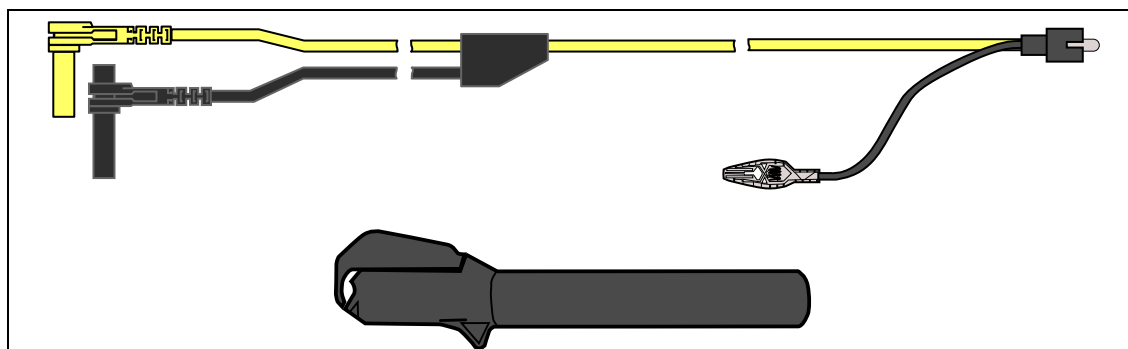

Figure 10-4 Secondary Ignition Coil Adapter Lead and Clip-on Wire Adapter



NOTE:

Contact your sales representative for additional information on OEM specific CIC and COP secondary ignition adapters.

10.3.5 Low Amp Current Probe (optional)

The Low Amp Current Probe is used measure AC or DC current up to 60A. This probe includes two scales (0 to 20A) and (0 to 60A) that can be used to provide accurate and reliable non-intrusive current measurement for components such as, ignition coils, fuel injectors, fuel pumps, relays, and electric motors.



Figure 10-5 Low Amp Current Probe

10.3.6 Pressure Transducers and Adapters (optional)

Different pressure transducers and adapters are available for measuring positive and negative gas and liquid pressures. Depending on the adapter, measurement capabilities range from 1 to 5000 psi and up to 29 inHg. Measurement and application capabilities vary per device.



Figure 10-6

10.4 General Information

This section describes the general Scope Multimeter control icon functions, screen layout and optional settings. The screen layout and control icon functions are shared between the digital/graphing multimeters and lab scope.



NOTE:

Scope and Multimeter tests are not vehicle specific, therefore vehicle identification is not required.

10.4.1 Scope Multimeter Screen Layout and Features







- 1— **Toolbar**—contains navigational and control icons
- 2— **Data Buffer Position Indicators**—graphical and numerical position indicators
- 3— **Main Body**—contains the meter/scope display
- 4— **Control Panel**—contains channel/trace controls
- 5— **Expand/Collapse icon**—toggles display between split and full screen views

Figure 10-7

Scope Multimeter Control Icons

The following control icons are common across most Scope Multimeter functions, however use may vary depending on the active function or test. A yellow frame surrounding an icon (highlighted), indicates it is selected. Other control icons (not shown) are described in [Common Toolbar Control Icons](#), on page 12.

Icon	Function
	<p>Stop - Stops the data buffer</p>
	<p>Control Panel - (a). In full screen mode, when selected this icon becomes surrounded by a white frame and opens the control panel at the bottom of the screen while switching active selection focus to the Show/Hide or Probe icon in the Control Panel. (b). In split screen mode (control panel open), when selected this icon becomes surrounded by a white frame and switches active selection focus to the Show/Hide or Probe icon in the Control Panel.</p> <p>Note: Switching active selection focus to the Control Panel allows manual navigation (using the directional control buttons) of the Control Panel control icons</p>
	<p>Zoom - Increases and decreases screen magnification. The zoom function is only available during data review (scope stopped).</p>
	<p>Cursors - Toggles cursors on/off.</p>

Main Body

The main body may display the following:

- Menu - Select from a menu using the touch screen or the control buttons.
- Meter/Scope Display - Up to two signal traces can be displayed simultaneously. Each trace is displayed as voltage over time and the voltage level is recorded on the vertical, or “y”, axis and time is presented on the horizontal, or “x”, axis of the screen.

Data Buffer Position Indicators

The graphing multimeter and lab scope functions have the capability to save, store and playback, data (signals) utilizing internal storage “buffer” memory.

The Data Buffer Position Indicators are used to visually see the overall amount and position of the of stored buffer data during saving and playback.

For additional information on the Data Buffer, Data Buffer Position Indicator and Saving, Storing and Reviewing Data files, see [Saving and Reviewing Scope / Multimeter Data Files](#), on page 110.

10.4.2 Measurement Out of Range (Alert)

When performing a test, if a group of arrows displays onscreen, this indicates that the measurement is out of range for the scale selected.

- Arrows pointing UP—measurement over maximum range
- Arrows pointing DOWN—measurement under minimum range

Voltage measurements also display arrows in place of live values when the voltage exceeds the input rating of the meter.

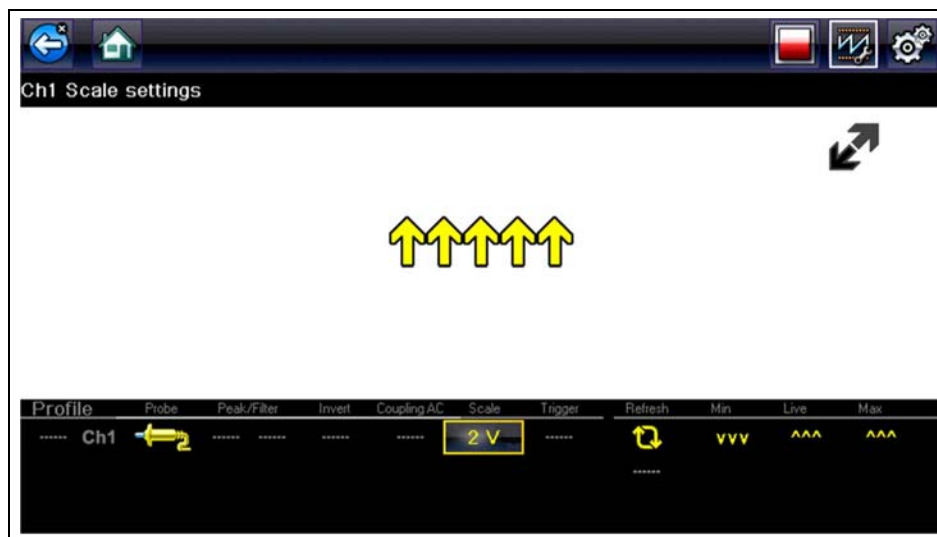

Figure 10-8

WARNING



Risk of electrical shock.

- **Do not exceed voltage limits between inputs as indicated on the rating label.**
- **Use extreme caution when working with circuits that have greater than 40 volts AC or 24 volts DC.**

Electrical shock can cause personal injury, equipment damage, or circuit damage.

IMPORTANT:

If arrows are displayed in the live voltage values, discontinue circuit testing.

Correct an out-of-range condition by selecting a scale setting appropriate for the signal being sampled. See [Scale \(Vertical scale adjustment\)](#), on page 90 for more information.

10.5 Operation and Controls

This section describes the general operation and controls used to configure the scope or meter to perform testing. All three functions share similar control panel settings, see [Control Panel and Settings](#), on page 89 for additional information.

**NOTE:**

The information in the following sections is intended as a guide and general overview of the controls and functions used within the Scope Multimeter. Not all the settings or controls described throughout this section are applicable with all functions.

**To open a scope multimeter function:**

1. Select the **Scope Multimeter** icon from the home screen.
2. Select either **Lab Scope**, **Graphing Multimeter** or **Digital Multimeter** from the menu.

10.5.1 Test Lead / Probe Connection

Standard “safety type” test lead jacks are located on the top of the diagnostic tool, and are compatible with many test leads and probes. Insert the applicable test lead or probe terminal end into the jack to complete the connection.

IMPORTANT:

To avoid damaging test leads, do not pull on the wire when removing the leads from their jacks. Pull only on the lead terminal end.

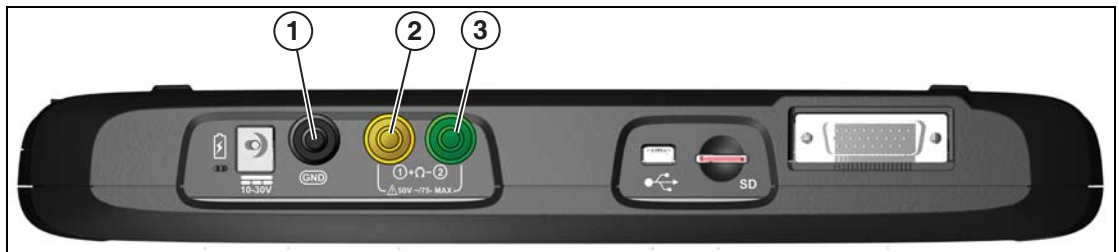

1— Ground Jack (Black)

2— Channel 1 Jack (Yellow)

3— Channel 2 Jack (Green)

Figure 10-9 Scope Multimeter Test Lead Jacks

10.5.2 Test Lead / Probe Calibration

Certain tests may display a confirmation prompt asking “Do you wish to calibrate this probe?” before continuing with the test. As general practice, it is important to ensure the test probe is calibrated before testing, to ensure accurate results.

Typical resistance, pressure, and vacuum tests will display the calibration message, reminding you to calibrate the probe. To perform the probe calibration, select **Yes** at the prompt and continue to follow the onscreen instructions to complete the calibration.

Example: For the ohms (resistance) calibration process, once completed, zero ohms should be displayed when the leads are connected together. When the leads are separated, the upward arrows on the display indicate infinite resistance or an open circuit.



NOTE:

During an ohms test or a pressure test, a manual probe recalibration can be initiated by selecting the probe icon from the Control Panel to open the probe menu. Then select either the **Ohms** or **Pressure (100, 500, 5000)** items from the probe menu. The menu selections will display a graphic of a balance scale with an “X” through it (on right side) to indicate that probe is not calibrated.

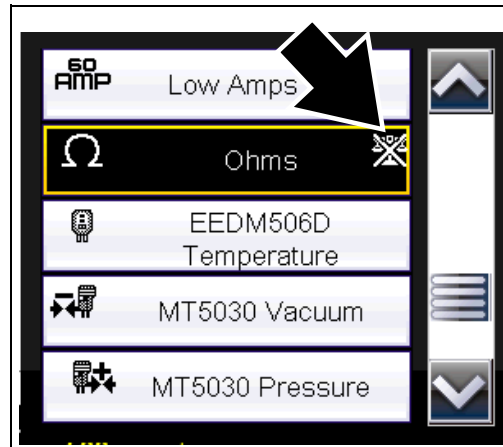

Figure 10-10 Probe menu - Ohms with “not calibrated” indicator displayed

10.5.3 Control Panel and Settings

The control panel is common to all three Scope Multimeter functions, and contains the channel (or “trace”) settings and controls that are used to monitor and adjust the signal being measured. This section provides a general overview of all the channel settings and control features used across all three Scope Multimeter functions.



NOTE:

This section is intended as a general overview of the channel settings. Not all the settings or controls described in this section are applicable with all functions, some may be “grayed out” or not active (applicable) depending on the function or test. Function availability is noted as applicable.



NOTE:

The control panel can be toggled on/off by selecting the Expand/Collapse Icon to switch the screen between full and split test meter views.

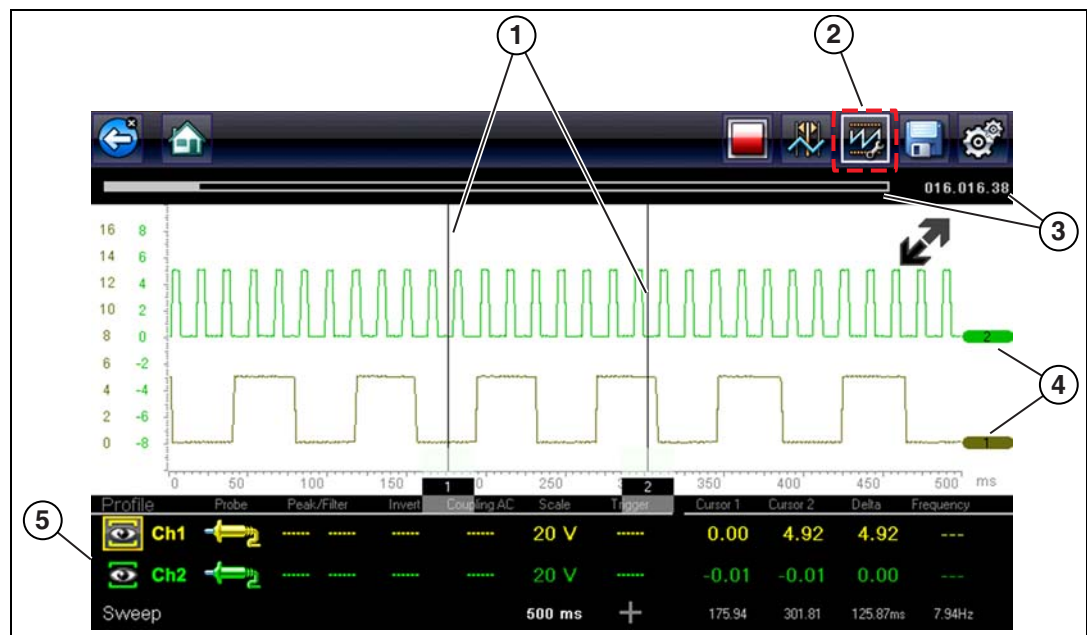

- 1— Cursors
- 2— Control Panel Icon
- 3— Data Buffer Position Indicators—graphical and numerical position indicators
- 4— Zero Base Line Indicators
- 5— Control Panel—contains channel/trace controls and settings

Figure 10-11

Scale, Sweep and Probe Settings

The most common and typically the first adjustments made when performing tests are the setup or adjustment of the scales and selection of a probe. All three of these adjustments are made from the control panel and are described in the following sections.

The following illustration is for reference, and identifies key terms and features used throughout the following sections:

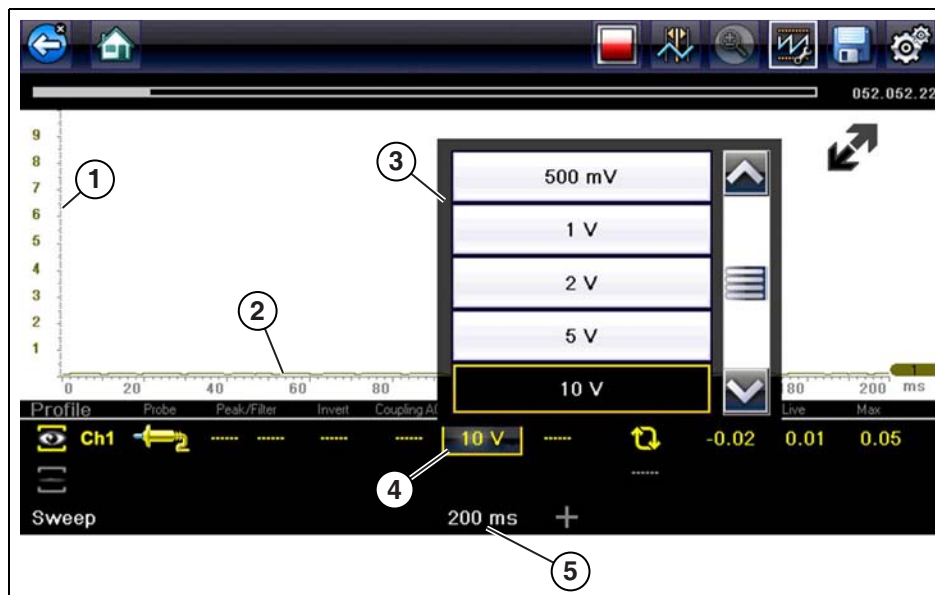

- 1— Vertical Scale - [Y axis]
- 2— Horizontal (sweep or time) Scale - [X axis]
- 3— Vertical Scale Menu
- 4— Vertical Scale Icon
- 5— Sweep Scale Icon

Figure 10-12

Scale (Vertical scale adjustment)

The vertical scale (Y-axis) represents what is being measured (voltage, amperage, pressure etc.), and the unit of measurement it is being measured in. The vertical scale is “always” divided into 10 major divisions; how these divisions are defined, sets the scale of measurement.



NOTE:

Vertical scales (either channel) can be set independently.



NOTE:

Optional vertical scale preference settings are available. The Divisions option allow you to change (to your preference) how the vertical scale menu selections are represented, and the type of value that displays in the vertical scale icon. See [Divisions](#), on page 107.

To adjust the vertical scale unit of measurement, select the **Vertical Scale** icon to open the vertical scale menu. Select a value then press the **N/X** button, to exit the menu. The value displayed in the vertical scale icon indicates the active value.

Example: Selecting 10V, changes the vertical scale to a 10V volt scale. The scale is “always” divided by 10, therefore each division is incremented by 1V.

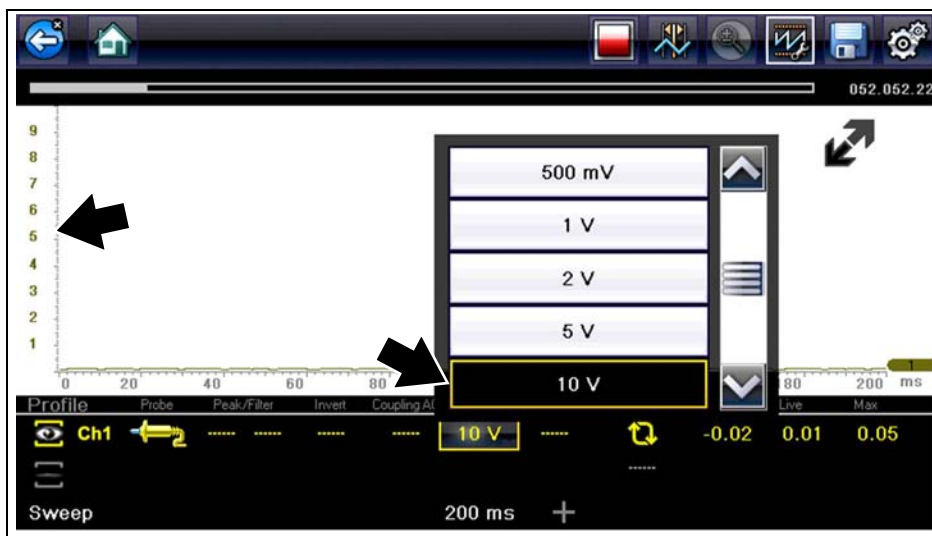

Figure 10-13

Example: Selecting 50 psi displays a 50 psi scale that is divided by 10, therefore each division is incremented by 5 psi.

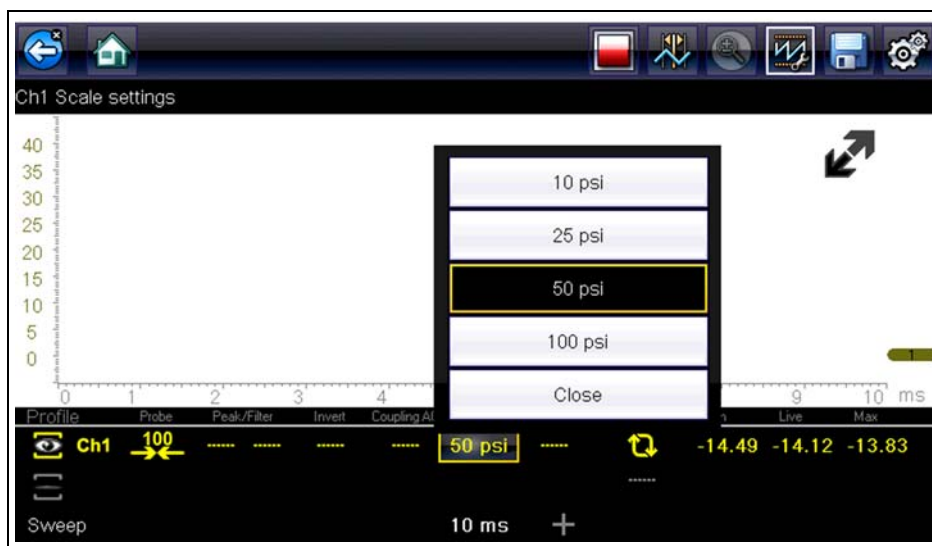

Figure 10-14

Sweep (Horizontal or Time scale adjustment)

The horizontal scale (X-axis) represents time, and the unit of measurement it is being measured in. The horizontal scale is “always” divided into 10 major divisions, how these divisions are defined, sets the scale of measurement. The value displayed in the sweep Scale icon indicates the active sweep setting.



NOTE: The sweep setting applies to all channels and cannot be set independently per channel.

To adjust the sweep scale unit of measurement value, select the Sweep Scale icon to open the sweep scale menu. Select a value then press the **N/X** button, to exit the menu.

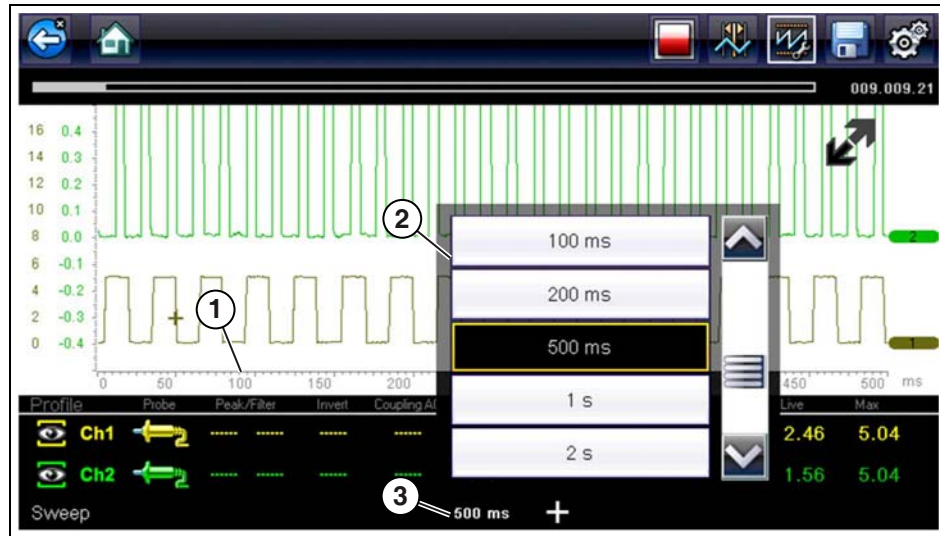

- 1— Sweep Scale
- 2— Sweep Scale Menu
- 3— Sweep Scale Icon

Figure 10-15

Example: Selecting 500ms, changes the sweep scale to a 500ms scale. The scale is “always” divided by 10, therefore each division is incremented by 50ms.

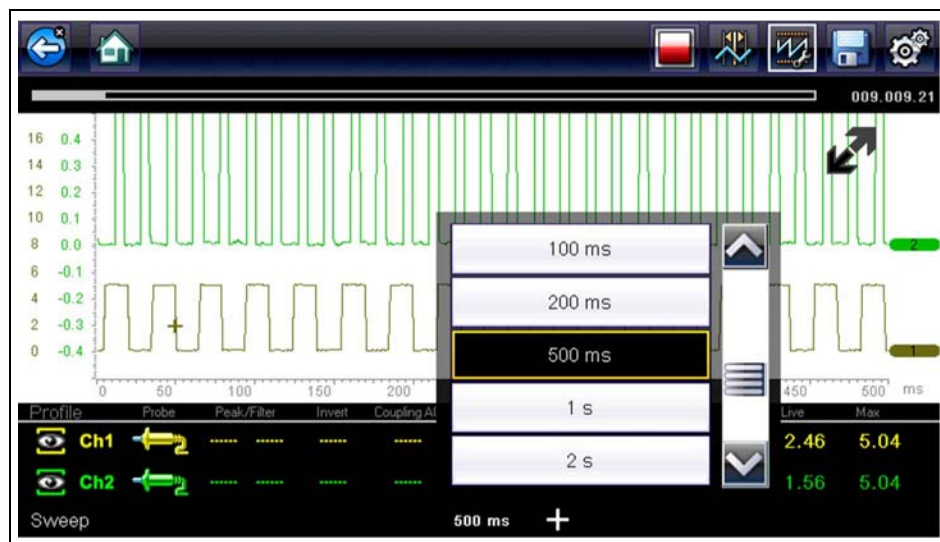

Figure 10-16

Probe (Probe type “test” selection)

Different types of Probes are available from the probe option menu, depending on which type of test you are performing. Changing the probe selection, also changes the vertical scale to the applicable type of measurement.

To select a Probe type, select the **Probe** icon to open the probe option menu, then select a probe. The probe icon will change to the selected probe. Select **Close** from the menu to close the menu.

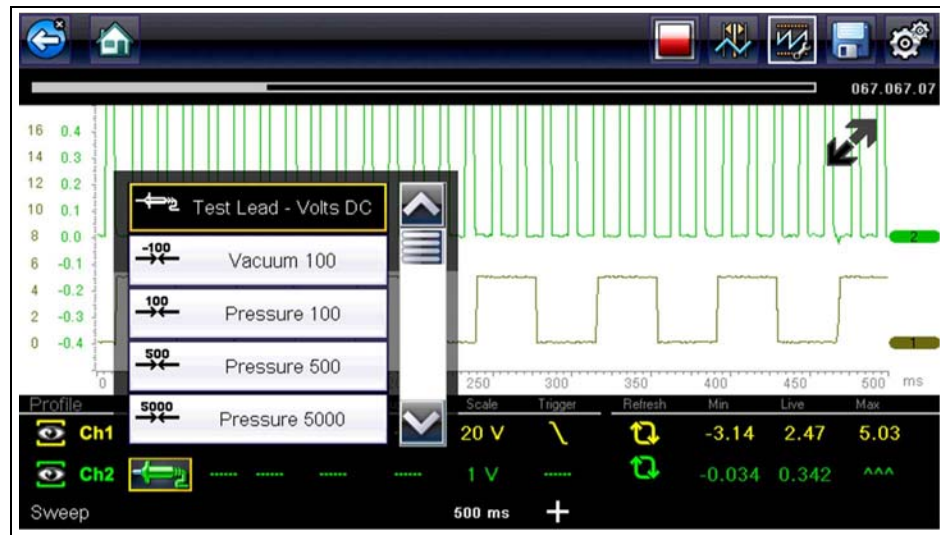

Figure 10-17 Probe option menu

For probe calibration information, see [Test Lead / Probe Calibration](#), on page 88.

Probe “test” Options	
Menu Option	Probe / Device Used
Test Lead - Volts DC	Standard Channel 1 and 2 test leads with alligator clips or test probes
Vacuum 100	(optional) 0-100 psi pressure transducer with pressure adapter
Pressure 100	
Pressure 500	(optional) 0-500 psi pressure transducer with pressure adapter
Pressure 5000	(optional) 0-5000 psi pressure transducer with pressure adapter
Low Amps 20	(optional) Low Amp Probe
Low Amps 40	
Low Amps 60	
Ignition	(optional) Secondary ignition adapter lead with desired secondary ignition coil adapter
EEDM506D Temperature	(optional) Part number - EEDM506D temperature adapter
MT5030 Vacuum	(optional) Part number - EEDM5030 0-500 pressure adapter
MT5030 Pressure	

Channel Settings

The majority of the channel (trace) settings and controls are located in the Control Panel. Each setting is represented by an icon, or a value. Icons are used to make adjustments, and the displayed values represent an individual characteristic. Depending on the test, applicable settings are displayed. The following image shows different views of the control panels to identify the different controls.





- 1— **Show/Hide (Channel display on/off)**—turns channel on/off
- 2— **Trace (Zero Baseline position adjustment)**—adjusts zero baseline position
- 3— **Probe (Probe type “test” selection)**—changes test probe function
- 4— **Peak Detect**—maximizes sampling rate
- 5— **Filter**—removes signal noise or interference
- 6— **Invert**—switches signal polarity
- 7— **Coupling AC**—blocks the DC portion of signal
- 8— **Scale (Vertical scale adjustment)**—adjusts vertical scale
- 9— **Trigger**—turns triggering on/off, and sets direction of trigger slope
- 10— **Refresh**—clears Min, Max and Live values and resets to zero
- 11— **Min, Live and Max Display Panel**—displays lowest, highest and current trace measurements set since the test was activated
- 12— **Sweep (Horizontal or Time scale adjustment)**—adjusts horizontal scale
- 13— **Trigger Position Icon**—opens trigger position control panel
- 14— **Threshold**—turns auto threshold on, to provide a more accurate measurement on select tests where noise is present (GMM only)
- 15— **Cursors**—used to measure time, amplitude and frequency
- 16— **Cursor Measurements Panel**—displays signal amplitude at cursor and cursor position in time

Figure 10-18

Show/Hide (Channel display on/off)

The Show/Hide icons allow you to turn the channels on and off.

To turn a channel on and off, select the applicable channel's **Show/Hide** icon.

Show/Hide Icons	
On (Channel displayed)	Off (Channel not displayed)
	

Trace (Zero Baseline position adjustment)

The Trace icon identifies the channel number and is used to open the zero baseline adjustment controls.

To adjust the vertical position of the zero baseline (0 value) of a trace (for either channel), select the **Trace** icon or to open the zero baseline adjustment controls. Select the up/down arrows to make adjustments or press the up/down directional buttons. Tap the main body screen section or press the **N/X** button, to exit.

The zero baseline can also be repositioned by touching and dragging the baseline marker up/down on the screen.

Trace Icon

Peak Detect

Peak Detect Off

When peak detect is off, the scope samples at a high rate but saves just enough sample points to the data buffer memory to plot a waveform across the screen. No preference is given to any point during the selection process.



NOTES:

- Turning peak detect “off” is suitable for basic measurements, and viewing waveforms (e.g. oxygen (O2) or Cam sensor) when capturing fast events is not necessary.
- The longer the time sweep, the greater the chance a glitch could be missed because it occurred in between the sample points saved to the data buffer memory. To increase the chance of capturing a glitch with peak detect “off”, a shorter time sweep should be selected.
- Turing peak detect “off” avoids the need for an external filter to decrease the display of unwanted noise, which can make diagnosis more difficult.

Example: *With a time sweep of 10 seconds on a screen 100 points wide, the effective sample rate would be 10 times a second. Decreasing the time sweep to 1 second, increases the effective sample rate to 100 times a second. At this time setting, a fast occurring event is more likely to be captured due to the increased rate. This is the standard mode of operation for many scopes.*

Peak Detect On



When peak detect is “on”, all sample points are evaluated. The points stored to the data buffer memory are intelligently selected to capture fast events that might be missed at slower effective sample rates. Peak Detect captures fast events, spikes and glitches for signals going in both positive and negative directions.



NOTES:

- Turn peak detect "on" when capturing fast events (e.g. ignition firing voltage, glitches, and intermittent events).
- Turning peak detect “on” may capture unwanted noise, therefore, using peak detect may not be suitable for some tests (e.g. oxygen (O₂) sensor), as the waveform may be more difficult to evaluate due to the additional noise that may be displayed.
- Peak Detect decreases the possibility of waveform aliasing.

To turn peak detect on and off, select the **Peak Detect** icon.

Peak Detect Icons	
On (Sampling maximized)	Off (Sampling not maximized)
	

Filter

Using the filter feature can minimize or smooth out signal spikes and fast variations, depending on which function is its used with.

Filter - Lab Scope

Using the filter with the lab scope, smooths out fast spikes, which helps to provide a good balance between noise suppression and signal integrity.

Using the filter is useful when working with scales of 5 volts and below, as the lower the voltage scale, the more likely noise can occur.

Example: *Using the filter is helpful when testing components such as, an O₂ sensor (1or 2 volt scale), or when performing a throttle position (TP) sensor sweep test (5 volt scale).*

In addition, the filter is also helpful for low amp probe tests, as a low voltage scale is used to measure the output of the probe (due to the conversion factors of the probe).



Example: *For a probe with a conversion factor of 100 mV/A connected to a 2 amp load, the scope uses a 200 mV scale to measure the output of the probe. The scope converts the measured output to 2 amps for display on the screen.*

Filter - GMM

Using the filter with the GMM, the filter minimizes noise by ignoring or smoothing out fast signal spikes.

- For a direct measurement test, such as volts, amps, or pressure, the filter minimizes the display of very fast spikes by averaging the sampled data when filter is active.
- For a calculated measurement test, such as frequency, pulse width, dwell, or duty cycle, extremely fast spikes (20 μ S and faster) from sources like the ignition system are ignored when filter is active.

To turn the filter on and off, select the **Filter** icon.



Filter Icons	
On (Interference is suppressed)	Off (Interference is not suppressed)
	

Invert

The Invert feature is used to switch signal polarity, so the trace appears upside down (inverted) on the screen. This is typically used when measuring amperage using the low amp probe, or high-voltage signals like, secondary ignition.

Example: A signal that normally rises from 0 to +5 volts, if inverted would show falling from 0 to -5 volts.

To turn inversion on/off, select the **Invert** icon.



Invert Icons	
On (Polarity is inverted)	Off (Polarity is not inverted)
	

Coupling AC

Coupling AC subtracts the average value of a signal so that small variations can be displayed in the waveform. This is accomplished by blocking the direct current (DC) portions of a signal in order to amplify (show) the alternating current (AC) portions of the signal, without driving the trace off of the screen.

Using coupling AC can be helpful when testing and diagnosing alternator ripple or fuel pump amperage, by allowing you to see any abnormal small variations or events.

To turn coupling AC on and off, select the **Coupling AC** icon.

Coupling AC Icons	
On (DC signal portion blocked)	Off (DC signal portion not blocked)
	

Trigger



NOTE:

The Trigger feature is only available in the lab scope function.

A trigger can be used to stabilize a changing or erratic signal (a signal that may flicker or drift as it refreshes), so that it is easier to view or diagnose. This stabilization effect is accomplished by basically displaying the same part of the trace repeatedly from the same starting point, thus the flicker or drift is minimized which makes the trace appear more consistent or static.

A trigger is basically a “specific point” on the display, at which a trace will start to display (start the sweep) if it crosses that point.

The trigger feature allows you to set the conditions of that “specific point” also called a “trigger point”. When the trigger conditions are set, and a trace “meets” those conditions (crosses the trigger point), the trace will start.

Trigger conditions:

- **Vertical scale position (amplitude)**
- **Sweep position** - the horizontal scale position, or position in time
- **Slope direction** - the direction the trace must be moving (up/rising or positive) or (down/falling or negative) when crossing the trigger point.

NOTES:



Triggers can be set on any channel, however only one trigger can be activated (used) at a time.

If a trigger is set outside the range of the scales, a yellow marker (e.g. arrow with plus symbol) will be displayed (Figure 10-20) indicating the trigger is out of range and a confirmation screen will display.



When a trigger is set on a channel, and more than one channel is active (displayed), trigger conditions must be met for that channel in order to display all the other channels.



To turn a trigger on/off:

A trigger is activated by selecting the trigger icon from the control panel, which then automatically initiates trigger slope setup.

1. Select the desired channel's **Trigger** icon.
Each tap of the icon sets the trigger to a different slope setting, or turns the trigger off.
2. Select the desired slope setting, to turn the trigger on.

Trigger Icon	Description
	Rising (up or positive) - Trigger is turned on to start the trace on the rising edge (as signal begins to rise)
	Falling (down or negative) - Trigger is turned on to start the trace on the falling edge (as signal begins to fall)
	Off - Trigger is turned off.

3. Proceed to “**To set trigger position**” next to complete the trigger set up.



To set trigger position:

Trigger position (also called trigger level) can be adjusted in two ways:

- Dragging the trigger marker (Figure 10-19) on the touch screen - rough adjustment
- Using the trigger position control panel (Figure 10-19) - fine adjustment

The trigger marker is indicated by a plus symbol (+) on the display (Figure 10-20). The trigger marker represents the trigger point and is displayed on the screen when the trigger is turned on.

To roughly position the trigger marker, select and drag it into position using the touch screen.

4. To more accurately position the trigger marker, select the **Trigger Position Control** icon (Figure 10-20).

The trigger position control panel opens.

5. Use the directional controls provided, or the thumbpad directional controls to move the trigger marker into position (Figure 10-19). Sweep and vertical scale values are provided in the trigger position control panel, which gives you the precise position of the trigger marker.
6. Press the **N/X** button, to exit.

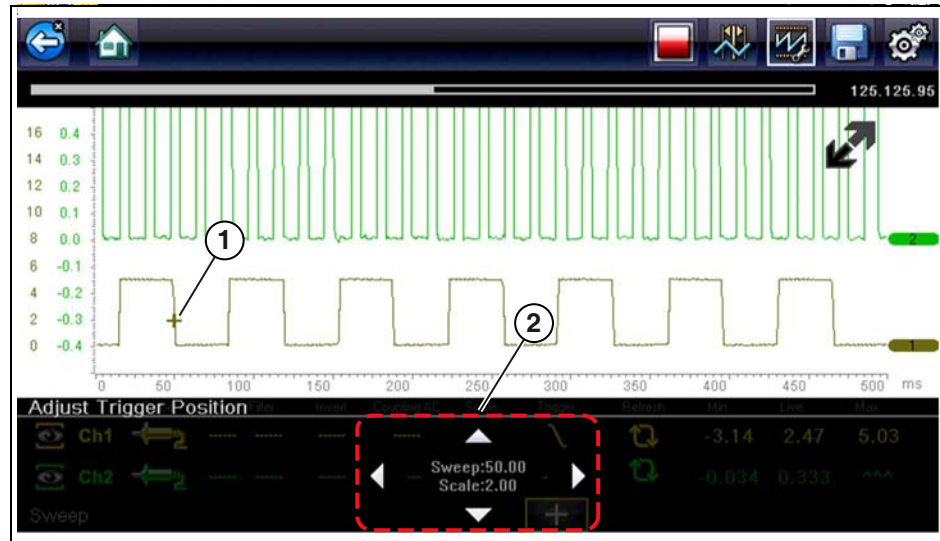

- 1— Trigger Marker
- 2— Trigger Position Control Panel

Figure 10-19 Trigger marker and position controls



- 1— Trigger Marker (out of range symbol)
- 2— Waiting for Trigger Message
- 3— Trigger Position Control Icon

Figure 10-20

Trigger Auto/Manual Mode (Optional Setting)

**NOTE:**

The Auto and Manual Trigger modes allow you to set the criteria used to display signals on the screen. To change the trigger mode, the trigger must be set on one of the channels.

In both Auto and Manual Trigger mode the screen is updated when the signal crosses the trigger point in the selected direction (rising or falling), however:

- **Auto Trigger**—(default mode)
 - when Auto Trigger is on, even if the signal does not cross the trigger point, the screen automatically updates after a short period (allowing you to see the waveform). When this occurs, the message "Waiting for the trigger" (Figure 10-20) is displayed on the screen. The trigger point can then be set to optimize viewing.
 - **Manual Trigger**
 - when Manual Trigger is on, if the signal does not cross the trigger point the screen will not update. This allows you to capture intermittent events, as the screen only updates when the signal meets your trigger selection.
-

**NOTE:**

When using Manual Trigger, it may be easier to initially set the trigger point using Auto Trigger, as the screen will update regardless if the signal crosses the trigger point. Once the trigger point is set, then switch to Manual Trigger mode.

**Selecting Trigger Auto/Manual Mode:**

1. From the Control Panel (on the test meter screen), turn the trigger on for the desired channel.
2. Select the **Settings** icon from the toolbar.
3. Select **Settings > Configure Scope / Meter > Trigger Mode** from the menu selections.
4. Select either **Auto Trigger** or **Manual Trigger**.
5. Select **Back** or press the **N/X** button to navigate back to the test meter screen.

Threshold

**NOTE:**

The Threshold function is only available in the Graphing Meter function for specific tests. This function may also be referred to as Auto Threshold Select (ATS).

The Threshold function can be used, to display and obtain a more accurate measurement when measuring signals (e.g. Frequency, Duty Cycle, MC Dwell and Pulse Width) that may be difficult to display or have noise or other undesirable variations in the signal. When selected, the Threshold function automatically sets a trigger and determines a threshold level in the middle of the signal range (calculated from the Min and Max measurements) to be used as a reference point to calculate the measurement. The falling edge (slope) of the signal is used in determining the threshold level.

To activate the Threshold function, select the **Threshold** icon, then select **Continue** from the confirmation screen (Figure 10-21). Once selected, the Threshold function remains active until the test is exited.

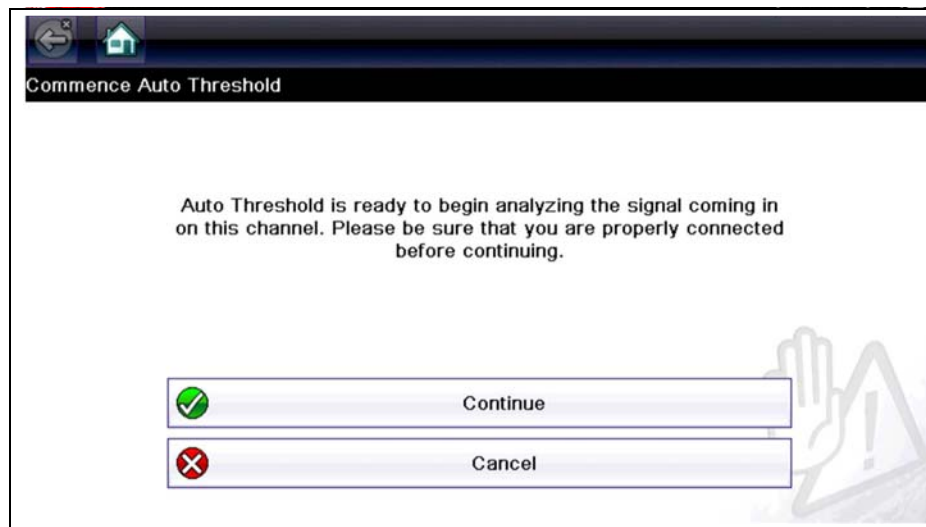

Figure 10-21 Auto Threshold Confirmation Screen

If after enabling the Threshold function, if the signal is still not displayed, reduce the vertical scale setting. Sometimes a low frequency signal may not display if the vertical scale is set too high. If the signal still seems incorrect use the lab scope to verify the signal integrity and signal spacing. Slow or unequal spacing will display as a band or ragged signal, depending on the sweep setting.

Refresh

Selecting the **Refresh** icon (Figure 10-22) clears the active trace(s) displayed and restarts the signal tracking from zero. It also clears the minimum, maximum and live measurements displayed for both channels.

Use the Refresh feature to:

- Track the variation in a component or circuit under a certain condition. If the condition changes, Refresh lets you start tracking again to see the change.
- Verify that a connection problem you found by looking for a dropout or spike in min/max values has been fixed.

Min, Live and Max Display Panel

When Cursors are turned off, the Min, Live and Max display panel (Figure 10-22) is turned on displaying each channel's active signal minimum and maximum recorded measurements and live measurement.

- **Min** - lowest measurement recorded for the signal since the test was activated, or from the last time Refresh was selected
- **Max** - highest measurement recorded for the signal since the test was activated, or from the last time Refresh was selected
- **Live** - represents the "live" running average measurement of the signal being measured

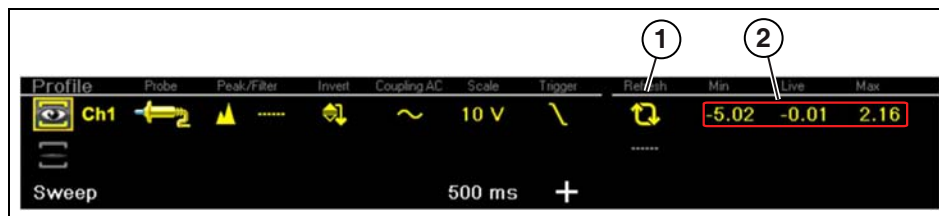

1— Refresh Icon

2— Min, Live, Max Display Panel

Figure 10-22

Cursors



NOTE:

The Cursors feature is only available in the lab scope and Graphing Meter functions.

Two vertical cursors are provided that allow you to make precise signal measurements, when determining signal characteristics such as, amplitude at specific points, and cycle time (duration) or frequency.

Using cursors can also be helpful when performing certain diagnostic tests, such as:

- O2 sensor rich/lean switch time
- fuel injector pulse width frequency
- secondary ignition spark duration
- crankshaft position sensor frequency

Measurements can quickly be taken between the two cursors, when measuring a single cycle or across multiple cycles by positioning the cursors at the start and end of the cycle or multiple cycles.

The cursor measurements panel is displayed when using the cursors, providing you digital values of the cursor measurements. See [Cursor Measurements Panel](#), on page 104 for additional information on the values displayed in the cursor measurements panel.



To turn the cursors on/off:

- To turn the Cursors on (display), select the **Cursor** icon from the toolbar.
Two cursors are displayed on the test screen, and the Refresh, Min, Live, Max display panel is switched off and replaced by the cursor measurements panel. See [Cursor Measurements Panel](#), on page 104 for additional information on the cursor measurements panel.
- To turn the Cursors off, select the **Cursor** icon again from the toolbar.

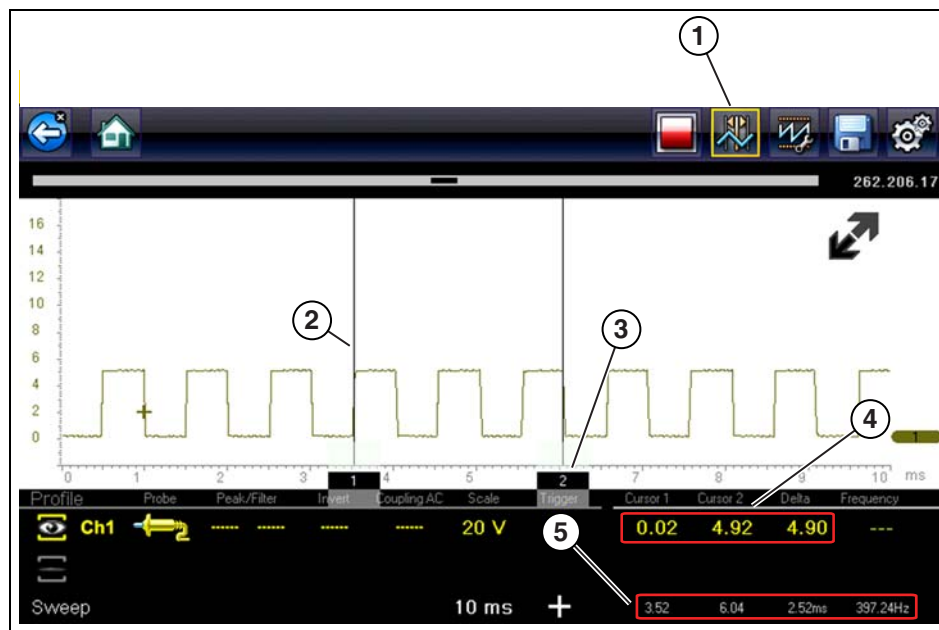

- Cursors Icon
- Cursor (no. 1)
- Cursor Marker (no. 2)
- Cursor Measurement Panel - amplitude and delta display
- Cursor Measurement Panel - time and delta display

Figure 10-23



To position the cursors:

The cursors can be positioned anywhere within the range of the sweep scale ([Figure 10-23](#)).

- Turn the Cursors on.
- Using the touch screen, select either cursor marker (base) and drag it to the desired position.

Cursor Measurements Panel

When the cursors are turned on, the Refresh, Min, Live, Max display panel is switched off and replaced by the Cursor Measurements Panel.

The cursor measurements panel displays the following signal and cursor measurements:

- Signal amplitude at two points
- Signal amplitude difference (delta) between two points
- Cursor position in time at two points
- Difference (delta) in time between the cursors
- Frequency - frequency of the signal for the time period between cursor 1 and 2

The cursor measurements panel contains values for each channel in two displays.

The amplitude and delta display is provided in the channel specific color and includes:

- **Cursor 1** - signal amplitude at cursor 1 position
- **Cursor 2** - signal amplitude at cursor 2 position
- **Delta** - signal amplitude difference between cursor 1 and 2

The time and delta display is gray in color and includes:

- **Cursor 1** - cursor position in time at cursor 1
- **Cursor 2** - cursor position in time at cursor 2
- **Delta** - difference in time between cursor 1 and 2
- **Frequency** - the frequency value (Hz) of the signal for the time period between cursor 1 and 2



NOTE:

Frequency is the number of times a signal repeats itself per second and is measured in hertz (Hz).

The frequency value displayed, is the inverse of the Delta value, and can also be calculated as 1 divided by Delta. The frequency value (Hz) shown is automatically calculated by the scope.

Example 1: Delta = 20.46ms, to get frequency divide 1 by .02046 ($1/.02046 = 48.87\text{Hz}$)

Example 2: Delta = 2.53ms, to get frequency divide 1 by .00253 ($1/.00253 = 395.27\text{Hz}$)

Use applicable decimal point placement during division as the Delta value changes.

10.5.4 Secondary Ignition Testing

The lab scope function can be used to display secondary ignition waveforms for conventional and select CIC and COP systems. To display secondary ignition waveforms, optional secondary ignition coil adapter(s) and a coil adapter lead assembly are required.

Contact your sales representative to purchase the optional adapter leads and/or Secondary Ignition Clip-on or COP/CIC Adapters.

- Adapter lead assembly needed:
 - Secondary Coil Adapter Lead Assembly - connects the diagnostic tool to a secondary ignition adapter (yellow and black scope connectors and black RCA type adapter connector). See [Secondary Ignition Coil Adapter Lead and Clip-on Adapter \(optional\)](#), on page 82.
- Secondary Ignition Adapters available:

Different secondary ignition coil adapters are available as optional equipment. These adapters attach to either the secondary lead (spark plug lead) or directly to the secondary ignition coil in order to pick up the secondary ignition signal.

- Universal kV Ignition Clip-on adapter - clips over a spark plug or coil lead. See [Secondary Ignition Coil Adapter Lead and Clip-on Adapter \(optional\)](#), on page 82.
- Universal stick and flag type adapters - are loosely positioned next to or on a secondary ignition coil.
 - General purpose single flag pick-up.
 - General purpose stick pick-up.
- Vehicle specific Clip-on adapters - are directly attached to (or next to) a secondary ignition coil (COP type) or to a distributor cap (CIC type). Secondary ignition coil-on-plug (COP) and coil-in-cap (CIC) adapters are available for universal and engine specific applications. All the adapters listed are available individually.
 - OEM specific COP adapters:
 - *Ford (COP-1)*
 - *Chrysler (COP-2)*
 - *VW/Audi (COP-3)*
 - *Acura/Honda/Isuzu (COP-4)*
 - *Volvo/BMW (COP-5)*
 - *Mercedes-Benz (COP-6)*
 - *Mercedes-Benz Dual Type (COP-7)*
 - *BMW (COP-8)*
 - *Lexus (COP-9)*
 - *Chrysler/Jeep/Lexus/Toyota (COP-11)*
 - OEM specific CIC adapters:
 - *GM HEI (CIC-1)*
 - *Toyota/Honda (CIC-2)*



Connecting the Secondary Coil Adapter Leads:

1. Connect the black (ground) lead into the diagnostic tool test lead ground jack.
2. Connect the yellow lead into the diagnostic tool test lead channel 1 jack.
3. Connect the adapter lead ground clamp to vehicle ground. If a jumper wire is used to extend the length of the adapter lead ground clamp lead, keep it as short as possible.
4. Connect the adapter lead RCA plug into the secondary ignition "clip-on" or COP/CIC coil adapter as needed.
5. Clamp the secondary clip-on adapter over a spark plug or coil lead, or attach the applicable COP/CIC coil adapter to the vehicle ignition coil.
6. Isolate the leads from other components, to avoid any unwanted noise that could be induced onto the signal.
7. From the lab scope function, select the Ignition Probe (probe setting).
8. If needed, turn the Invert function on.

Once a signal is displayed, further channel settings may be required to display the pattern characteristics you are looking for.

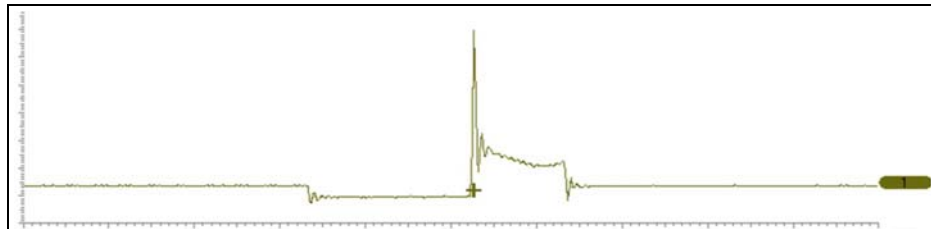

Figure 10-24 Typical Secondary Ignition Signal

10.6 Optional Settings

The following optional Scope/Meter settings are available, and can be set to your preference:

- [Trigger Auto/Manual Mode \(Optional Setting\)](#), on page 100
- [Display \(Grid on/off\)](#), on page 106
- [Divisions](#), on page 107

All optional settings are available from the Tools icon located on the Home screen. Select **Tools > Settings > Configure Scope/Meter** to access the options menu.

10.6.1 Display (Grid on/off)

The Display option allows you to turn the screen grid on/off.

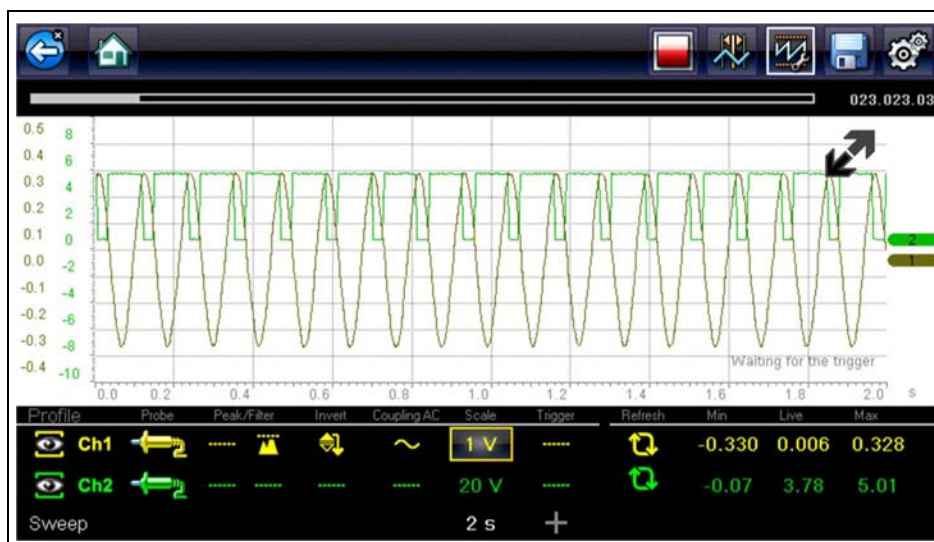

Figure 10-25 Grid on



Changing the Display (grid on/off):

1. Select the **Tools** icon from the Home screen.
2. Select **Settings > Configure Scope/Meter > Display** from the menu options.
3. Select the desired option:
 - **Show Grid**—turns grid lines on
 - **Hide Grid**—turns grid lines off
4. Select the **Back** icon or press the **N/X** button to return to the Settings menu.

10.6.2 Divisions

The Divisions options allow you to change (to your preference) how the Vertical Scale Menu selections are represented, and the type of value that displays in the Vertical Scale icon.

This section describes the following settings:

- **Trace**
 - Trace Full Scale
 - Trace Per Division
- **Display**
 - Display Full Scale
 - Display Per Division

The following illustration is for reference, and identifies key terms and features used in this manual.

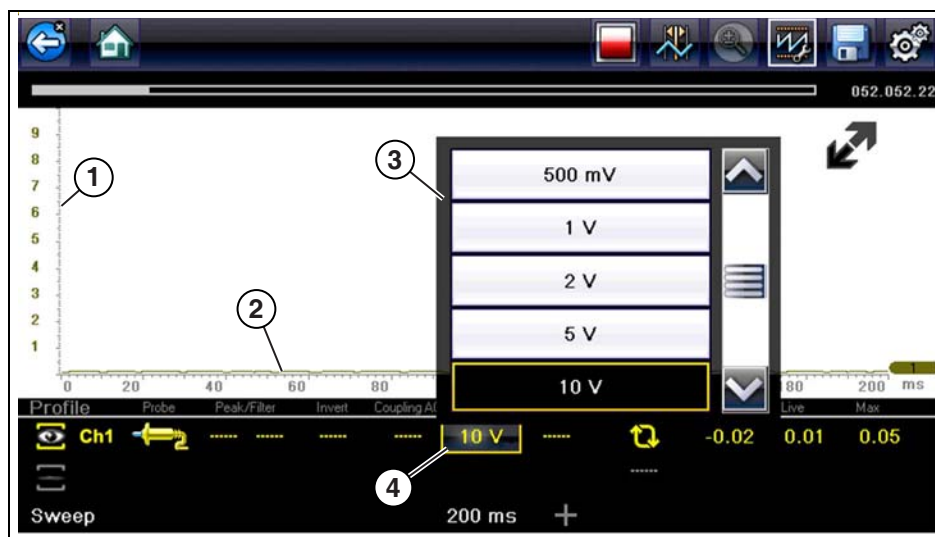

- 1— Vertical Scale
- 2— Sweep (horizontal or time) Scale
- 3— Vertical Scale Menu
- 4— Vertical Scale Icon

Figure 10-26



To access the divisions option menu:

1. Select **Tools** from the Home screen.
2. Select **Settings** from the Tools and Setup menu.
3. Select **Configure Scope/Meter** from the Settings menu.
4. Select **Divisions** from the menu.
5. Select either option:
 - **Trace Settings** - see [Trace Settings](#), on page 108
 - **Display Settings** - see [Display Settings](#), on page 109
6. Select the **Back** icon or press the **N/X** button to return to the Settings menu.

Trace Settings

The Trace Settings option allows you to change how the vertical scale menu selections are represented.



NOTE:

This setting **ONLY** changes the vertical scale, the sweep (horizontal) scale is **NOT** changed.



NOTE:

When adjusting the vertical scale setting, it is important to remember that the vertical scale is divided into 10 major divisions, and all scale adjustments reflect this factor of 10. The division set of 10 cannot be changed, divisions cannot be added or removed.

Trace Full Scale - changes the dropdown vertical scale menu selections to full scale mode, which represents the selected unit of measurement over the entire (full) scale.

Example (Figure 10-27): *Selecting 10V, changes the vertical scale to a 10V volt scale. The vertical scale is “always” divided by 10, therefore each division is incremented by 1V.*

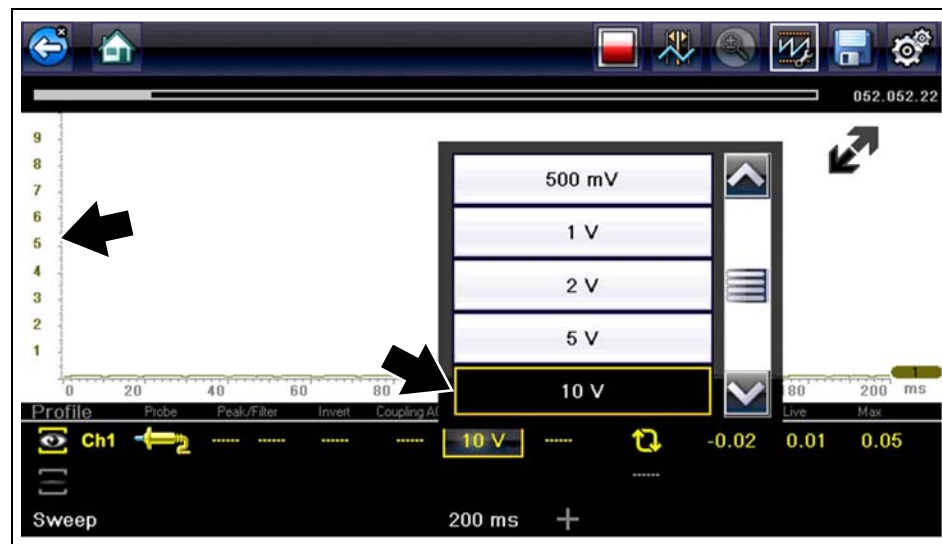

Figure 10-27

Trace Per Division - changes the dropdown vertical scale menu selections to ##/div mode, which in turn changes the vertical scale to represent ## by division.

- represents (variable) what is being measured (voltage, amperage, pressure etc.)

Example (Figure 10-28): Selecting 1.0V/div, displays a vertical scale divided by 10. The vertical scale is “always” divided by 10, therefore each division is incremented by 1.0V, thus a 10V scale.

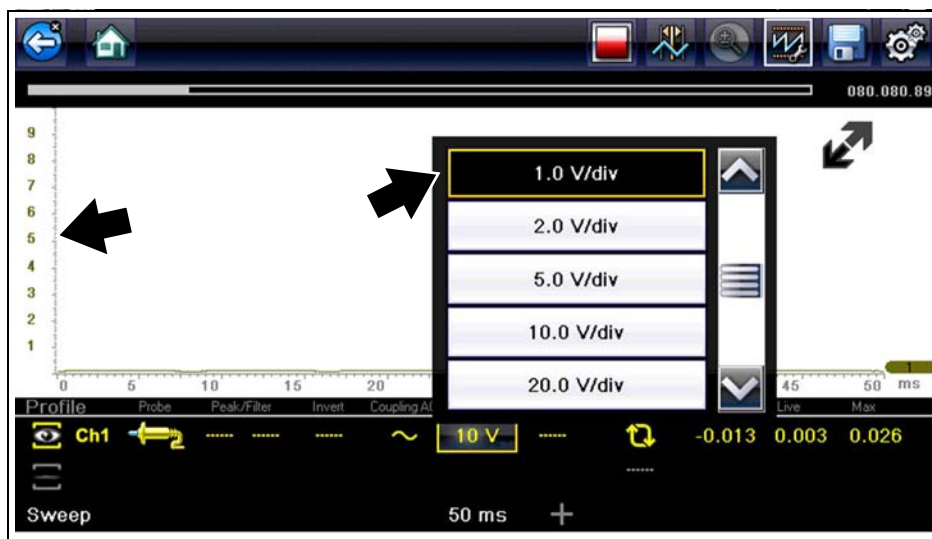

Figure 10-28

Display Settings

The Display setting allows you to change the displayed value in the Vertical Scale icon to your preference.



NOTE:

This setting ONLY changes the value displayed in the Vertical Scale icon.

Display Full Scale - displays the value of the entire (full) scale

Example (Figure 10-29): If the vertical scale is set to 1V, the value displayed is 1V.

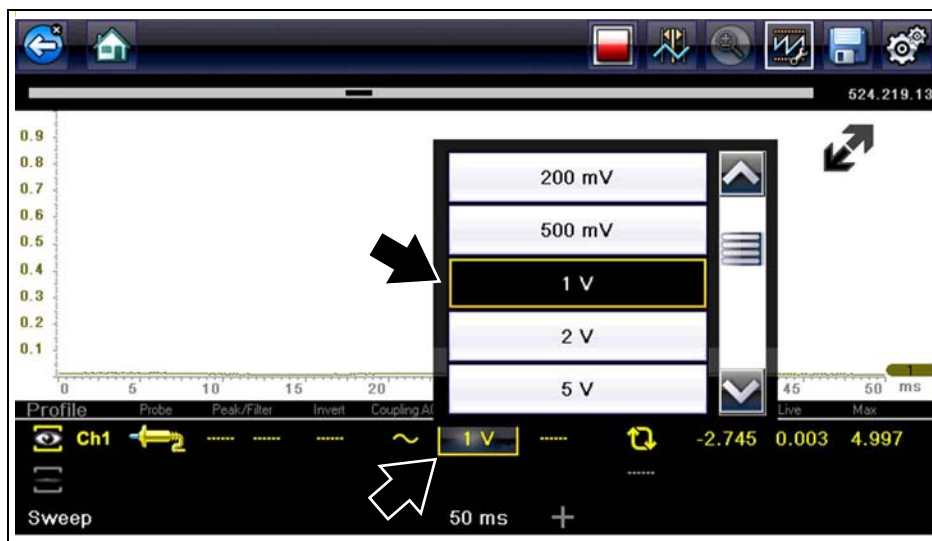

Figure 10-29

Display Per Division - displays the graduation value of the major scale divisions

Example (Figure 10-30): If the vertical scale is set to 1V, the value displayed is 0.1V.

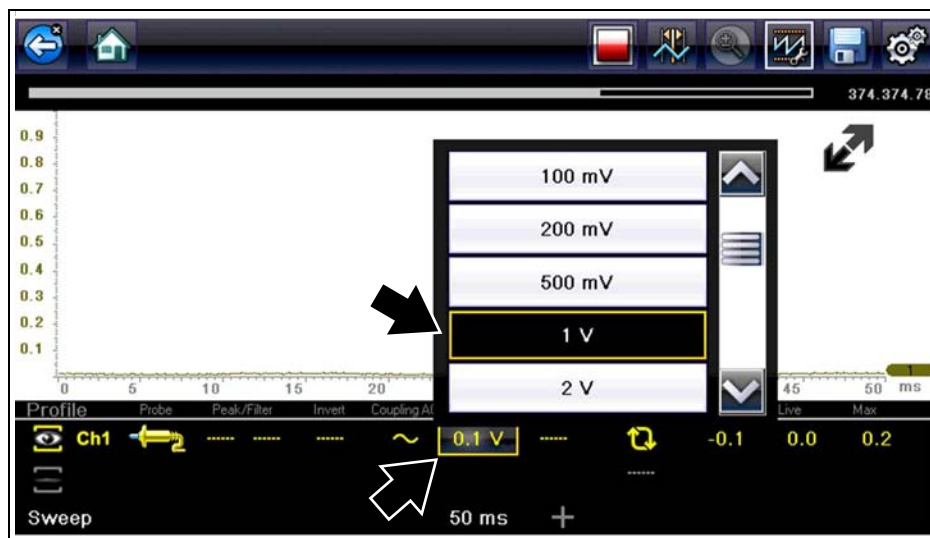

Figure 10-30

10.7 Saving and Reviewing Scope / Multimeter Data Files

The following section describes the procedures used to save and review Scope/Multimeter and Guided Component Tests data files.

10.7.1 Data Buffer

The graphing multimeter and lab scope functions have the capability to save, store and playback, data (test signals) utilizing internal storage memory and buffer memory.

When a test function (e.g. Lab Scope > DC Volts) is selected and displays onscreen, a data buffer automatically starts to store data in buffer memory. The data buffer runs continuously (storing data) until the Stop icon is selected.



NOTE:

The data buffer starts and runs continuously with or without an active input test signal, when a test function is selected.

The Data Buffer Indicator can be used to visually see the amount of stored buffer data. This graphical indicator contains a slider within a bar graph. The bar graph shows how much stored data is in the memory buffer. The slider indicates the position of the current screen in relation to the entire memory buffer contents.

The Data Buffer Position Counter displays a numerical value, indicating the position of the current displayed frame of data within buffer memory.

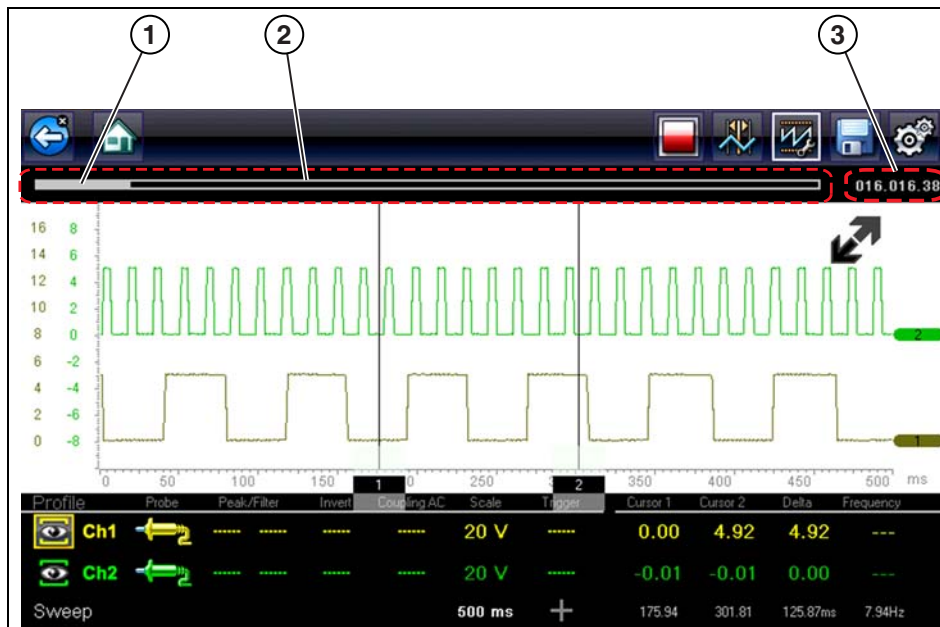

- 1— Data Buffer Indicator Slider
- 2— Data Buffer Indicator Bar Graph
- 3— Data Buffer Position Counter

Figure 10-31

Buffer memory is limited to a predetermined “total” size. When buffer memory reaches its full capacity, the data buffer will continue to store new data, however earlier stored data will be removed to allow room for the new data being stored.

The most recent data is always available for review when the scope is stopped, and can be reviewed using the toolbar controls.

10.7.2 Saving Files

Selecting the **Save** icon writes the data stored in buffer memory to a file. Saving data files is useful when trying to isolate an intermittent problem or to verify a repair during a road test. The saved file can be played back (similar to a movie clip) by selecting **Previous Vehicles and Data > View Saved Data**. See [View Saved Data](#), on page 72 for additional information.



NOTE:

The **Save icon** performs the same function as “Save Movie” function choice for the programmable **Shortcut** button, see [Configure Shortcut Button](#), on page 127 for details.

The saved file can also be downloaded to a personal computer (PC) using the Mini USB jack. Once connected to the PC, the files can be printed, transferred, and copied using ShopStream Connect. ShopStream Connect is a companion application that interfaces the diagnostic tool with a PC. ShopStream Connect is available at no cost, and can be downloaded online. See the ShopStream Connect website information at the front of this manual for additional information.

The toolbar control icons are described in [Scope Multimeter Control Icons](#), on page 85 and [Common Toolbar Control Icons](#), on page 12.

**To save files:**

- Select the **Save** icon from the toolbar.

A save dialog box displays while files are being saved. The file is saved when the message box disappears.

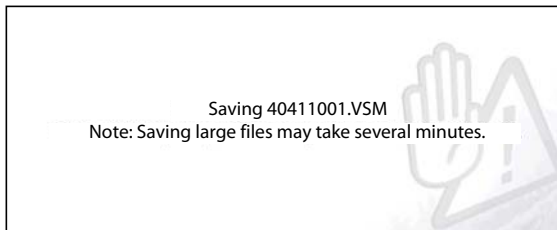

Figure 10-32 Save dialog box

10.7.3 Stopping and Reviewing Data Files

During normal scope multimeter operation, data is continuously being stored in buffer memory as it is displayed onscreen. The Stop feature, allows you to temporarily stop the waveform (signal) to review it in detail.

**NOTE:**

Glitches may cause drivability problems and may not turn on the MIL or set DTCs. As a general guide when looking for a suspected signal glitch, always try to verify the problem by duplicating the conditions while capturing data. Utilize the GMM to monitor the signal over longer time periods and review the histogram for possible faults.

**To stop and review data files**

Playback control icons are described in [Scope Multimeter Control Icons](#), on page 85 and [Common Toolbar Control Icons](#), on page 12.

1. While viewing a waveform (capturing data), select the **Stop** icon.
The playback control icons are displayed.
2. Select the desired playback control icon to step forward or backward through the data.
You can also use the data buffer indicator slider to quickly scroll through the captured data in buffer memory ([Figure 10-33](#)).



1— Skip Back

2— Skip Forward

3— Step Back

4— Step Forward

5— Record

6— Data Buffer Indicator Slider

Figure 10-33



To resume:

- Select the **Record** icon.

The display changes back and the **Stop** icon is shown on the toolbar.



NOTE:

The **Shortcut** button can be set to perform the Pause/Play function. See [Configure Shortcut Button](#), on page 127 for additional information.

10.7.4 Saving Screens

The **Shortcut** button can be programmed to save a snapshot (screen shot) of a visible screen as a bitmap file, see [Configure Shortcut Button](#), on page 127 for details. The saved file can be viewed by selecting **Previous Vehicles and Data > View Saved Data**, see [View Saved Data](#), on page 72 for additional information.

10.7.5 Using the Zoom Function

The zoom function allows you to change the magnification level of the signal sweep during data review. Changing magnification levels allows you to compress or expand multiple screens of data to quickly find glitches, or signal losses.

Example: While monitoring a MAF (Mass Air Flow Sensor) signal, the waveform displays normally. As the signal is being monitored, an erratic "condition" suddenly develops, then goes away, but may have not been observed on the screen. Stopping the data capture (when such an event occurs) allows you to analyze the waveform using a higher zoom level (wider view) to look for a glitch in the signal.

During data capture, the default magnification level is 1x. The zoom function is not available until data capture is stopped by pressing the **Stop** icon (Figure 10-35).

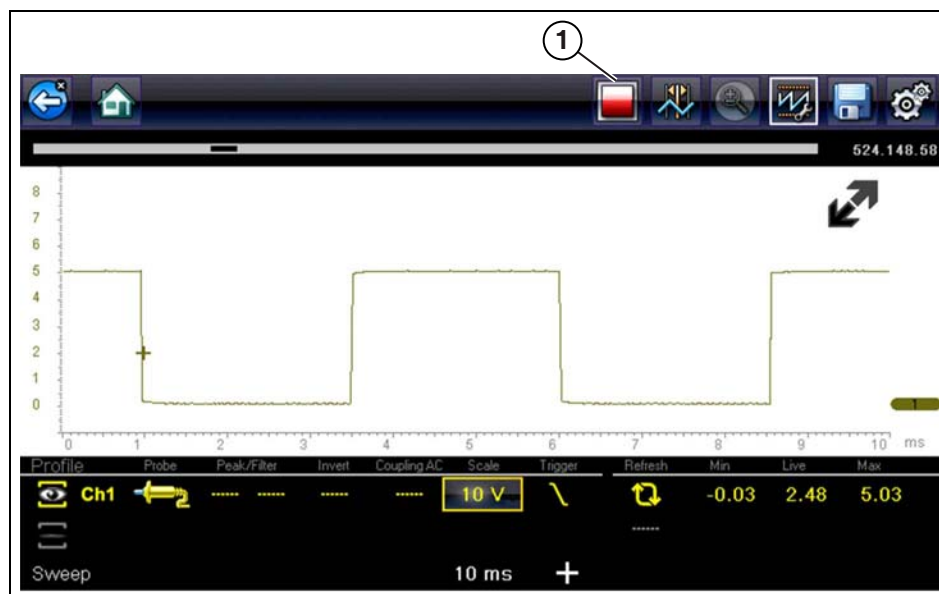

1— Stop Control Icon

Figure 10-34



NOTE:

Zoom playback controls are identical to the standard playback controls used when reviewing data files, with the following exception:

Skip Forward / Skip Back control icons - (press once) moves multiple steps relative to set magnification level (e.g. 2X setting, moves 2 steps; 16X setting, moves 16 steps)

Additional information on playback control icons are described in [Scope Multimeter Control Icons](#), on page 85 and [Common Toolbar Control Icons](#), on page 12.

When the **Zoom** icon is selected the display defaults to the "Max" magnification level and a dropdown scroll menu displays. The dropdown menu allows you to select the display magnification level from a range of 1X to 256X. The "Max" (maximum) option displays all data captured on one screen (Figure 10-35).

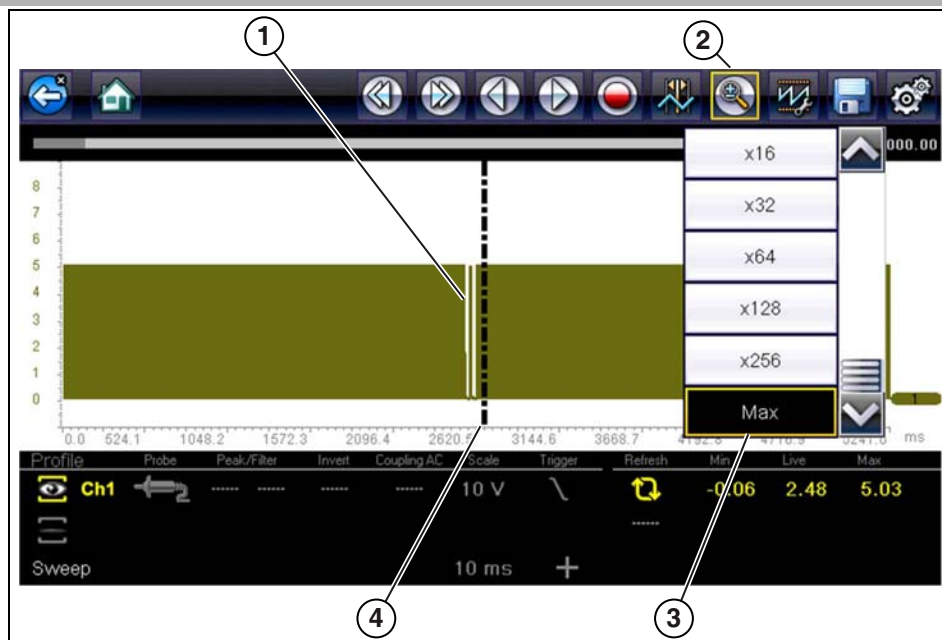

- 1— Waveform Glitches
- 2— Zoom Icon
- 3— Zoom Magnification Level (Max shown)
- 4— Zoom Cursor

Figure 10-35 "Max" Magnification Level - displays all captured data

When zoom levels of 2X and higher are selected, a Zoom cursor (vertical dashed line) (Figure 10-35) displays onscreen. The cursor is used to quickly mark and navigate to points of interest or glitch in a captured waveform.

The Zoom cursor can be used to mark the approximate position of a glitch and can be manually dragged onscreen to the desired position. The new cursor position will be centered on the screen when a lower magnification level is selected. Figure 10-36 shows examples at 32X and 64X with the Zoom cursor positioned in the area of a signal drop glitch.



NOTE:

To quickly identify a glitch in a pattern, it may be easier to initially view the waveform at a higher magnification level (e.g. 256X or "Max") to display the entire captured waveform, then lower the zoom level to 8X or 2X to review in detail.



- 1— Waveform Glitches
- 2— Magnification Level at 128X
- 3— Magnification Level at 32X

Figure 10-36 Examples of Magnification Level at 32X and 128X

Figure 10-37 shows an example at 16X of the same waveform shown in Figure 10-35 and Figure 10-36. In Figure 10-37 at 16X the glitches are easily seen as compared to higher magnification levels.

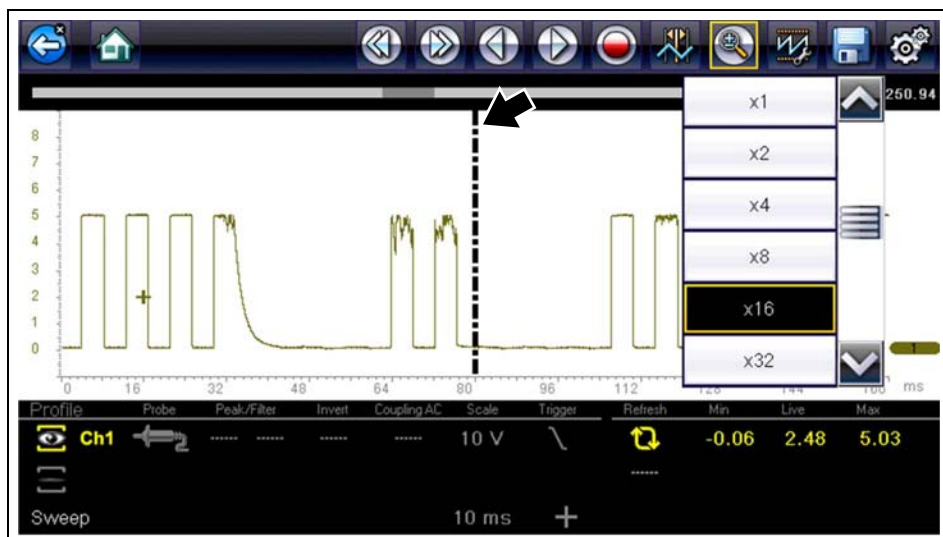

Figure 10-37 Example of Magnification Level at 16X. (For illustration purposes, the Zoom cursor has been positioned in the area near the glitches.)

10.8 General Reference

10.8.1 Basic Setup Tips (unknown signal type)

When conducting automotive diagnostics, situations may arise when you need to capture and analyze a signal that you are not familiar with, or know what the intended waveform pattern should look like, or even how to set the scope to acquire the signal.

The following tips are intended to provide guidance, at the most basic level to assist you in your lab scope diagnostics.

Testing information and/or procedures for testing certain components may be available in the Guided Component Test function, see [Guided Component Tests](#), on page 61 for additional information. If you have already narrowed down the system and/or component to test, ID the vehicle within the Guided Component Test function, and check the available tests first, as this may save you some time.

If the Guided Component Test function, does not have the test you are looking for, you need to determine a few things about what you are testing to get the scope / meter set up to capture a signal or make a measurement.



NOTE:

Testing information and known good waveform libraries may also be available from online sources. Obtaining correct testing reference information can be a key advantage in making sound repair decisions.

Listed below are a few basic questions to help narrow down the testing direction to follow.

- Are you looking to make or test a simple voltage or current level or maybe check resistance or continuity? Then you may want to use the DMM.
- Are you looking to check a circuit/component for an erratic dropout or make a frequency test? You may want to use the GMM.
- Do you need to see signal details (level, shape, frequency etc.)? The lab scope may be the best choice.
- Are you testing a DC or AC signal?
- What is the operating range of the circuit?
- Do you know what type or shape the intended waveform should be?

After answering the questions above (at a minimum), you need to determine which Scope / Multimeter test function you are going to use (e.g. Lab Scope, DMM or GMM). See [Tests and Capabilities \(Quick Reference\)](#), on page 79.

Once your test function is selected, you can now connect the test leads and select the applicable probe and scales:

Probe (test) type, see [Probe \(Probe type “test” selection\)](#), on page 93

Vertical scale, see [Scale \(Vertical scale adjustment\)](#), on page 90

Sweep scale, see [Sweep \(Horizontal or Time scale adjustment\)](#), on page 91

Connect the test leads or probe, to the applicable test point(s). Always use the correct lead or probe designed for the test and ensure the signal and ground connections are clean and secure.

For the initial setup, you may wish to turn other channel settings off (e.g. Peak, Filter, Invert, AC Coupling, Threshold etc.), as these may affect the signal display. See [Channel Settings](#), on page 94.

As a default setting, trigger is normally off. The scope/meter uses internal circuitry to display a signal if present. However, in certain circumstances additional channel adjustments may be required, or the trigger mode may have to be turned on, for a signal that is present but is not displayed. You may also need to readjust the vertical scale if set to low, in order to bring the signal into the viewable display area.

At this point you should have a visible signal on the screen. An ideal signal should be displayed within the area of the display.

- If the signal goes beyond the top and bottom of the display, try and readjust the vertical scale to a higher setting, to bring the signal into the viewable display area.

Use the zero baseline controls or move the zero baseline marker onscreen to move the zero baseline of the signal vertically on the screen to the desired position. See [Trace \(Zero Baseline position adjustment\)](#), on page 95.

- If the signal cycles are compressed (close to each other), try and readjust the sweep scale (horizontal scale) to a lower setting to display less cycles.

Once you have a usable signal displayed, if needed use the trigger function to stabilize a changing or erratic signal (a signal that may flicker or drift), so that it is easier to view. Try and set the trigger at the mid-point of the signal, and then adjust as needed from there. See [Trigger](#), on page 97.

As all signals are different, and due to other variables, additional adjustments may be needed to get the signal displayed exactly how you need. Review the channel settings section in this manual for additional information on using the settings. See [Channel Settings](#), on page 94.

At this point you should have a signal displayed that will allow you to see the overall signal characteristics, and allow you to begin your diagnosis.

Comparing your captured waveforms to known good waveforms, can be a time saver and provide supporting evidence when trying to determine a fault. See [Using Known Good Waveforms](#), on page 118 for additional information.

10.8.2 Using Known Good Waveforms

In some cases captured waveforms may not provide enough information to determine if a suspected sensor or circuit is at fault. Comparing the test vehicle waveforms to known good waveforms, can help to provide supporting evidence when trying to determine a fault.

Known good waveform examples may be available from different sources including the Guided Component Tests function, and online information sources.

As good practice, capturing waveforms before and after the repair will help you to build your own library of waveforms for future troubleshooting.

10.8.3 Troubleshooting Signals

When capturing signals, you may occasionally encounter problems with the way the signal initially displays. Noise, hash, fuzz are some of the terms used to describe, unwanted signals displaying in or on the signal you are trying to capture, basically making the signal unclear. The following tips are intended to provide some basic guidance, to help resolve these types of issues if encountered.

- Make sure you have the correct test leads connected to the applicable test point(s) and test lead jacks on the diagnostic tool.
- Ensure the signal and ground connections are clean and secure, at the test points and diagnostic tool.
- Ensure the polarity of the test leads connections are correct.
- If using stackable connectors, try to isolate or only connect the leads being used to capture the signal.
- Make sure the ground lead is providing a direct ground from the circuit to the diagnostic tool test lead jack.
- Isolate the test leads from other components, leads, or systems that may induce unwanted noise into the signal being tested (e.g. electric motors, secondary ignition components, relays, alternators, etc.)
- Use the shortest test leads possible.
- Try different test leads, to verify the issue. Use the recommended snap-on leads or probes available for the diagnostic tool or equivalent. Shielded test leads are recommended.
- Check the test lead or probes for damage.
- Enable or disable channel controls also to help try and clean the signal:
 - [Peak Detect](#)—maximizes sampling rate, but may pickup unwanted noise
 - [Filter](#)—removes signal noise or interference
 - [Invert](#)—switches signal polarity
 - [Coupling AC](#)—blocks the DC portion of signal
 - [Threshold](#)—provides a more accurate measurement on select GMM tests where noise is present
 - [Scale \(Vertical scale adjustment\)](#)—adjusts vertical scale. Using a higher setting may provide a cleaner signal in some situations.

For signals that do not display or display off the screen, erratic, compressed etc.:

- Use a trigger to help stabilize the signal. Try and set the trigger at the mid-point of the signal, and then adjust as needed from there. See [Trigger](#), on page 97.
- If the signal wraps off the top and bottom of the display, try and readjust the vertical scale to a higher setting, to bring the signal into the viewable display area. See [Scale \(Vertical scale adjustment\)](#).
- If the signal cycles are compressed (close to each other), try and readjust the sweep scale (horizontal scale) to a lower setting to display less cycles. Try a higher setting if the cycles are spread too far across the screen and seem flat. See [Sweep \(Horizontal or Time scale adjustment\)](#), on page 91.
- Move the zero baseline marker to move the zero baseline of the signal vertically on the screen to the desired position. See [Trace \(Zero Baseline position adjustment\)](#), on page 95.
- Check calibration of test leads or probe(s) if applicable. See [Test Lead / Probe Calibration](#), on page 88.

10.8.4 Units of Measurement / Conversions

Base Units	
(Symbol) / Unit Prefix	Typical Expressions
(μ) micro	0.000001 or 10^{-6} or 1/1,000,000
(m) milli	0.001 or 10^{-3} or 1/1,000
(c) centi	0.01 or 10^{-2} or 1/100
(k) kilo	10^3 or 1,000
(M) mega	10^6 or 1,000,000

Electrical Units	
(Symbol) / Description	Equivalents
(V) Voltage	$V = I \times R$
(I) Current	$I = V \div R$
(R) or (Ω) Resistance	$R = V \div I$
(Hz) Frequency	$f(\text{freq.}) = 1 \div T(\text{time})$ or 1 cycle per second
Voltage	
(μ V) microvolt	1 μ V = 0.000001 V
(mV) millivolt	1 mV = 0.001 V
(V) volt	1 V = 1000 mV
(kV) kilovolt	1kV = 1,000 Volts.
Ohms	
(m Ω) milliohm	1 m Ω = 0.001 ohms
(Ω) ohm	1 Ω = 1000 m Ω
(k Ω) kilohm	1 k Ω = 1000 Ω
(M Ω) megaohm	1 M Ω = 1,000,000 Ω
Amperes	
(μ A) microamps	1 μ A = 0.000001 amps
(mA) milliamps	1 mA = 0.001 amps
(A) amps	1A = 1000 mA
(ka) kiloamps	1 ka = 1000 amps
Frequency	
(MHz) megahertz	1 MHz = 1,000,000 Hertz
(kHz) kilohertz	1 kHz = 1000 Hertz

Pressure Units	
(Symbol) / Description	Equivalents
(psi) pounds per square inch	1 psi = 6894.757 Pa 1 psi = 0.06894757 bar 1 psi = 2.036021 inHg
(bar)	1 bar = 14.50377 psi 1 bar = 100000 Pa 1 bar = 29.52999 inHg
(Mbar) Millibar	1 Mbar = 0.001 bar
(Pa) pascal	1 Pa = 0.0001450377 psi 1 Pa = 0.00001 bar 1 Pa = 0.0002952999 inHg

Pressure Units	
(Symbol) / Description	Equivalents
(kPa) KiloPasca	1 kPa = 1000 Pa
(MPa) Megapascal	1 MPa = 1,000,000 Pa
(inHg) inches of mercury	1 inHg = 0.03386388 bar 1 inHg = 0.4911541 psi 1 inHg = 3386.388 Pa

Pressure Conversions
psi x 0.0689 = bar
psi x 6.8950 = kPa
psi x 0.0703 = kg/cm ²
bar x 14.5030 = psi
bar x 100.0000 = kPa
bar x 29.5300 = inHg (60°F)
kPa x 0.1450 = psi
kPa x 0.0100 = bar
kPa x 0.0102 = kg/cm ²
kPa x 0.295299 = inHg
kg/cm ² x 98.0700 = psi
kg/cm ² x 0.9807 = bar
kg/cm ² x 14.2200 = kPa
inHg (60°) x 0.0333 = bar
inHg (60°) x 3.3770 = kPa
inHg (60°) x 0.0344 = kg/cm ²
inHg x 25.4 = mmHg
mmHg x 0.003994 = inHg

Temperature Units	
(Symbol) / Description	Conversions
(°C) degree Celsius	°C = 0.556 x (°F - 32)
(°F) degree Fahrenheit	°F = (1.8 x °C) + 32

Time Units	
(Symbol) / Description	Equivalents
(μs) microsecond	1 μs = 0.000001 of a second
(ms) millisecond	1 ms = 0.001 of a second
(s) second	1 s = 1000 ms

Duty % to Dwell Conversions			
Duty Cycle	Dwell		
	4 cyl	6 cyl	8 cyl
%			
10	9.0	6.0	4.5
20	18.0	12.0	9.0
30	27.0	18.0	13.5

Duty % to Dwell Conversions			
Duty Cycle	Dwell		
%	4 cyl	6 cyl	8 cyl
40	36.0	24.0	18.0
50	45.0	30.0	22.5
60	54.0	36.0	27.0
70	63.0	42.0	31.5
80	72.0	48.0	36.0
90	81.0	54.0	40.5
100	90.0	60.0	45.0

10.8.5 Glossary of Common Terms

Term / Abbreviation	Description
AC	Alternating Current - electrical current that switches polarity at regular intervals.
Aliasing	An effect that causes an incorrect signal to be displayed and/or causes a trigger to malfunction, due to the input signal exceeding the sample rate of the scope.
Amperage	The strength of an electric current, expressed in amperes
Amplitude	Vertical magnitude (level or position) of a signal, or the varying quantity from its zero value.
Buffer	An electronic reservoir for temporary storage of data
Cursor	Onscreen markers used to measure time, amplitude and frequency
Coupling AC	Function used to subtract the average value of a signal so that small variations can be displayed in the waveform.
DC	Direct Current - electrical current that flows in one direction only
Delta	Difference in time between two events.
Dropout	An intermittent or unwanted, vertical fall in a signal to zero that may cause an undesired result.
Duty cycle	Measurement of the length of a signals on time. Specified as a percentage (ratio), of the total cycle time.
Dwell	Used to measure a signals on time in degrees of dwell. Commonly used to measure mixture control solenoids on carbureted feedback engines and specified in duty cycle %.
Dwell 60	Measurement of the length of a signals on time displayed on a 0 to 60 degree scale. 0° = 0%; 30° = 50%; 60° = 100%.
Dwell 90	Measurement of the length of a signals on time displayed on a 0 to 90 degree scale. 0° = 0%; 45° = 50%; 90° = 100%.
Filter	Function used to filter or smooth out spikes and fast variations in signals.
Frequency	The number of times a signal repeats in one second. Measured in Hertz (cycles per second).
Glitch	An intermittent or unwanted, error in a signal that may cause a false or undesired result.
Grid	The graph displayed on the scope screen that is made up of the x and y axis scales that aid in the measuring of signal characteristics.

Term / Abbreviation	Description
Horizontal Scale	See Sweep Scale
Invert	Function used to switch signal polarity,
Lambda (l)	Used to represent a numerical value denoting the actual measured air/fuel ratio with respect to the ideal air/fuel ratio at stoichiometry. Lambda equals one (1) when the actual air/fuel ratio is equal to the theoretical (stoichiometric) air/fuel ratio of 14.7 (14.66) to 1. Lambda less than 1 means excess fuel; greater than 1 means excess air.
Megasamples per second (MS/s)	Sample rate unit equal to one million samples per second
Noise or Hash	Unwanted voltage, current or signal interference that is imposed on a signal.
Parasitic Voltage	Trace voltage in a circuit after the main power source is disconnected.
Peak	The maximum amplitude value present in a varying or alternating voltage. This value may be either positive or negative.
Peak Detect	Peak detect captures and evaluates all signal sample points, in order to display fast occurring events or glitches.
Pressure Transducer	Electronic device that converts pressures (negative/positive) to electrical signals.
Pulse	A signal with abrupt (fast) signal direction changes in a positive or negative direction, with consistent level and duration.
Pulse Period	One complete on and off cycle or time period.
Pulse Train	Collection of signal pulses traveling together.
Pulse Width (duration)	Measurement of a signals on time in a circuit that pulses on and off. Specified in units of time.
Pulse Width Modulation (PWM)	A signal that continuously cycles on and off while the on-time varies within each cycle.
RMS	The RMS (root mean square) value of alternating currents and voltages is the effective current or voltage applied, rather than the peak current or voltage measurable. The AC RMS voltage value can be defined as the equivalent DC voltage of the AC voltage measured. RMS values are commonly used in AC electrical measurement, as they are more representative of DC measurements.
Sample Rate	Number of times (frequency) the scope/meter takes a sample of the signal. Specified in mega samples per second (MS/s).
Sampling	Process of obtaining a sequence of instantaneous values for a signal at regular or intermittent intervals. When a quantity of samples are collected the operational status of the device is determined.
Screen Update Rate	How often the captured data is (updated) displayed on the screen.
Signal	Detectable voltage, current, or magnetic field, by which specific information is transmitted in an electronic circuit or system.
Square Wave	A square or rectangular waveform (digital) which alternately switches high to low (on/off) for specific lengths of time, that has very fast rise and fall times.
Sweep Scale	The horizontal scale on the grid. Also referred to as time scale or x axis.

Term / Abbreviation	Description
Threshold	The threshold function automatically sets a trigger and determines a threshold level in the middle of the signal range (calculated from the Min and Max measurements) to be used as a reference point to calculate the measurement.
Trace	The actual visible line displayed on the scope screen.
Trigger	A conditional function that initiates if and when a trace is drawn on the screen.
Trigger Slope	The slope that a trigger source signal must reach before the trigger circuit initiates a sweep
VAC	Volts Alternating Current
VDC	Volts Direct Current
Vertical Scale	The vertical scale on the grid or (y-axis) represents what is being measured (voltage, amperage, pressure etc.), and the unit of measurement it is being measured in.
Volt	Unit of electric potential difference.
Voltage	Electromotive force or potential difference, expressed in volts.
Voltage (inductive) Kick	A voltage, many times higher than the applied voltage, produced by the collapsing magnetic field in a coil when the current through it is abruptly terminated.
Waveform	The graphic representation (form) of a signal over time, which the trace displays on the screen.
Zero Base Line	Reference setting or 0% level of a graph scale.

This chapter describes the basic operation of the Tools function.



The **Tools** icon is located on the Home screen. This function allows you to configure Diagnostic Tool settings to your preferences.

11.1 Tools Menu

The following options are available from the Tools menu:

- [Connect-to-PC](#)—use to transfer and share files with a personal computer (PC)
- [Configure Shortcut Button](#), on page 127—use to change the function of the shortcut button
- [System Information](#), on page 127—use to view configuration information for the Diagnostic Tool
- [Settings](#), on page 128—use to configure certain characteristics of the Diagnostic Tool

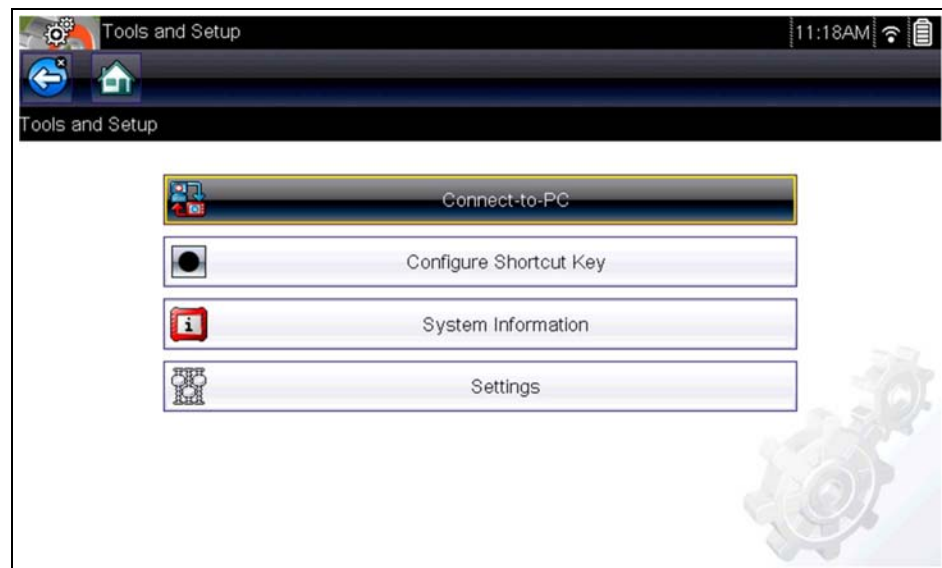

Figure 11-1 Tools menu

11.1.1 Connect-to-PC

Connect-to-PC allows you to transfer saved data files on your diagnostic tool to your personal computer using a USB cable.

The optional ShopStream Connect™ PC software allows you to view, print and save data files on your PC. In addition, you can download software updates from the PC to the diagnostic tool. These features provide an ideal way to manage saved data files. The ShopStream Connect application is available free online, see [ShopStream Connect](#), on page 164 for additional information.



To connect the diagnostic tool to a PC:

1. Connect the supplied USB cable to the diagnostic tool and then to the PC.
A USB cable, supplied with your diagnostic tool, is used to connect the diagnostic tool to the PC. When the diagnostic tool is connected to the PC a communications icon appears on the right edge of the title bar.
2. Select **Tools** from the Home screen.
3. Select **Connect-to-PC** from the Tools and Setup menu.

A screen message will display to confirm the tool is in Connect-to-PC-mode.



This device is now in Connect-to-PC mode.

Press  to exit.



Figure 11-2

11.1.2 Configure Shortcut Button

This feature allows you to change the function of the **Shortcut** button. Options are:

- **Brightness**—opens the brightness setting screen.
- **Save Screen**—saves a bitmap image of the visible screen.
- **Save Movie**—writes PID data from buffer memory to a file for future playback.
- **Show Shortcut Menu**—opens the menu so you can quickly select from any of the functions.
- **Toggle Record/Pause**—programs the Shortcut button to work as the Pause and Play icons.



To assign a function to the Shortcut button:

1. Select **Tools** from the Home screen.
The Tools menu opens.
2. Select **Configure Shortcut button** from the menu.
3. Select a function from the menu.
4. Select the **Back** on the toolbar or press the **N/X** button to return to the options menu.

11.1.3 System Information

System Information allows you to view patent information and system information such as the software version and serial number of your Diagnostic Tool.



Figure 11-3 System information



To display the System information screen:

1. Select **Tools** from the Home screen to open the menu.
2. Select **System Information** from the menu.
The System Information screen displays.
3. Scroll as needed to view all of the data.
4. Select **Back** on the toolbar or press the **N/X** button to return to the options menu.

11.1.4 Settings

This Tools selection allows you to adjust certain basic Diagnostic Tool functions to your personal preferences. Selecting opens an additional menu that offers the following:

- System Settings - see [System Settings](#), on page 128
- Configure Wi-Fi - see [Configure Wi-Fi](#), on page 133
- Configure Scanner - see [Configuring Scanner](#), on page 133
- Configure Units - see [Configure Units](#), on page 135

System Settings

Selecting System Settings opens a menu with two options; Display and Date & Time. Either selection opens an additional menu.

Display options include:

- [Brightness](#), on page 129—adjusts the intensity of the screen back lighting.
- [Color Theme](#), on page 129—changes the background color of the screen display.
- [High Contrast Toolbar](#), on page 130—enhances toolbar graphics for poor lighting conditions.
- [Font Type](#), on page 130—switches between standard and bold text for better visibility.
- [Backlight Time](#), on page 131—adjusts how long the screen stays on with an idle Diagnostic Tool.
- [Touch Screen Calibration](#), on page 131—calibrates the touch screen display.

Date & Time options include:

- [Time Zone](#), on page 132—sets the internal clock to the local time standard.
- [Clock Settings](#), on page 132—sets the time on the internal clock.
- [Daylight Savings Time](#), on page 133—configures the clock for Daylight Savings Time.
- [Time Format](#), on page 133—switches the time displays between a 12 or 24 hour clock.
- [Date Format](#), on page 133—configures how the month, date, and year displays.

Auto VIN

- [Time Zone](#), on page 132—sets the internal clock to the local time standard.
- [Clock Settings](#), on page 132—sets the time on the internal clock.
- [Daylight Savings Time](#), on page 133—configures the clock for Daylight Savings Time.
- [Time Format](#), on page 133—switches the time displays between a 12 or 24 hour clock.
- [Date Format](#), on page 133—configures how the month, date, and year displays.

Brightness

Selecting this option opens the brightness setting screen for adjusting the back lighting of the display (Figure 11-4).

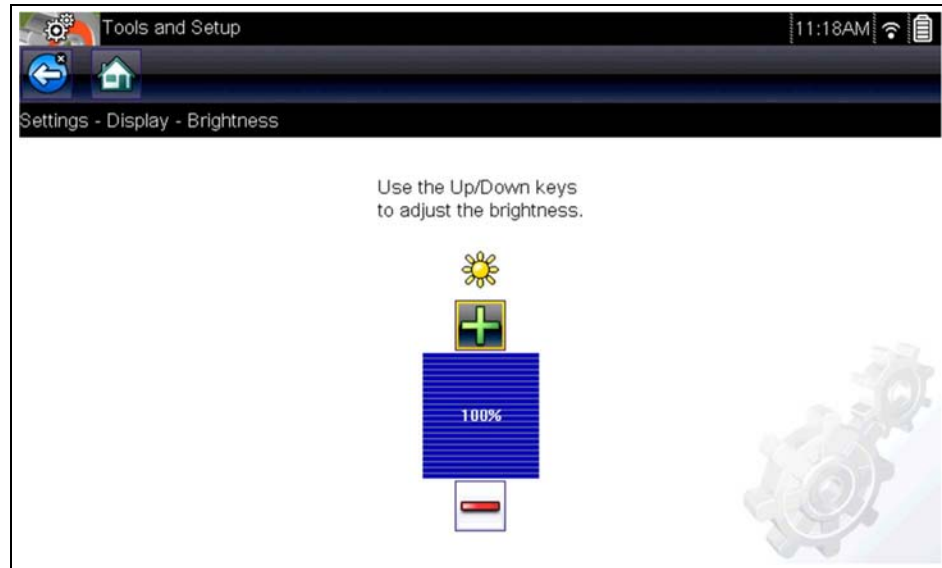

Figure 11-4 Brightness setting

Each push of the **Plus** and **Minus** icons, or the up (▲) and down (▼) arrows, incrementally changes the back lighting up or down respectively.

Select **Back** from the toolbar or press the **N/X** button to exit.

Color Theme

This option allows you to select between a white and black background for the screen. The black background can be beneficial when working under poor lighting conditions.

Selecting opens a menu with two choices: **Day Theme** (white background) and **Night Theme** (black background). Make a selection and a "please wait" message momentarily displays followed by the Home screen. The new toolbar setting is now active.

High Contrast Toolbar

This option allows you to switch to a high contrast toolbar. This toolbar features black and white icons with crisp graphics that are easier to see in poor lighting conditions or bright sunlight.

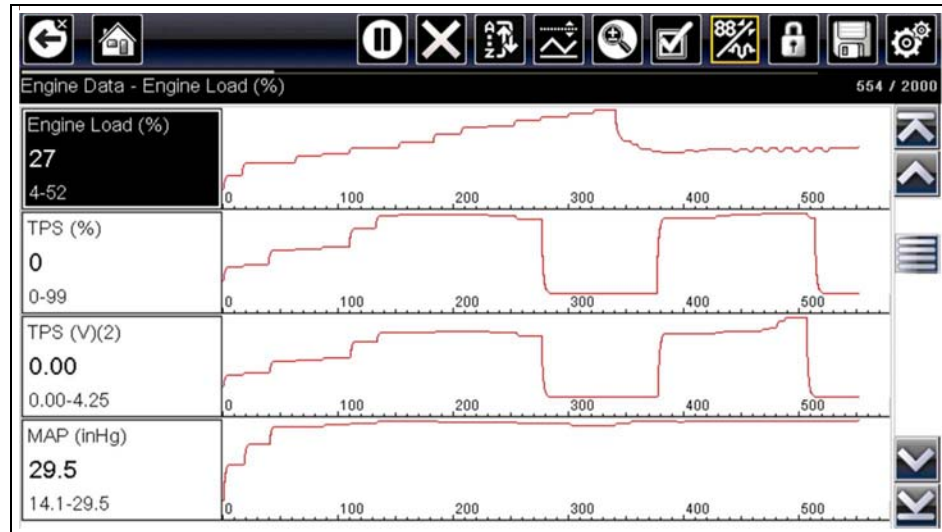

Figure 11-5 High-contrast toolbar

Selecting opens a menu with two choices; Color Toolbar and High Contrast Toolbar. Select and a "please wait" message displays followed by the Home screen. The new setting is now active.

Font Type

This option allows you to select between standard and bold faced type for the display screen. Bold type makes screen writing more legible under poor lighting or bright sunlight conditions.

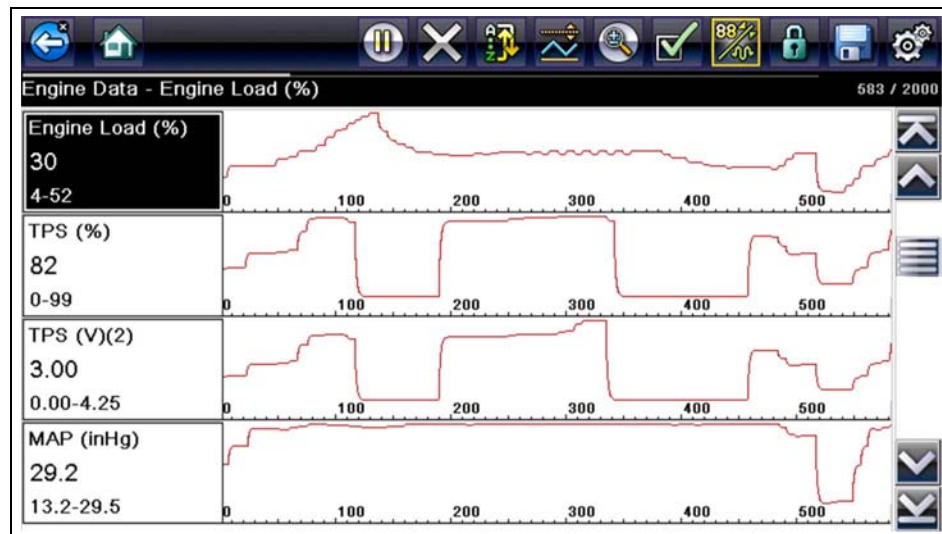

Figure 11-6 Bold type on a black background

Selecting opens a menu with two choices: Normal Font and Bold Font. Select a menu item or scroll and then press the **Y/✓** button to make a selection. The change is instantaneous. Select the Back or Home icon on the toolbar to return to either the Settings menu or the Home screen.

Backlight Time

This option allows you to configure how long the screen backlight remains on when the Diagnostic Tool is inactive. The following choices are available:

- Always On
- 15 Seconds
- 30 Seconds
- 45 Seconds
- 60 Seconds

Select the menu item desired, or scroll and then press the **Y/✓** button to make a selection. Select **Back** or **Home** on the toolbar to return to either the Settings menu or the Home screen.

Touch Screen Calibration

Calibrating the touch screen maintains the accuracy of the touch-sensitive display.

IMPORTANT:

To avoid serious damage to the Diagnostic Tool, always complete the touch screen calibration sequence once it has begun. **Never turn off the Diagnostic Tool while a screen calibration is in process.**



To calibrate the touch screen:

1. Select **Tools** from the Home screen to open the menu.
2. Select **Settings** from the menu.
3. Select **Touch Calibration** from the menu.

The calibration screen opens ([Figure 11-7](#)).



Figure 11-7 Touch screen calibration

4. Select each box on the screen as it displays.
The display returns to the Settings menu once the screen calibration procedure is complete.

Time Zone

This option opens a menu of time zone settings. Scroll to highlight, then select the local time zone. The display returns to the Settings menu once a time zone is selected.

Clock Settings

This option opens a window for resetting the time on the real-time clock.



To set the clock:

1. Select **TOOLS** from the Home screen to open the menu.
2. Select **Settings** from the menu.
3. Select **Clock Settings** from the menu.

A warning message briefly displays followed by the Clock Settings screen ([Figure 11-8](#)).



Figure 11-8 *Clock settings*

4. Select the **up (+)** icon on the screen or press the **up (▲)** button to incrementally increase the number in the highlighted field. Select the **down (-)** icon on the screen or press the **down (▼)** button to incrementally decrease the number.
5. Select the **check (✓)** icon on the screen or press the **Y/✓** button to move the highlight to the next field.
6. Repeat Step 4 and Step 5 until the correct time is displayed.
7. Select the **Back** icon on the toolbar or press the **N/X** button to close the Clock Settings window and return to the Settings menu.

Daylight Savings Time

This option opens a menu to configure the internal clock for Daylight Savings Time. Choose from:

- **ON**—sets the clock for Daylight Savings time.
- **OFF**—sets the clock for standard time.

Make either selection, then select the **Back** icon or press the **N/X** button to return to the menu.

Time Format

This option determines whether time is displayed on a 12 or 24 hour clock. Selecting opens a menu with two choices:

- **24 Hour Format**
- **12 Hour Format**

Make either selection, then select the **Back** icon or press the **N/X** button to return to the menu.

Date Format

This option allows you to select how date information is displayed. Select from:

- **(MM_DD_YYYY)**—Month, Day, Year
- **(DD_MM_YYYY)**—Day, Month, Year
- **(YYYY_MM_DD)**—Year, Month, Day

Make a selection, then select the **Back** icon or press the **N/X** button to return to the menu.

Configure Wi-Fi

See [Wi-Fi Connection / Troubleshooting](#), on page 156.

Configuring Scanner

This option allows you to change the scanner display to toggle scales on and off. Scales are the graduations and values that display on the horizontal axis at the base of the parameter graphs. The waveform fills the entire graph area with scales switched off.

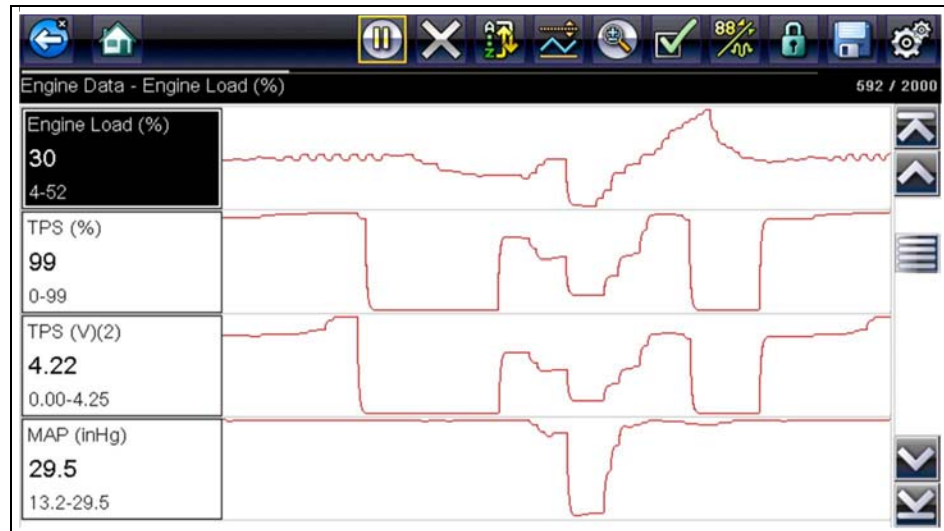

Figure 11-9 Scales hidden



To change hide/show scales:

1. Select **Tools** from the Home screen.
2. Select **Settings** from the Tools and Setup menu.
3. Select **Configure Scanner** from the Settings menu.
4. Highlight either menu entry to make a selection:
 - **Show Graph Scale**—to switch the scales on.
 - **Hide Graph Scale**—to switch the scales off.
5. Select the **Back** icon or press the **N/X** button to return to the Settings menu.

Configure Scope/Meter

These menu options allow you to configure certain characteristics of the display screen to your preference when using the Scope Multimeter module.

- See [Trigger Auto/Manual Mode \(Optional Setting\)](#), on page 100 for Trigger Mode settings.
- For Display and Divisions settings, see [Display Settings](#), on page 109.

Configure Units

Selecting opens a dialog box that allows you to choose between US customary or metric units of measure for temperature, vehicle speed, air pressure, and other pressures.



Figure 11-10 *Configure units menu*



To change the units setup:

1. Select **Tools** from the Home screen to open the menu.
2. Select **Configure Units** to open the menu.
3. Select an item from the Configure Units menu.
4. Select a setting from the listed choices.
5. Select **Back** on the toolbar or press the **N/X** button to return to the options menu.

This chapter describes basic cleaning and battery replacement procedures for your Diagnostic Tool.

12.1 Cleaning and Inspecting the Diagnostic Tool

Periodically perform the following tasks to keep your Diagnostic Tool in proper working order:

- Check the housing, cables and connectors for dirt and damage before and after each use.
- At the end of each work day, wipe the Diagnostic Tool housing, cables and connectors clean with a damp cloth.

IMPORTANT:

Do not use any abrasive cleansers or automotive chemicals on the Diagnostic Tool.

12.1.1 Cleaning the Touch Screen

The touch screen can be cleaned with a soft cloth and a mild window cleaner.

IMPORTANT:

Do not use any abrasive cleansers or automotive chemicals on the touch screen.

12.2 Battery Pack Service

Follow all safety guidelines when handling the battery pack.

 **WARNING**

Risk of electric shock.

- **Prior to recycling the battery pack, protect exposed terminals with heavy insulating tape to prevent shorting.**
- **Disconnect all test leads and turn Diagnostic Tools off before removing the battery pack.**
- **Do not attempt to disassemble the battery pack or remove any component projecting from or protecting the battery terminals.**
- **Do not expose the Diagnostic Tool or battery pack to rain, snow, or wet conditions.**
- **Do not short circuit the battery terminals.**

Electric shock can cause injury.

 **WARNING**

Risk of explosion.

- **Use the proper factory battery pack only, incorrect replacement or tampering with the battery pack may cause an explosion.**

Explosion can cause death or serious injury.

12.2.1 Battery Pack Safety Guidelines

IMPORTANT:

The battery pack contains no user serviceable components. Tampering with the battery pack terminals or housing will void the product warranty.

Keep the following in mind when using and handling the battery pack:

- Do not short circuit battery terminals.
- Do not immerse the Diagnostic Tool or battery pack in water, or allow water to enter the Diagnostic Tool or battery compartment.
- Do not crush, disassemble, or tamper with the battery pack.
- Do not heat the battery pack to over 100°C (212°F), or dispose of it in a fire.
- Do not expose the battery pack to excessive physical shock or vibration.
- Keep the battery pack out of reach of children.
- Do not use a battery pack that appears to have suffered abuse or damage.
- Store the battery pack in a cool, dry, well ventilated area.



NOTE:

The battery pack should be used within a short period of time (about 30 days) after charging to prevent loss of capacity due to self-discharging.

If long-term storage of the battery pack is necessary, it should be stored in a cool, dry, well ventilated place with a 30 to 75 percent state of charge to prevent loss of characteristics.

To prolong the life of your battery, power off the Diagnostic Tool when not in use. The Diagnostic Tool has a built in charger that recharges the battery on demand whenever it is connected to a power source.

12.2.2 Replacing the Battery Pack

If the battery pack no longer holds a charge, contact your sales representative to order a new battery.

IMPORTANT:

Replace the battery pack with original Snap-on replacement parts only.

**To remove the battery pack:**

1. Loosen the two battery cover screws on the back-side of the diagnostic tool.
2. Pull up and out on the lower edge of the battery cover to release it.
3. Remove the battery pack in the same manner as the battery cover, pulling the bottom edge up and tilting out.

**To install the battery pack:**

1. Position the battery pack as shown in (Figure 12-1) with the arrows facing up.
2. Tilt the top of the battery in to align the tabs, then down to install into place.
3. Install the battery pack cover, in the opposite manner as removal, aligning the tabs and tilting down and in, into place.
4. Tighten the battery cover screws. **Do not overtighten the screws!**

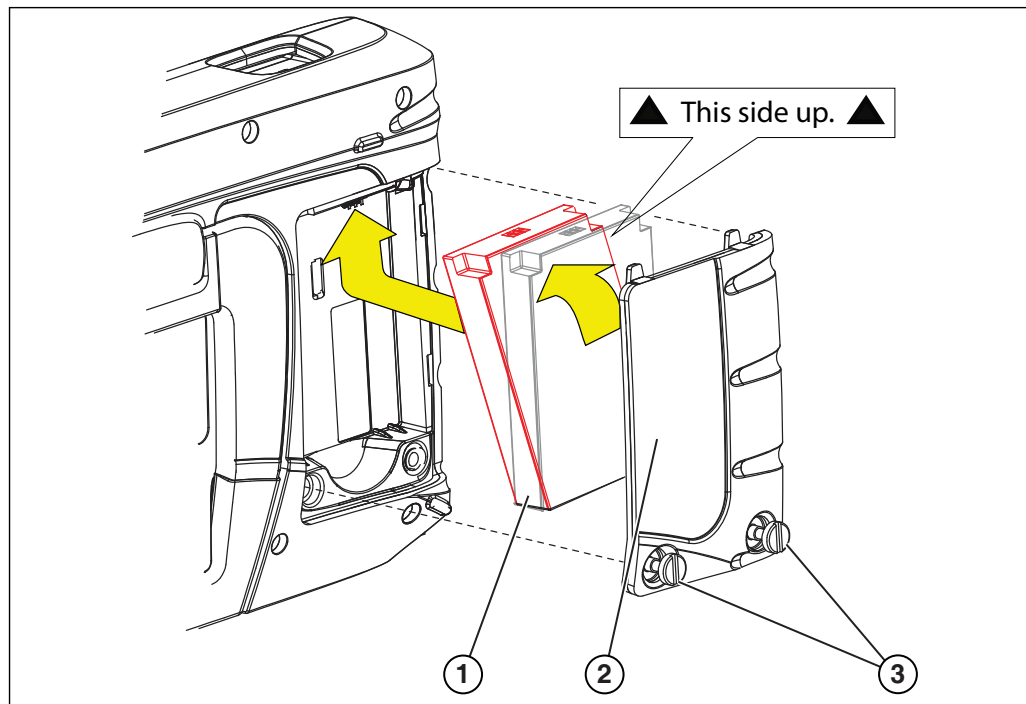

- 1— Battery Pack
2— Battery Cover
3— Battery Cover Screws

Figure 12-1 Battery pack installation

12.2.3 Disposing of the Battery Pack

Always dispose of the battery pack according to local regulations, which vary for different countries and regions. The battery pack, while non-hazardous waste, does contain recyclable materials. If shipping is required, ship the battery pack to a recycling facility in accordance with local, national, and international regulations. For additional information contact:

- United Kingdom—Electrical Waste Recycling Company at <http://www.electricalwaste.com>

Products bearing the WEEE logo (Figure 12-2) are subject to European Union regulations.



Figure 12-2 WEEE logo



NOTE:

Always dispose of materials according to local regulations.

Contact your sales representative for details.

ALTUS (ALTUSDRIVE.com) - Cloud Sharing/Storage

ALTUS is a mobile-friendly cloud-based application designed specifically for technicians to store, organize and share diagnostic information.

This built-in feature automatically transfers code scan reports from the diagnostic tool to ALTUS (ALTUSDRIVE.com).

Main Topic Links

- [Quick Reference \(print / download / share\)](#)
- [Registration - Getting Started](#)
- [Using ALTUS](#)
 - [ALTUS - New User Registration](#)
 - [ALTUS Setup Information Screen](#)
 - [Logging in to ALTUS \(registered user\)](#)
 - [Navigating ALTUS \(Toolbars\)](#)
 - [My Files](#)
 - [Search](#)
 - [Favorites](#)
 - [Profile](#)
 - [File Detail \(Tags\)](#)
 - [Sharing/E-mail an Individual Report \(Link icon\)](#)
 - [Logging Out of ALTUS](#)

13.1 Key Features

- Automatically transfer code scan reports to ALTUS.
- Access and manage your ALTUS account, using your mobile device or PC.
- Share/send report files via e-mail, or other mobile apps.
- Tag reports (attach a descriptive key-name) to help you organize and search report files.
- Use the Search function to quickly find files by Tag, Description and Title.

13.2 Important Notes

- To use ALTUS, registration and diagnostic tool Wi-Fi connection is required.
- The diagnostic tool only transfers code scan reports to ALTUS.
- ALTUS is continuously monitored for inappropriate content. Abuse (as determined by moderator) will result in account deactivation.

13.3 Registration - Getting Started

To use ALTUS:

- The diagnostic tool must be connected to a Wi-Fi network
- If you are a new user, you will need to create a new account, see [ALTUS - New User Registration](#).

13.3.1 ALTUS - New User Registration

If you are a new user, follow these steps to register and create a new account:



NOTE:

Account setup is only required one time.

1. Connect the diagnostic tool to a Wi-Fi network, see [Turning Wi-Fi On and Connecting to a Network](#), on page 157,.
2. Write down the Serial Number, PIN and Code that are displayed when the device connects to the Wi-Fi network ([Figure 13-1](#)), or leave the screen displayed. Registration information can also be found in the Tools menu, see [ALTUS Setup Information Screen](#), on page 142,.

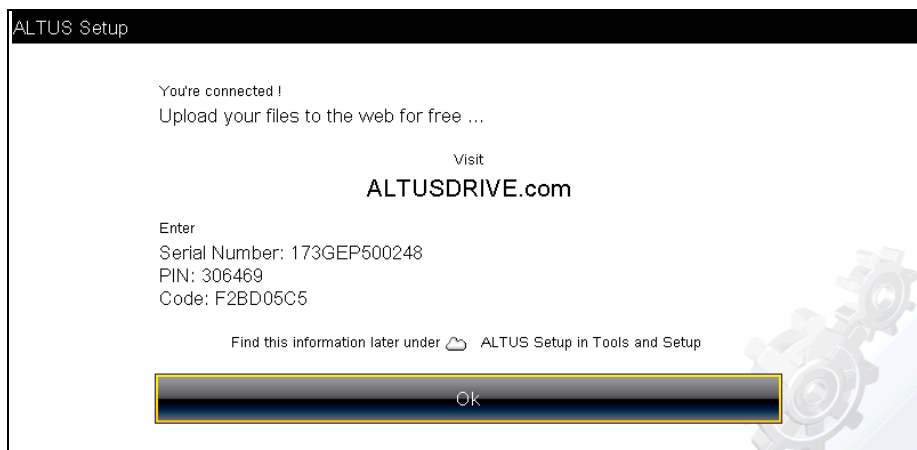

Figure 13-1



NOTE:

The PIN and Code numbers will change each time you view the ALTUS Setup screens ([Figure 13-1](#) and [Figure 13-2](#)). This is normal, any displayed set of PIN and Code numbers may be used to register on ALTUSDRIVE.com.

3. Using a mobile device or PC, visit <https://ALTUSDRIVE.com> and select **Create Individual Account** from the Login screen.
4. Enter the required information and create a **Username** and **Password**, then select **Create**.
5. At the "Success" confirmation screen, select **Done**.
6. Log in using your **Username** and **Password**.
7. Answer the security questions, then select **Submit**.
8. From Technician Profile Manager select the **Device Management** tab.
9. Select **Add Device**, then enter your **Serial Number**, **PIN**, **Code**, and **Device Name** and select **Save** when done.

10. Log out of Profile Manager, then select the **ALTUS Home Page** browser tab to get started.
11. Turn the diagnostic tool off, and then on.
12. See [Using ALTUS](#), on page 143,.

Your Diagnostic diagnostic tool is now registered to your ALTUS online account. Code scan reports will be automatically sent (only when connected to Wi-Fi) to your online account from the device.



NOTE:

If the device is not connected to a Wi-Fi network when the code scan is performed, the report will not be sent to your ALTUS account. Wi-Fi connection is required to upload the report to ALTUS.

13.3.2 ALTUS Setup Information Screen

From the Home screen, selecting **Tools > ALTUS Setup** ([Figure 13-2](#)) allows you view the diagnostic tool serial number, PIN and Code needed to register on ALTUSDRIVE.com.



NOTE:

The PIN and Code numbers will change each time you view the ALTUS Setup screens ([Figure 13-2](#) and [Figure 13-1](#)). This is normal, any displayed set of PIN and Code numbers may be used to register on ALTUSDRIVE.com.

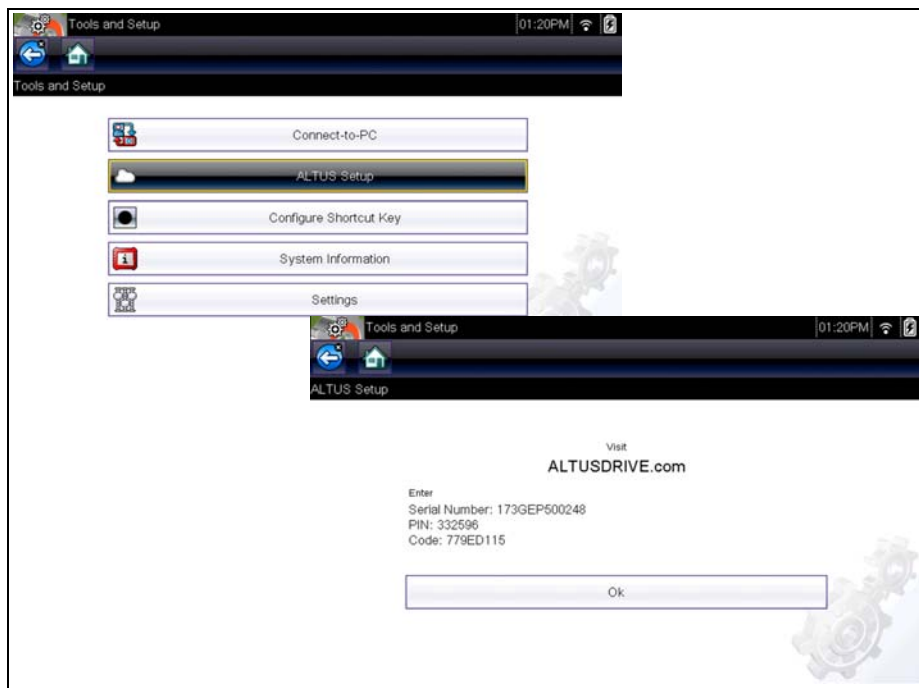

Figure 13-2

13.4 Using ALTUS

To use ALTUS:

- An ALTUS account is required, see [Registration - Getting Started](#), on page 141,.
- The diagnostic tool must be connected to a Wi-Fi network, see [Turning Wi-Fi On and Connecting to a Network](#), on page 157,.

13.4.1 Quick Reference (print / download / share)

- **Downloading Files** - Select the menu icon on the file card (upper right), then select **Download** from the menu options. See (callout #4) in [My Files](#), on page 145,.
- **Printing Files** - Select the menu icon on the file card (upper right), then select **Download** from the menu options (see callout #4 in [My Files](#), on page 145,), once downloaded print the file from your device. Alternate Method - open the file in a new browser tab (see [File Detail \(Tags\)](#), on page 146,) and use the browser viewer tools to print the file. **Note:** *All browsers may not support this feature.*
- **Sharing Individual Files** - Select the link icon on the file card (lower center), then select **Copy to Clipboard** from the pop-up window. See [Sharing/E-mail an Individual Report \(Link icon\)](#), on page 148,.
- **Sharing the Entire Gallery of Files** - Select the menu icon from the upper toolbar (upper right), then select **Copy to Clipboard** from the pop-up window. See [Sharing all Reports \(Share My Gallery\)](#), on page 148,.

13.4.2 Logging in to ALTUS (registered user)

To log in to ALTUS:

1. Using your mobile device or PC visit ALTUSDRIVE.com.
2. Select the **Login** icon ([Figure 13-3](#)).

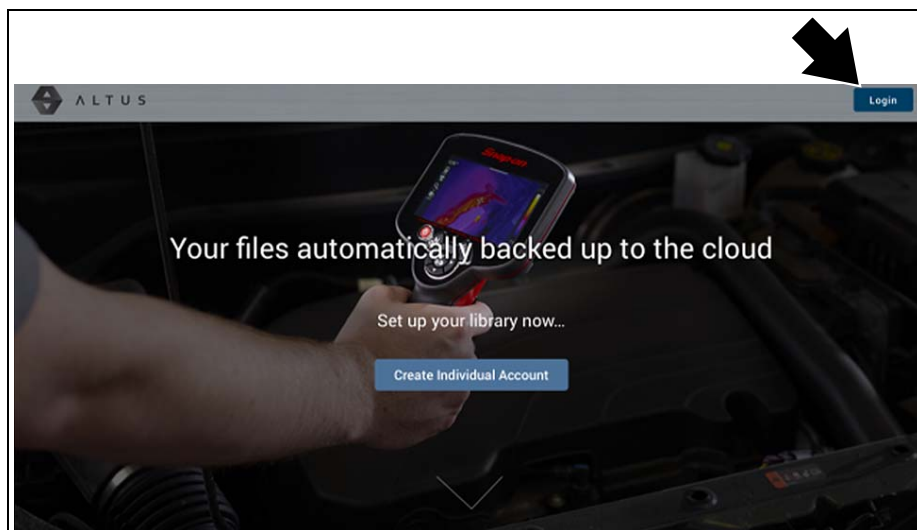

Figure 13-3

3. Log in using your **Username** and **Password** (Figure 13-4).

A login form titled "Login" with a white background and a thin border. It contains two input fields: "Username" and "Password". Below these are two links: "Forgot password? Click here to reset." and "Forgot username? Click here.". A "Remember username & password" checkbox is present. At the bottom, there are three buttons: a blue "Login" button, a grey "Cancel" button, and a link "Create a new Individual Account".

Figure 13-4

13.4.3 Navigating ALTUS (Toolbars)

The upper and lower toolbars are available from all screens.

The upper toolbar includes a menu icon (right side) (Figure 13-5). This menu allows you to share your entire gallery, see [Sharing all Reports \(Share My Gallery\)](#), on page 148,.

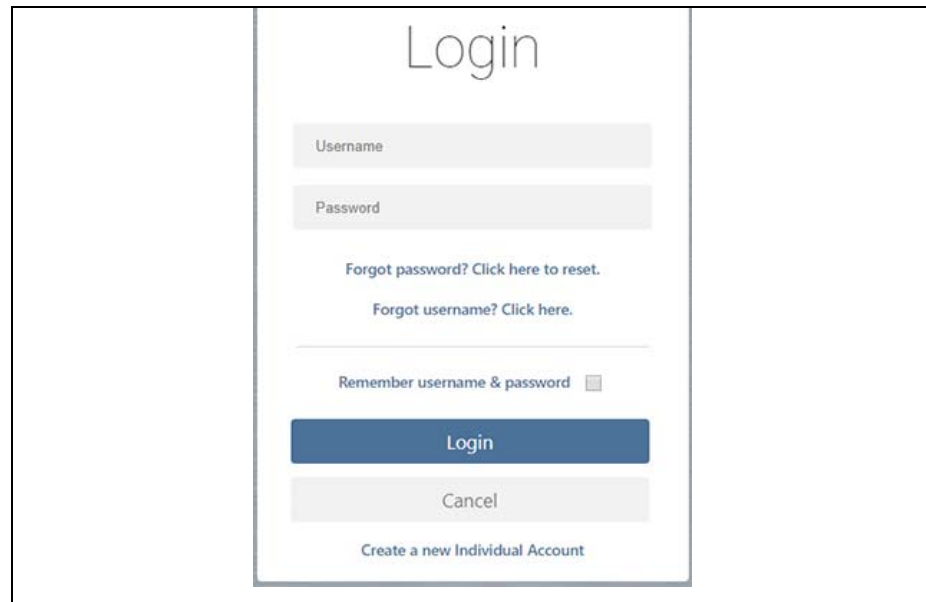

Figure 13-5

The lower toolbar (Figure 13-6) includes the following links:

- [My Files](#), see page 145
- [Search](#), see page 149
- [Favorites](#), see page 150
- [Profile](#), see page 151



Figure 13-6

13.4.4 My Files

My Files displays all the code scan reports uploaded from the diagnostic tool (Figure 13-7). Each report is displayed in a navigation card.

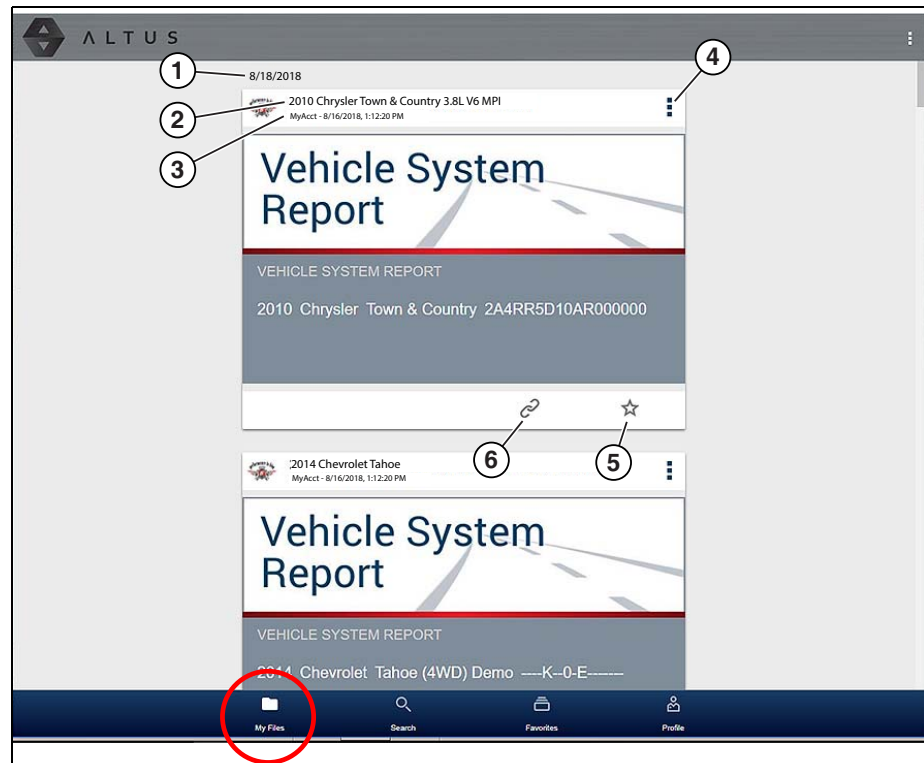

Figure 13-7

- 1— **Report Upload Date** - Reports are displayed with the most recent uploads at the top. The Report upload date is displayed at the upper left. The date is shown once at the top of the series of reports, scroll up / down to see all files within a specific date.
- 2— **Report File Name** - See [File Detail \(Tags\)](#), on page 146, for additional information.
- 3— **Your Account Username (and timestamp)** - See [Account](#), on page 152, for additional information. The timestamp indicates the date/time the file posted on **ALTUSDRIVE.com**
- 4— **Menu Icon - options:**
 - **Download** - Select to download the report to your device.
 - **Delete** - Select to delete the report from ALTUS.
- 5— **Favorites Icon** - See [Favorites](#), on page 150, for additional information.
- 6— **Link icon** - See [Sharing/E-mail an Individual Report \(Link icon\)](#), on page 148, for additional information.

Selecting a report opens the report File Details. The File Detail screen allows you to edit report file metadata.

File Detail (Tags)

As shown in Figure 13-8 selecting (touching) a report from My Files opens the report File Detail card. Selecting the report again opens that report in a new browser tab.

NOTE: Opening the file in a separate browser tab may allow you to use the browser viewer tools to print or download the file. This feature may not be available in all browsers.

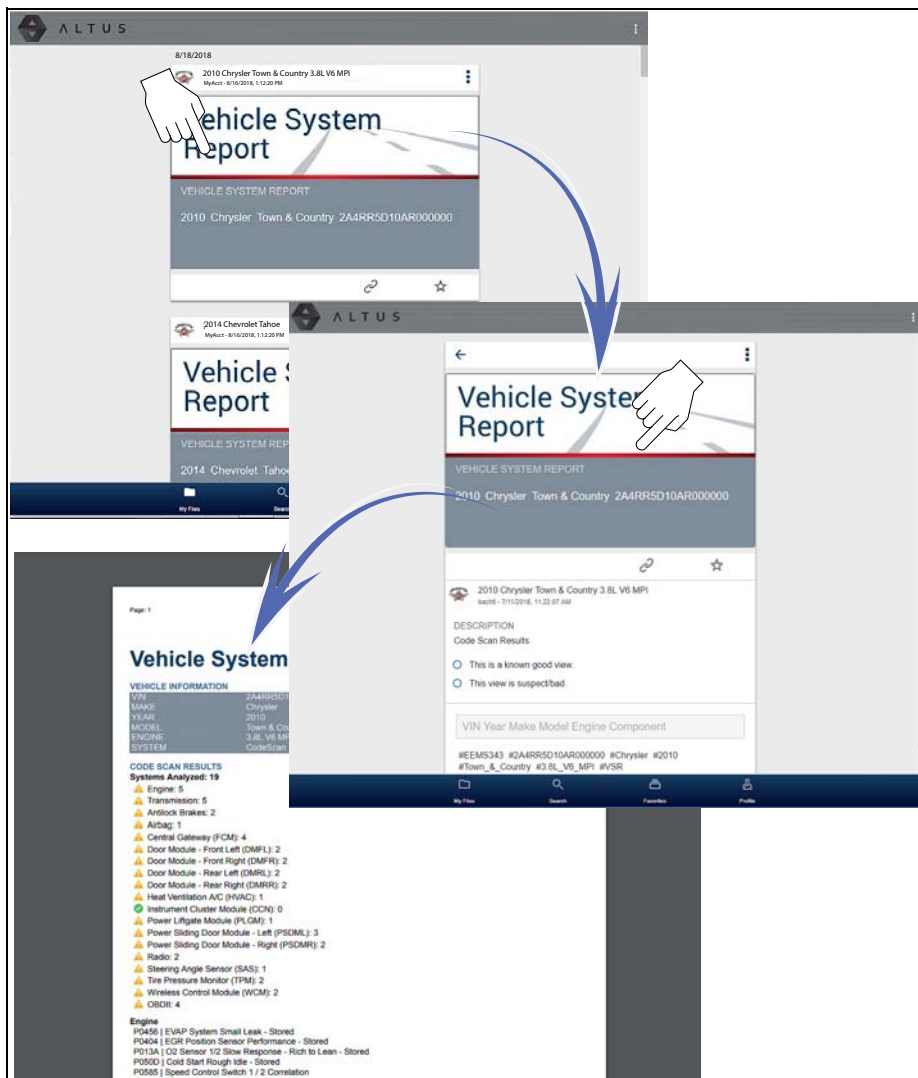

Figure 13-8

The following describes File Detail card features.

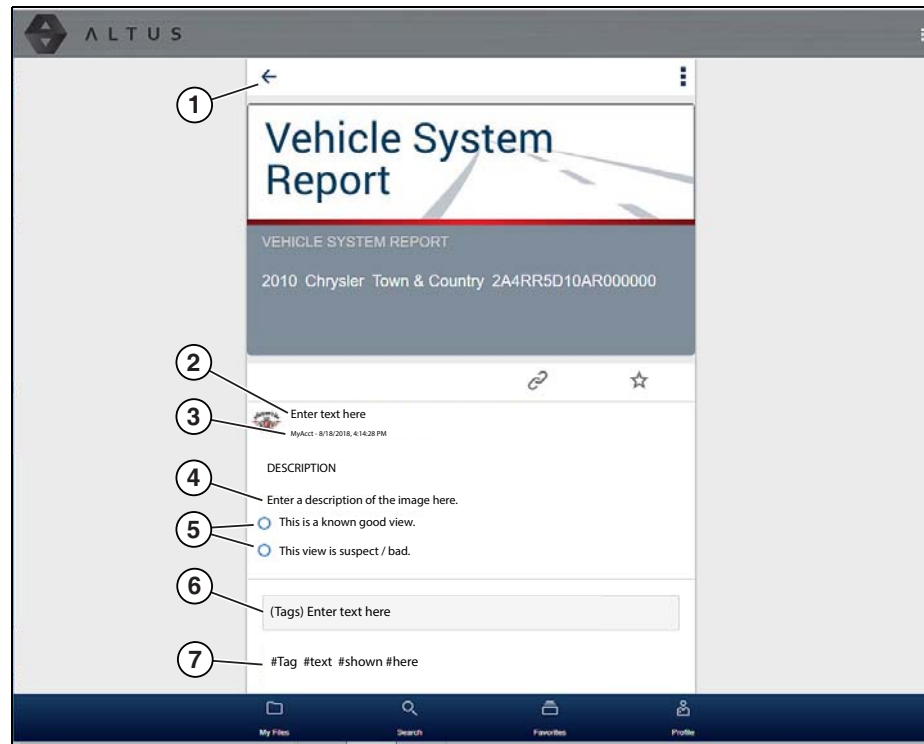

Figure 13-9

- 1— **Back Icon** - Returns to My Files
- 2— **Report Name (user entered searchable text)** - Select the report file name to open the editor. Enter text (alphanumeric) in the field as desired.
- 3— **Your Account Username (and timestamp)** - See [Account](#), on page 152, for additional information. The timestamp indicates the date/time the file posted on [ALTUSDRIVE.com](#)
- 4— **Description (user entered searchable text)** - Enter text (alphanumeric) in the description field as desired.
- 5— **Known Good / Bad Checkboxes (user defined and searchable)** - Selecting a checkbox automatically creates a tag (e.g. #good) and is displayed in the Active Tag(s) field.
- 6— **Tag (user entered searchable text)** - Enter text (alphanumeric) in this field as desired. Tagging a report allows you to associate (tag) descriptive text to a report. Tagging can be used to associate multiple reports with a common tag. The tag text then can be used when performing a search to find all reports with the same tag. Each text entry (word) that is separated by a space (return) is added as a tag, and is displayed in the Active Tag field.
- 7— **Active Tag(s)** - Displays the active tag(s). Tags can include the “good” or “bad” entry from the Known Good / Bad checkboxes, and text entered in the report Name, Description and Tag fields. Each entry is automatically preceded with the “#” symbol.

Sharing/E-mail an Individual Report (Link icon)

To share a report:

1. Select the **Link icon** (Figure 13-10) on the report card.



Figure 13-10

2. Select **Copy to Clipboard** (Figure 13-11) from the pop-up window.



Figure 13-11

3. Open your (e-mail, text, social media, etc.) app and paste the URL into a message to share with others.

The URL link that is sent only displays:

- The Report
- Report Name
- Your User Name
- Date Report was posted
- Report Description

Sharing all Reports (Share My Gallery)

To share your entire gallery (all files in My Files):

1. Select the **Menu** icon (Figure 13-12) from the upper toolbar.



Figure 13-12

2. Select **Share My Gallery**.
3. Select **Copy to Clipboard** (Figure 13-13) from the pop-up window.

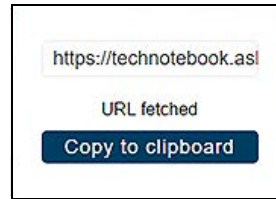

Figure 13-13

4. Open your (e-mail, text, social media, etc) app and paste the URL into a message to share with others.

The URL link that is sent only displays:

- The Reports
- Report Names
- Your User Name
- Date the Reports were posted
- Report Descriptions

13.4.5 Search

The Search screen allows you to perform text searches on all uploaded files and view the results.

To search for a specific file or set of files, enter a **search term** in the search box and select the **magnifying glass** icon (Figure 13-14) (or press Enter).

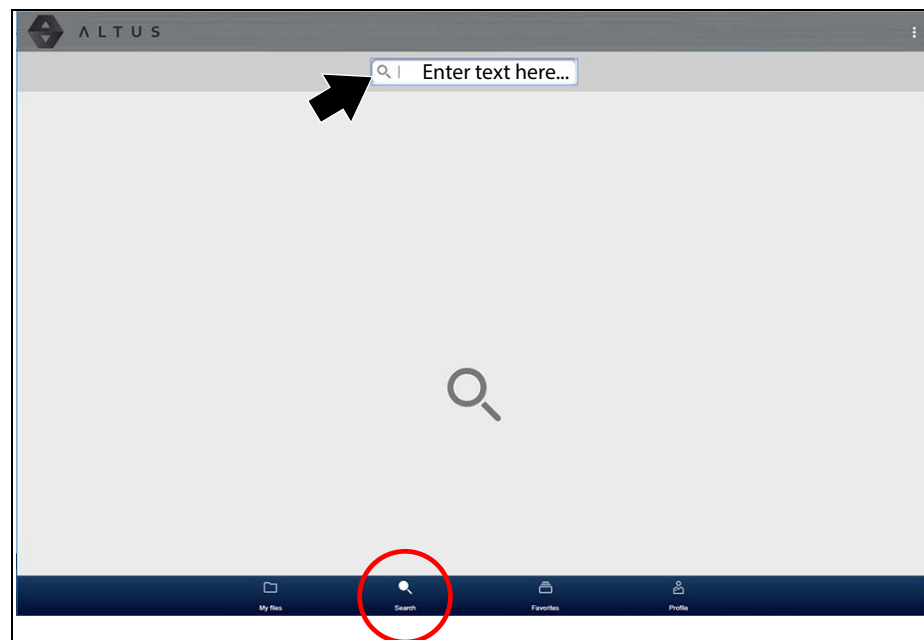

Figure 13-14

Search queries the following to find results:

- **Report File Name** - name can be either system assigned or user assigned

- **Known Good / Bad Checkboxes** - selecting a checkbox automatically creates a searchable tag (e.g. good or bad)
- **Description** - user entered text
- **Tag** - user entered text

See [File Detail \(Tags\)](#), on page 146, for additional information on the above “user entered” text.

13.4.6 Favorites

The Favorites screen displays all the reports selected as favorites ([Figure 13-15](#)).

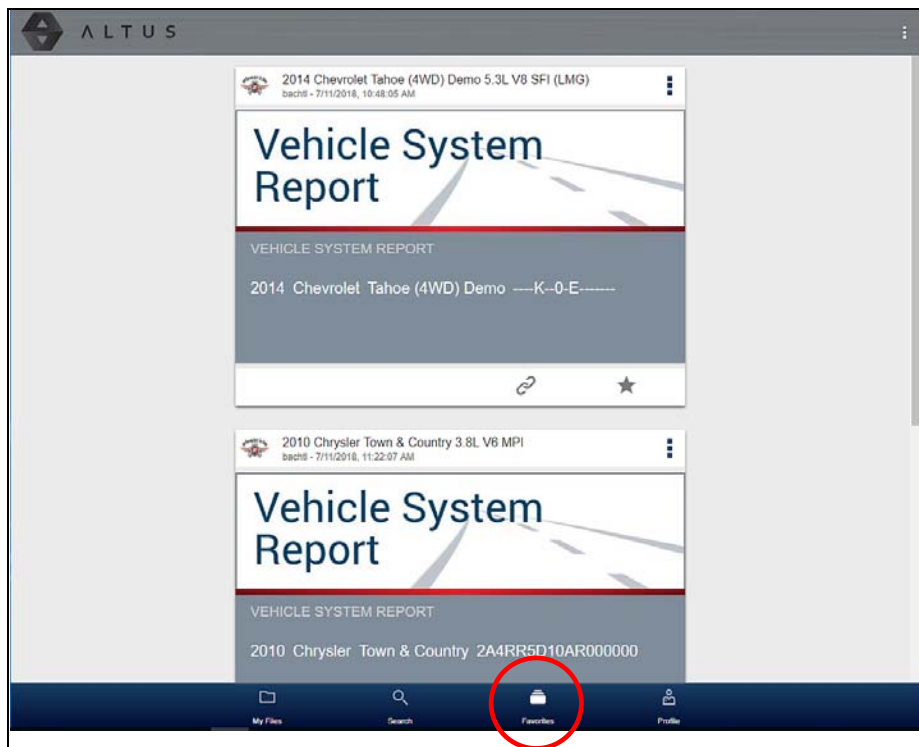



Figure 13-15

To set a file as a “Favorite”, select the **Favorite** icon (star symbol) to highlight the icon.

Description	Icon
Favorite (on)	
Favorite (off)	

The Favorites icon can be selected/deselected at anytime when displaying files.

13.4.7 Profile

The Profile screen allows you to:

- Open Profile Manager ([Figure 13-16](#)), see [Using Profile Manager](#), on page 151,
- Logout of ALTUS, see [Logging Out of ALTUS](#), on page 155,

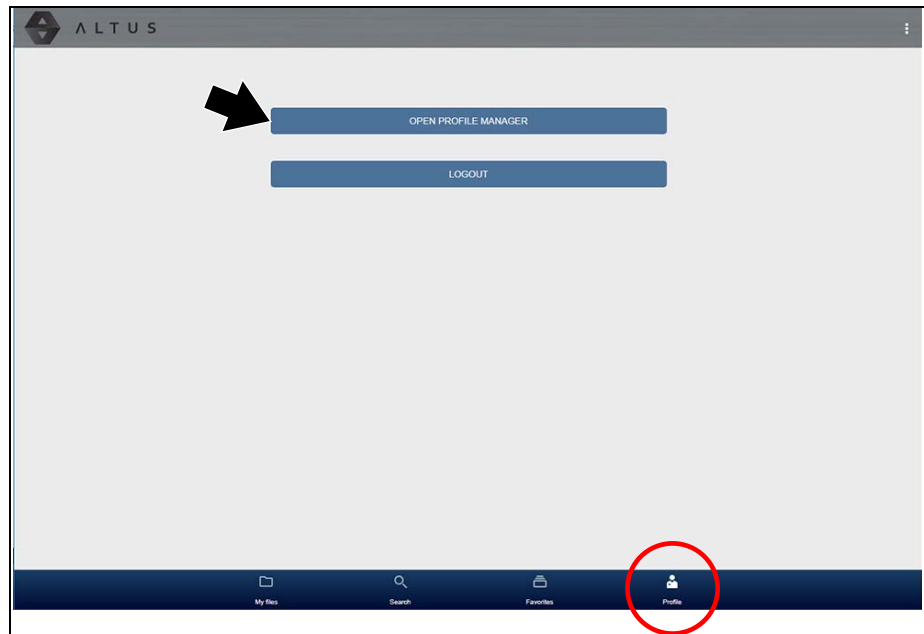

Figure 13-16

Using Profile Manager

1. To open the Profile Manager screen, select **Profile** from lower toolbar, then select **Open Profile Manager** ([Figure 13-16](#)).



NOTE:

Profile Manager opens a new browser tab. To return to ALTUS after logging out of Profile Manager, you must select the ALTUS Home Page browser tab.

2. Enter your **Username** and **Password** at the Login screen.

Profile Manager includes five tabbed categories to help you manage your account information:

- [Account](#), on page 152,
- [Personal Information](#), on page 153,
- [Expertise](#), on page 153,
- [Profile Picture](#), on page 153,
- [Device Management](#), on page 154,

Account

This screen manages the following account information (Figure 13-17):

- Authorization Key (not required for ALTUS account registration)
- Account Expiration Date
- Shop Nickname
- Email
- Username
- Password

Technician Profile Manager Logout

Your Name
New Member

Performance is King

Account Expiration Date

Account Expiration Date

Shop Nickname

Online Profile

Email* Email Confirm*

Username

Cancel Save

Figure 13-17

Personal Information

This screen manages the following personal account information (Figure 13-18):

- First Name
- Last Name
- City
- State
- Zip Code

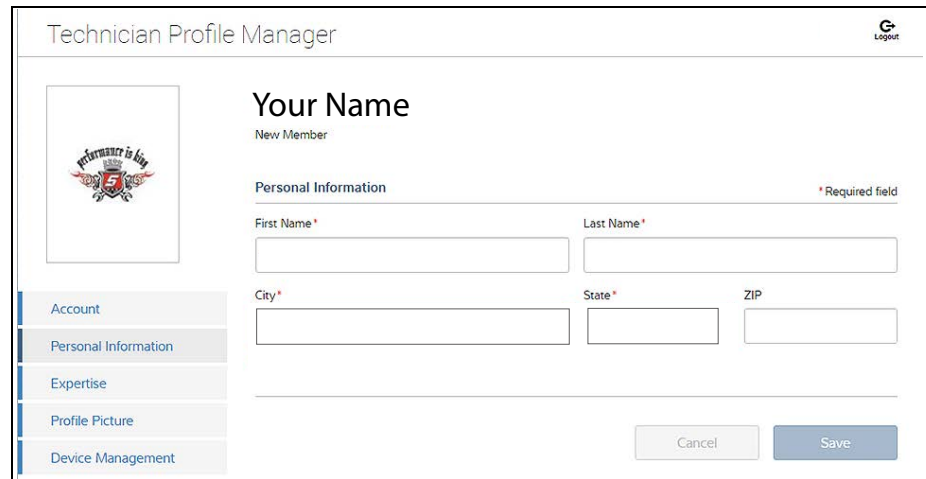

The screenshot shows the 'Technician Profile Manager' interface. At the top left is the title 'Technician Profile Manager' and a 'Logout' link. Below the title is a profile picture placeholder with a logo that says 'Performance is big'. To the right of the profile picture, the text 'Your Name' is displayed, followed by 'New Member'. Below this is the 'Personal Information' section, which is marked as a '* Required field'. The form contains five input fields: 'First Name *', 'Last Name *', 'City *', 'State *', and 'ZIP'. At the bottom right of the form are 'Cancel' and 'Save' buttons. A sidebar on the left contains navigation links: 'Account', 'Personal Information', 'Expertise', 'Profile Picture', and 'Device Management'.

Figure 13-18

Expertise

This tab applies to North American users only.

Profile Picture

This screen allows you to personalize your profile picture, by selecting one of the provided images.

Device Management

This screen manages devices associated with your account (Figure 13-19).

Select **Add a Device** to setup and add an authorized device (e.g. Diagnostic Tool or Diagnostic Thermal Imager).

Enter the device:

- **Serial Number** - serial number of the device
- **Code** - authorization code specific to the device
- **PIN** - specific PIN associated to the device
- **Device Name** - user define name

When finished select **Save** to save and link the device to your account.

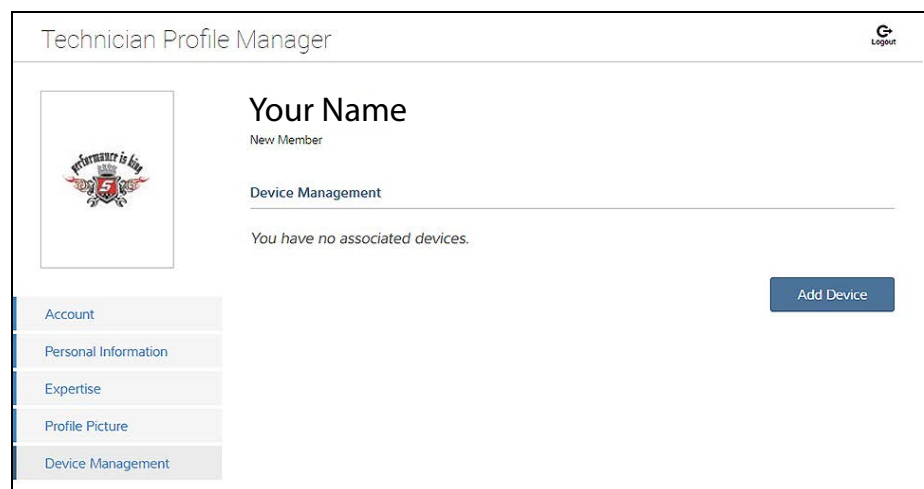

Figure 13-19

Logging Out of Profile Manager

Select the **logout** icon (upper right screen) to log out of Profile Manager (Figure 13-20).



Figure 13-20



NOTE:

Profile Manager opens a new browser tab. To return to ALTUS after logging out of Profile Manager, you must select the ALTUS Home Page browser tab.

Logging Out of ALTUS

To log out of ALTUS select **Profile** from lower toolbar, then select **Logout** (Figure 13-21).

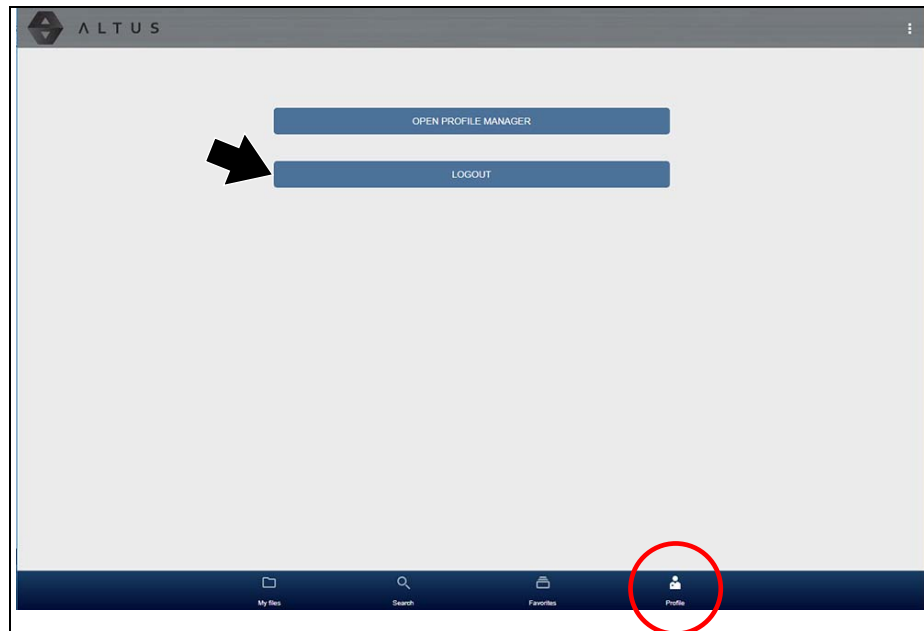

Figure 13-21

Wi-Fi Connection / Troubleshooting

The diagnostic tool is equipped with many features that require Wi-Fi connection.

The Wi-Fi connection is solely dedicated to our Snap-on Web Services Network.

To use features like SureTrack and ALTUS, a Wi-Fi connection is required. Authorization and registration is also required to use some of these features.

This section includes information on Wi-Fi connection and troubleshooting.

Main Topic Links

- [Checking if Wi-Fi is On/Off](#) page 156
- [Checking if Wi-Fi is Connected](#) page 157
- [Wi-Fi Icons \(Setup\)](#) page 157
- [Turning Wi-Fi On and Connecting to a Network](#) page 157
- [Add Network Advanced \(Connecting to a hidden network\)](#) page 159
- [Wi-Fi Testing](#) page 159
- [Wi-Fi Troubleshooting and Status Messages](#) page 161



14.1 Checking if Wi-Fi is On/Off

If the Wi-Fi indicator is displayed in the title bar, Wi-Fi is on. If Wi-Fi is off, see *Turning On Wi-Fi and Connecting to a Network* to turn it on and connect.







14.2 Checking if Wi-Fi is Connected

Check the Wi-Fi indicator in the title bar:

	Wi-Fi is on and connected to a network (1 to 3 bars).
	Wi-Fi is on, but not connected (zero bars). See Wi-Fi Troubleshooting and Status Messages , on page 161.

14.3 Wi-Fi Icons (Setup)

Familiarize yourself with the following Wi-Fi icons and indicators from the Wi-Fi configuration screen.

Wi-Fi Icon (toggle type)		Wi-Fi Test Icon	Wi-Fi Signal Strength Indicator	
				
Select to turn Wi-Fi ON	Select to turn Wi-Fi OFF	Select to open the Wi-Fi Test screen	Zero bars indicates no signal	Three bars indicate full strength signal
Displayed on Wi-Fi configuration screen only			Displayed on the title bar next to the battery level indicator	

14.4 Turning Wi-Fi On and Connecting to a Network

1. From the Home screen, select **Tools > Settings > Configure Wi-Fi**.
2. Select the **Wi-Fi** icon (with checkmark) ([Figure 14-1](#)) to turn Wi-Fi on.



Figure 14-1 Wi-Fi Icon (shown off)

3. The Wi-Fi icon will change to the Wi-Fi symbol with “x” mark ([Figure 14-2](#)), indicating Wi-Fi is on.

The screen will change to display available supported network connections.

4. Select your network. Use the scroll feature to show all active connections (Figure 14-2).

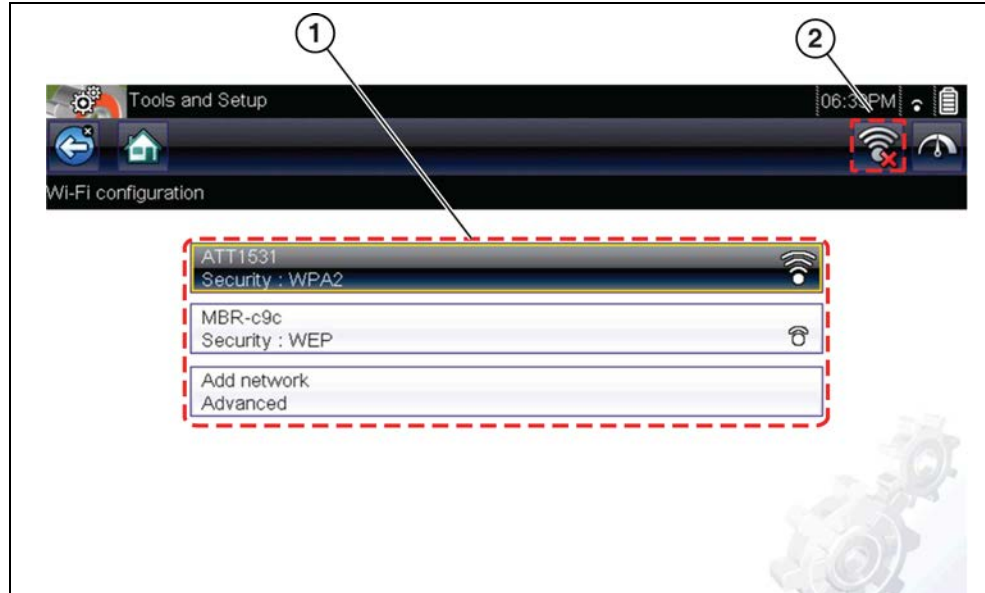

Figure 14-2 Wi-Fi Configuration Screen

1— Available Network Connections

2— Wi-Fi Icon (Wi-Fi shown on)



NOTE:

A password is required when choosing a secured (protected) network. Enter the password using the on-screen keyboard and then select the check mark on the keyboard to continue.

Networks with a proxy, challenge page, or that require the user to accept terms of usage are not supported.

Wi-Fi performance varies depending on your wireless network equipment and ISP.

5. Select **Connect** to connect to your desired network or **Cancel** to cancel the request.
6. From the Connect confirmation screen select **OK** to continue using this connection or **Forget** to disconnect this connection.
 - The screen will change to display your confirmed network connection and ALTUS registration information. For ALTUS registration information see [ALTUS \(ALTUSDRIVE.com\) - Cloud Sharing/Storage](http://ALTUS (ALTUSDRIVE.com) - Cloud Sharing/Storage), on page 140.
 - If the status message “Not Connected” is displayed, retry the configuration process or see [Wi-Fi Testing on page 159](#) for additional information.

14.5 Add Network Advanced (Connecting to a hidden network)

The Add Network selection allows you to connect to a network that is not broadcasting its name (not visible in the displayed network list). These networks are also known as "hidden" networks.

To connect to a hidden network you will first need to know the following:

- Network Security Type
 - Open (only need SSID)
 - WPA or WPA2 (Pre-shared key)
 - WEP (WEP key)
- Network name or SSID (Service Set Identifier)
- Network Password



Connecting to a Hidden Wi-Fi Network

1. From the Home screen, navigate to **Tools > Settings > Configure Wi-Fi**.
2. Select **Add Network Advanced** from the network list (scroll to end of list).
3. Select security type Open, WPA, WPA2, or WEP. Refer to the router user manual or your IT administrator to determine the type.
4. Enter the network name or SSID
5. Enter the network password.
6. Select **Connect** at the prompt to connect to the network.
7. Select **OK** at the confirmation screen to continue using this connection, or Forget to disconnect this connection.

14.6 Wi-Fi Testing

If you are experiencing network connection issues, an automated testing feature is available to quickly test your network connection.



Testing Connections

1. Before you start the automated testing procedure, turn off the diagnostic tool and then turn it on. This clears previous testing messages from memory.
2. Connect to your desired network, see [Turning Wi-Fi On and Connecting to a Network on page 157](#).
3. From the Wi-Fi configuration screen, select the **Wi-Fi Test** icon to open the network connection test screen ([Figure 14-3](#)).



Figure 14-3 [Wi-Fi Test Icon](#)

The network connection test is an automated test that begins when the screen is displayed. Network connection systems are tested in sequence and display a status indicator (Red = test failed, Yellow = test is process, or Green = test completed satisfactorily) when finished (Figure 14-4).

Connectivity of the following systems are checked:

- **Hardware**
- **Router**
- **Internet**
- **HTTP**
- **Web Services Network**

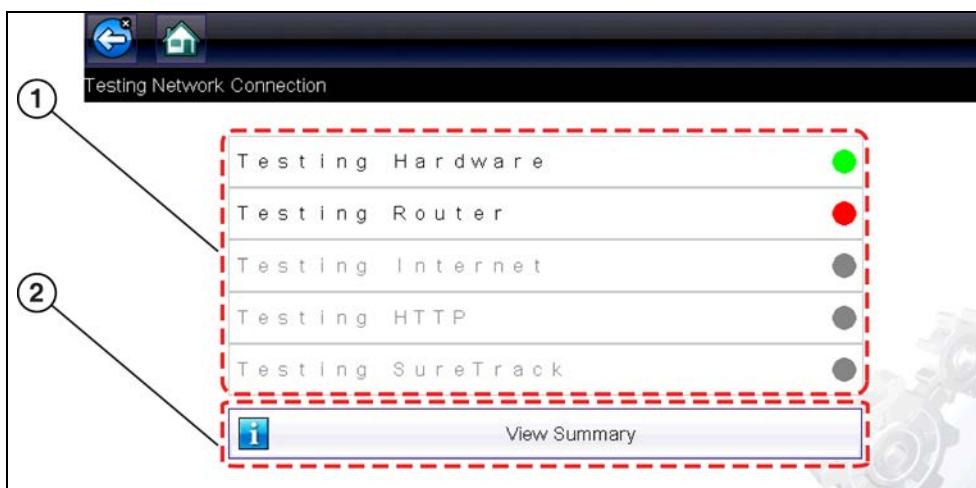

Figure 14-4 Connection Tests

- 1— Connection Tests
- 2— View Summary

4. If a connection issue(s) is present, select **View Summary** to review the results. The summary information is helpful if you are experiencing difficulties with your connection (Figure 14-5). Scroll through the summary information to review the test results for each system and Tip messages for the current connection issue. See *Connection Tests - Troubleshooting* chart in [Wi-Fi Troubleshooting and Status Messages on page 161](#) for additional information.

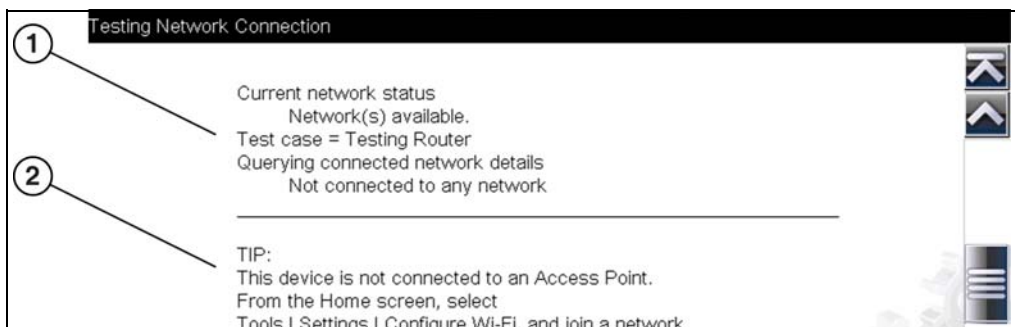

Figure 14-5 View Summary

- 1— Connection Test Results
- 2— Connection Issue Tip Message

14.7 Wi-Fi Troubleshooting and Status Messages

The following troubleshooting information is not inclusive and is meant as a guide only. Other issues and solutions may arise that are not stated here. The following description of terms are provided for reference as used in the following troubleshooting chart:

- **Router** - The data transmission device directly connected to your ISP.
- **Remote Wireless Access Point** - A wireless connection device between the router and your diagnostic tool.
- **Wi-Fi Radio** - The internal diagnostic tool radio transmitting and receiving Wi-Fi signals.
- **Network Connection** - Also called Wi-Fi connection. The configured Wi-Fi router connection the diagnostic tool connects to. This connection can be secured (password protected) or unsecured (open).

Router Information

Router compatibility and setup are important factors to check when trying to determine connectivity problems. Although we have tested this device at the factory to verify connectivity, we cannot guaranty its connectivity with your specific equipment. There may be some situations that require your time for router connection troubleshooting and/or additional consultation and equipment. Snap-on Incorporated is not responsible for any costs incurred for any additional equipment, labor or consultation charges or any other costs that may result from correcting non-connectivity issues with this device.

Check Router Settings

Verify the following router settings **BEFORE** you begin troubleshooting a non-connectivity or "No Connection" problem. After each check, make any corrections as necessary then retest for connectivity. **Contact your IT administrator or ISP for assistance.**

1. Check your router connection and if applicable, the remote wireless access point connection.
2. Clear saved Wi-Fi networks, see [Clearing Wi-Fi Networks](#), on page 161.
3. Verify:
 - (a). Router is configured to use Dynamic Host Configuration Protocol (DHCP), not a static IP address.
 - (b). Router and/or settings for this device are configured to 2.4GHz. 5GHz is not supported.
 - (c). Router is configured to B/G and/or N standard wireless networks to 2.4GHz. 5GHz is not supported. See your router "User Guide" for setup, connection and troubleshooting procedures.
4. Check for router firmware and update to current version, if applicable.
5. Restart or reset the router. See your router "User Guide" for procedures.
6. Connect to a different router.

Clearing Wi-Fi Networks

1. Select the Wi-Fi network that you are trying to connect to from the list of saved networks on the Wi-Fi configuration menu.
The Wi-Fi Summary page displays.
2. Select **FORGET**
The Wi-Fi Configuration menu displays.

3. Repeat steps (1) and (2) for ALL saved Wi-Fi networks.
4. Once all saved Wi-Fi networks have been deleted (forgotten) turn off the diagnostic tool.
5. Turn on the diagnostic tool and connect to the desired Wi-Fi network, see [Turning Wi-Fi On and Connecting to a Network](#), on page 157.

General -Troubleshooting		
Problem	Possible Cause	Corrective Action
Repair Information Applications (e.g. Intelligent Diagnostics, Oil Specs and Resets) are not available	Access has expired	Contact your sales representative.
	Access may be temporarily unavailable	Try to access the function at a later time as updates may be in process.
	Wi-Fi radio is turned Off	1. From the Home screen, navigate to Tools > Settings > Configure Wi-Fi . 2. Select the Wi-Fi icon and turn the Wi-Fi radio on. The Wi-Fi icon will change from a green check mark icon to red "X" mark icon indicating Wi-Fi radio is on. 3. Connect to a known good network.
	Not connecting to a network	1. Clear saved Wi-Fi networks, see Clearing Wi-Fi Networks , on page 161. 2. Connect to a network. 3. From the Configure Wi-Fi screen select the Wi-Fi Test icon and review the results. See Connection Tests - Troubleshooting in the following table.
Wi-Fi connection drops off or disconnects intermittently	Wi-Fi Signal strength insufficient	Check Wi-Fi signal strength - out of range or interference. Move closer (within 50 Ft. (15 M) or into a direct open sight-line of the router or if applicable, remote wireless access point. Eliminate interference from overhead lights, windows, walls, other wireless devices, metal objects and devices that emit electrostatic discharge.
	Router overloaded	Disconnect/disable other Wi-Fi devices connected to the router.

Connection Tests - Troubleshooting		
Failed Test	Possible Cause (Displayed Tip Message*)	Corrective Action / Checks
Hardware	Wi-Fi radio not responding and/or will not turn off	Contact Customer Support for assistance.
	Wi-Fi radio not responding and/or will not initialize	
	Missing or corrupt firmware file(s)	

Router	This device is not connected to a router	Check Wi-Fi signal strength - out of range or interference. Move closer (within 50 Ft. (15 M) or into a direct open sight-line of the router or if applicable, remote wireless access point. Eliminate interference from overhead lights, windows, walls, other wireless devices, metal objects and devices that emit electrostatic discharge.
		Check router connection and setup. See Check Router Settings , on page 161 for procedure.
Internet	This device is not connected to the Internet or has no DNS	Check router connection and setup. See Check Router Settings , on page 161 for procedure.
		Domain Name System (DNS) server not connected. Contact your Internet service provider (ISP).
HTTP	This device cannot communicate using HTTP	Check if your Internet access uses a "Proxy" or "Accepting terms in a browser" protocol, or uses a challenge page. These protocols are not supported by this device. Contact your IT administrator or ISP for options.
Web Services Network (e.g.access to Intelligent Diagnostics, Oil Specs and Resets)	Your access has expired	Contact your sales representative.
	Repair Information Services may be temporarily unavailable or Not connecting to a network	Try to access at a later time as Repair Information Services may be performing updates to the service.
		Check router connection and setup. See Check Router Settings , on page 161 for procedure.
* See Wi-Fi Testing , on page 159 for additional information.		

14.7.1 Informative Messages

Messages may be displayed to inform you of pending issues or general status. Depending on your access and connection status, the following are typical messages that may be displayed:

- **Content May Be Available!** - indicates content may be available, however you are not currently connected to the Web Services Network. This message may be caused by a Wi-Fi connection issue, or you do not have access to the feature. See [Wi-Fi Troubleshooting and Status Messages](#), on page 161 for Troubleshooting information.
- **No connection. Please try again later.** - indicates you are not currently connected to the Web Services Network, except when displayed in the OBD/EOBD function as Repair Information Applications are not accessible in OBD/EOBD mode. If this message is displayed in the Scanner function, it may be caused by a Wi-Fi connection issue, or you do not have access to the feature. See [Wi-Fi Troubleshooting and Status Messages](#), on page 161 for Troubleshooting information.
- **Loading content** - indicates information is being accessed from the Web Services Network.
- **A new diagnostic software upgrade is available. Contact your sales representative for details.**
- **Your access has expired. See your Sales representative to renew.** - indicates your access to the Web Services Network has expired and you should contact your sales representative.

This chapter includes a brief introduction to some of the key features of the ShopStream Connect software. For detailed ShopStream Connect information and instructions, download the ShopStream Connect User Manual from our website:

<https://www.snapon.com/diagnostics/uk/User-Manuals.htm>

The ShopStream Connect™ (SSC) software is PC-based software that extends the capabilities of your diagnostic tool. Using ShopStream Connect software with your diagnostic tool allows you to do the following:

- View, Print, and Manage data saved from your Diagnostic tool.
- Move and copy your data between the diagnostic tool and your PC.
- View and Print trouble codes saved with select diagnostic tools. This allows you to share the data in a report format with vehicle owners or other technicians.
- Add or edit notes and comments to diagnostic tool data files.
- Download and install diagnostic tool software updates and upgrades.

The ShopStream Connect (SSC) software is available (free of charge) at:

ShopStream Connect -

<https://www.snapon.com/diagnostics/UK/Diagnostics/ShopStreamConnect.htm>

15.1 Using SSC (Connecting to your PC)



To connect and use SSC with your diagnostic tool:

1. Download and install SSC on your PC from:
<https://www.snapon.com/diagnostics/UK/Diagnostics/ShopStreamConnect.htm>
2. Turn your diagnostic tool on.
3. Connect the supplied USB cable from the USB jack on your diagnostic tool to your PC:
4. From the diagnostic tool Home screen, select **Tools > Connect-to-PC**.

The “**Device is now in Connect-to-PC mode**” screen message is displayed (Figure 15-1) and the ShopStream Connect software will open automatically on your PC (Figure 15-2).

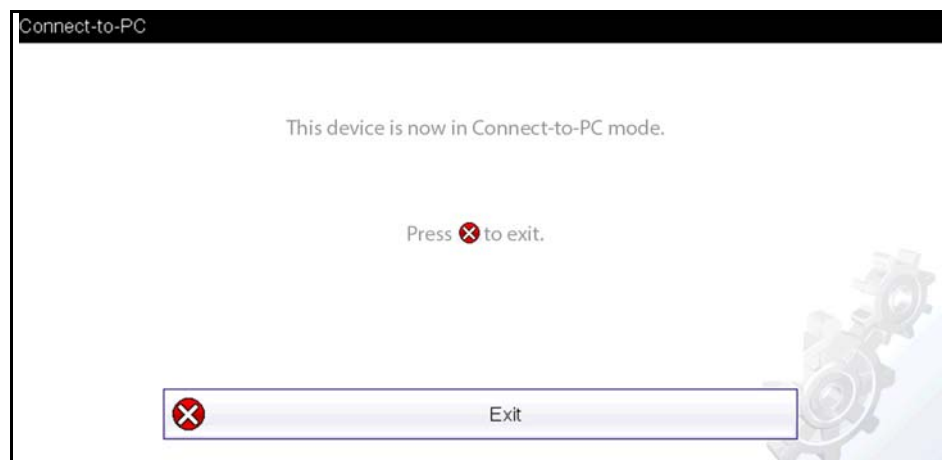

Figure 15-1

If the ShopStream Connect software does not open, open it from the Windows Start menu or use the ShopStream Connect shortcut icon on the Windows desktop (automatically created during installation).

15.2 SSC Main Screen

The ShopStream Connect software will open automatically when you connect the diagnostic tool to your PC USB connection, [Using SSC \(Connecting to your PC\)](#), on page 164,.

The following shows the main screen layout for ShopStream Connect software.

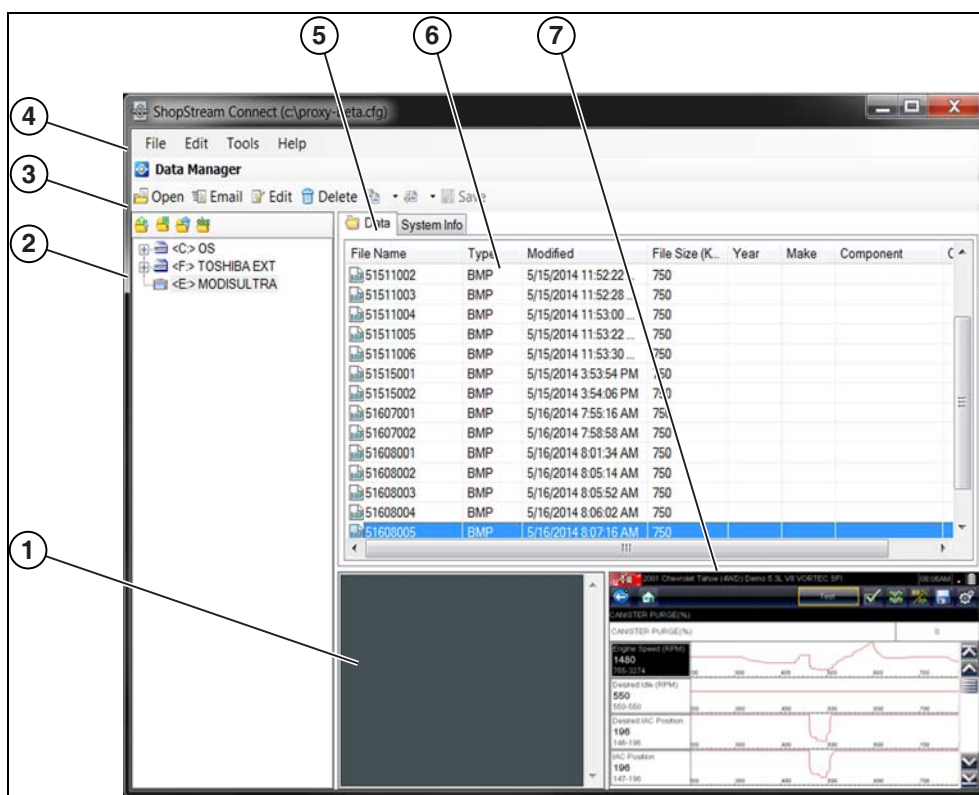

Figure 15-2

- 1— **Notes Window**—allows you add notes to select data files. Select Save from the menu bar to save your notes. *NOTE: Not all file types allow notes, the Notes window will be grayed out when a file type that does not support notes is highlighted. Some image files may display notes for reference purposes (the notes are grayed out and not editable).*
- 2— **File directory structure**—displays the file directory structure of your PC in standard Windows format, and shows any connected diagnostic tools at the bottom of the data list.
- 3— **Data Manager Toolbar**—provides control icons that perform a variety of operations on data files.
- 4— **Main Menu bar**—contains **File**, **Edit**, **Tools**, and **Help** menus.
- 5— **Tabs**—provides access to data files and presets stored on the diagnostic tool or on the PC, and also allows viewing of software revision details of the diagnostic tool.

- 6— **Main display**—shows stored data files details. *NOTE: The files listed are sortable (ascending/descending) by clicking on the column tab at the top (e.g. File Name, Type, etc.) Sort preferences are saved when the ShopStream Connect program is closed.*
- 7— **Preview**—displays a sample of the file if the selected file is a image file.

15.3 Scanner DataViewer

SSC allows you to view data files recorded with your diagnostic tool, on your PC. When a Scanner data file is selected, it opens and displays in the Scanner DataViewer (Figure 15-3). Scanner DataViewer allows you play the data file and custom configure the data in a number of ways.



- 1— **Menu bar**
- 2— **Display toolbar**
- 3— **Graph display**
- 4— **Properties icon**
- 5— **Vertical Scroll bar**
- 6— **Zoom controls**
- 7— **Slider bar**
- 8— **Navigation toolbar**
- 9— **Parameter text list**
- 10— **Highlighted PIDs** - indicates graphs currently displayed
- 11— **Parameter configuration tabs**

Figure 15-3

15.4 Image Viewer

SSC allows you to view and print .bmp, .jpg and .sps image files (screenshots) saved on your diagnostic tool, with your PC.

**NOTE:**

File extension types vary depending on the diagnostic tool. Not all the file extensions described here may be available on your diagnostic tool.

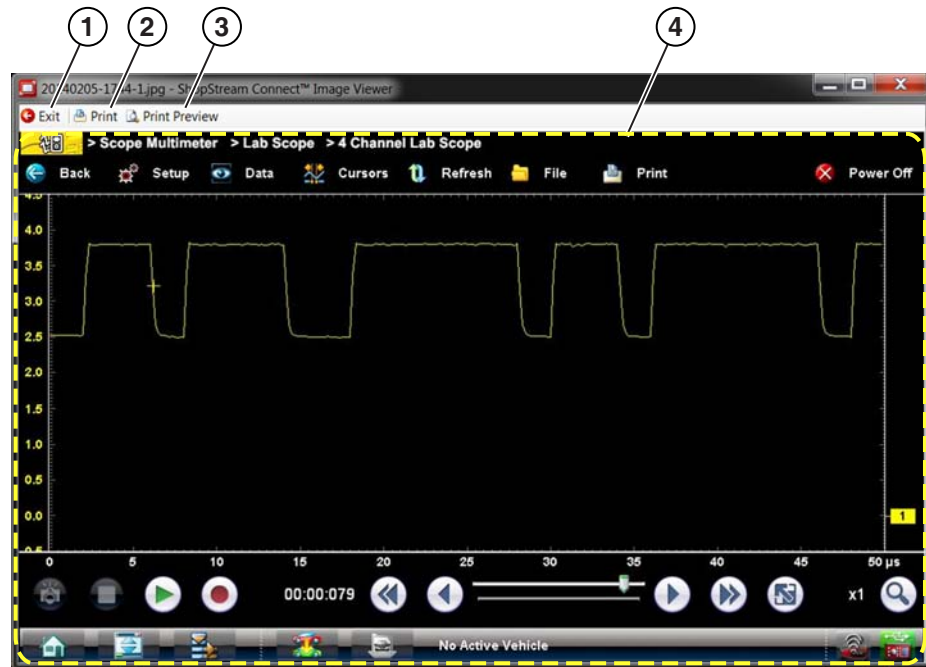

1— Exit - closes the Image Viewer
2— Print - prints the image

3— Print Preview - allows the image to be previewed before printing
4— Captured Screen Image

Figure 15-4

15.5 Printing the (Code Scan) Vehicle System Report

To print the Vehicle System Report, the saved code scan .XML file must be opened using ShopStream Connect.

To print the Vehicle System Report using ShopStream Connect:

1. Double-click the code scan .XML file from the file list to open the Vehicle System Report (Figure 15-5) in the Code Scan Viewer (Figure 15-6).

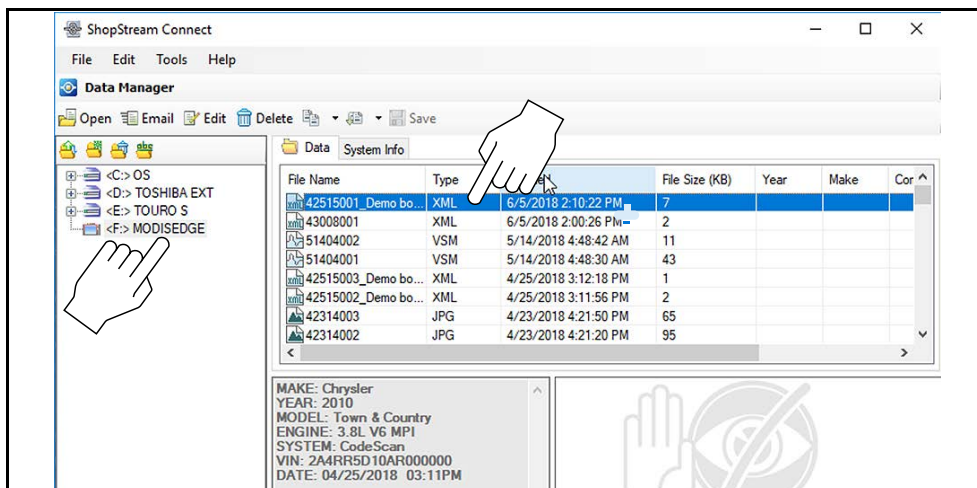

Figure 15-5

2. Select **Print** or **Print Preview** from the Code Scan Viewer menu to print or preview the Vehicle System Report (Figure 15-6).

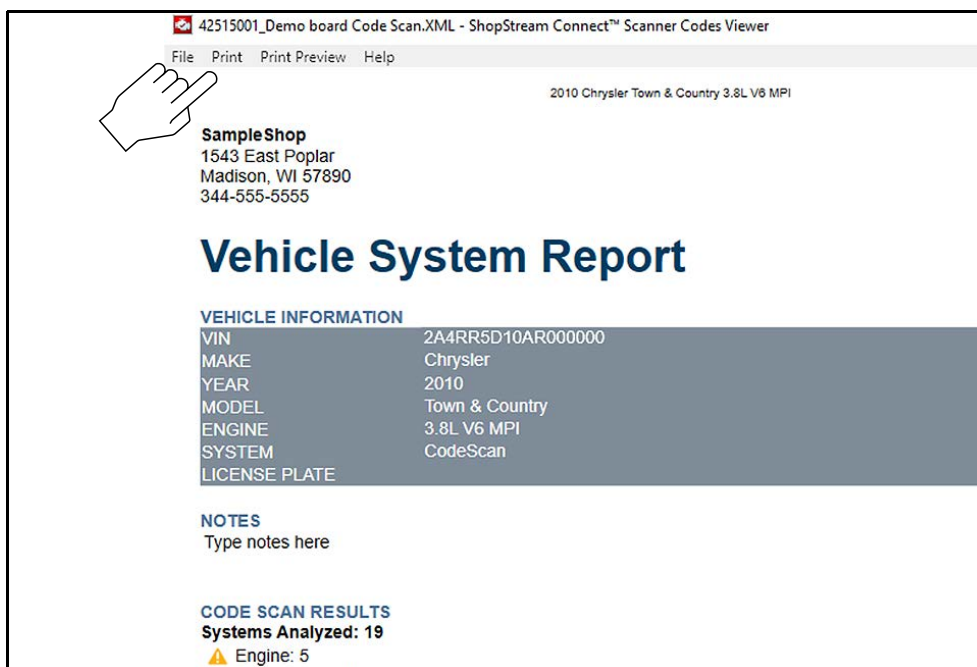

Figure 15-6

Selecting **Print** opens the Windows print dialog window (Figure 15-7). Select your printer from the list, then select **Print** to print the report.

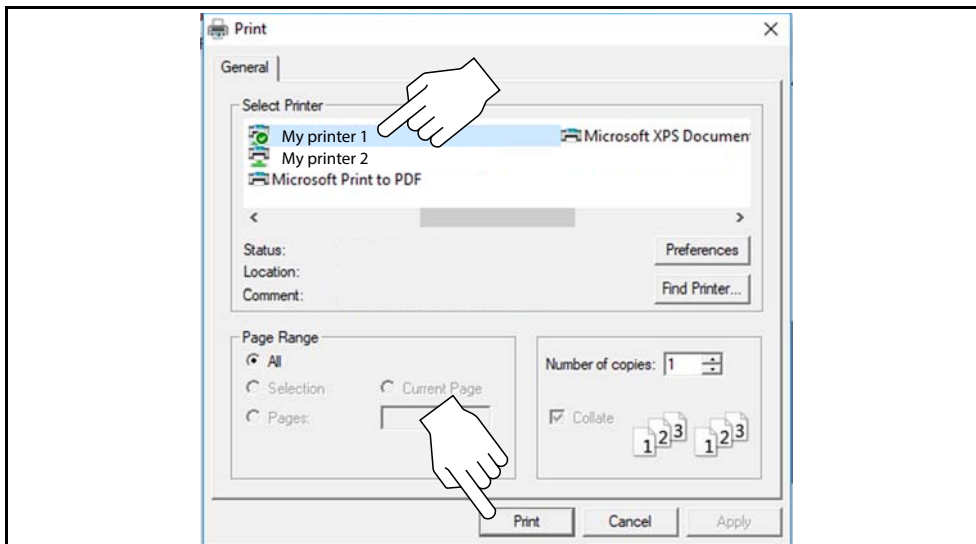

Figure 15-7

15.6 Customizing the (Code Scan) Vehicle System Report

Select fields of the Vehicle System Report can be edited, and you can also add notes to the report using ShopStream Connect.

To edit the Shop Information (header) of the Vehicle System Report:

1. From ShopStream Connect, select **Tools > Options > Edit Shop Info** (Figure 15-8).

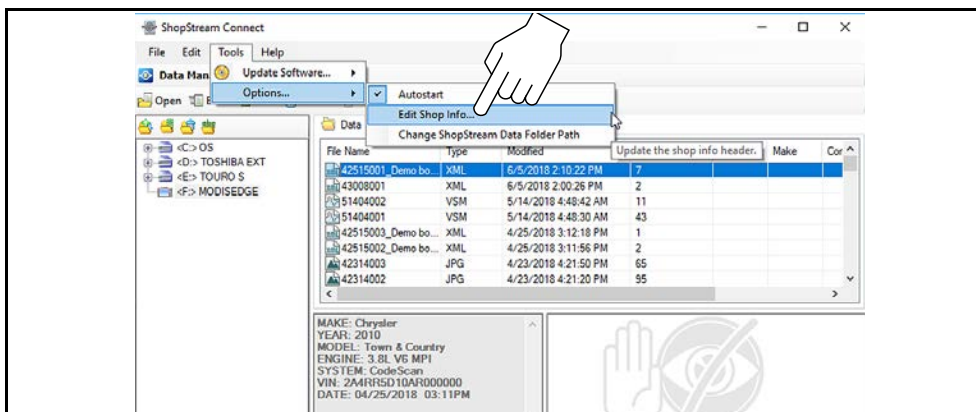

Figure 15-8

2. The **Shop Info** dialog box opens (Figure 15-9) allowing you to enter the name address, and phone number for your shop. This information is included as a header on the report.

Shop Name: SampleShop

Address 1: 1543 East Poplar

Address 2:

City: Madison

State/Province, County: WI

Zipcode: 57890

Phone 1: 344-555-5555

Phone 2:

Messages

Line 1:

Line 2:

Line 3:

Use Shop Info in Printout Header

Use timestamp in Vehicle System Report

Save

Cancel

Print Header Preview

```
6/6/2018 2:57 PM
SampleShop
1543 East Poplar
Madison WI 57890
344-555-5555
```

Figure 15-9

A preview panel at the bottom of the box shows how the information will appear on a print out (Figure 15-9).

3. Check the **“Use Shop Info in Printout Header”** box to show the Shop Info in the printout (Figure 15-9).
4. Check the **“Use timestamp in Vehicle System Report”** box to show the time the vehicle was scanned in the printout (Figure 15-9).
5. When you are finished editing, select **Save** (Figure 15-9) to save the information and close the dialog box.

To edit the VIN and License Plate fields, and/or add notes to the Vehicle System Report:

1. From ShopStream Connect, open the code scan .XML file to be edited (Figure 15-10).
2. Click in the editable fields as shown in (Figure 15-10) to change the values or add notes.
3. Check the **“Add the notes to the printed copy”** box to show the notes in the printout (Figure 15-10).

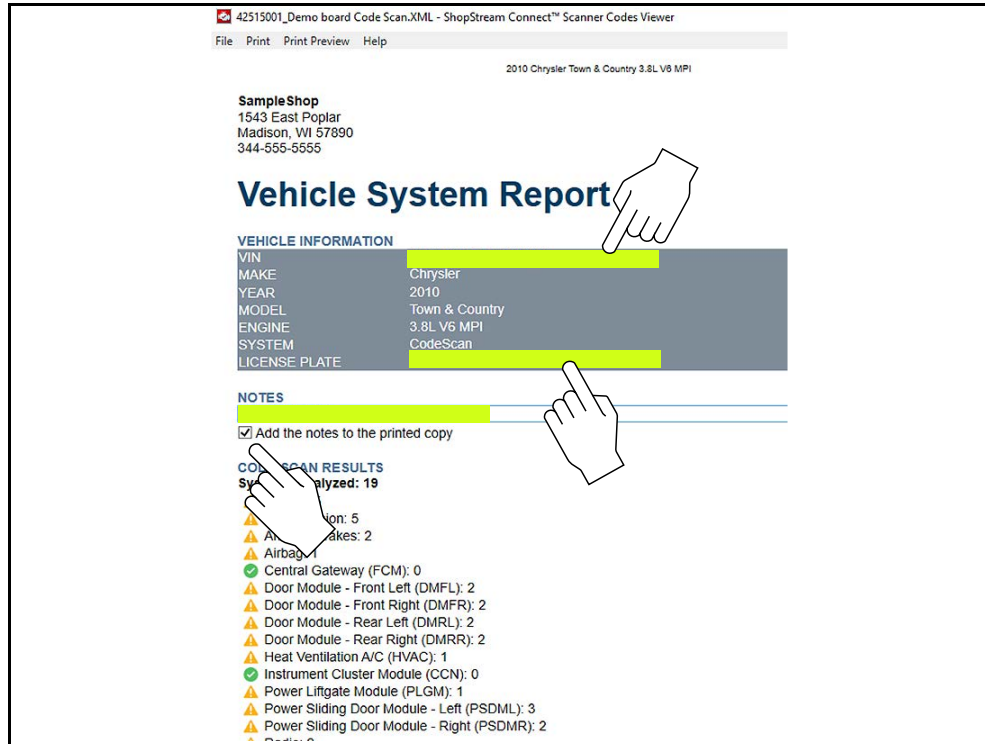

Figure 15-10

15.7 Software Upgrades and Updates

Upgrade/Update Descriptions:

- **Software Upgrade** - a software upgrade is a new software version (contact your sales representative for purchase information).
- **Software Update** - a software update is a service release for installed software. These are available free of charge, and are provided as necessary to update installed software. When your diagnostic tool is connected to a PC using SSC, the SSC software will automatically check for updates, and if an update is available, it will provide installation instructions. Follow the screen prompts to accept, download and install the software.



NOTE:

To receive updates or upgrades, SSC software must be installed on your PC and have connection to the Internet.



Example - Updating diagnostic tool software:

1. Select **Tools > Update Software >** (diagnostic tool type - e.g. ETHOS Edge, MODIS Edge, SOLUS Edge, etc.) from the Menu bar (Figure 15-11).
The software checks the Snap-on web server for available updates.

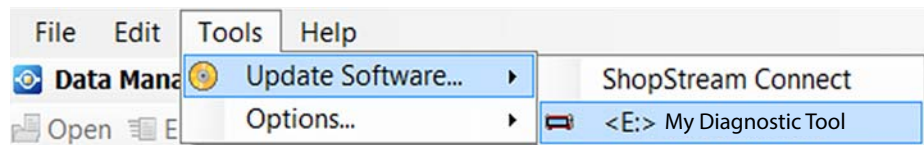

Figure 15-11

2. If service release updates are available, select **Next** to continue, then select **Download** and follow the on-screen instructions to complete the installation (Figure 15-12).

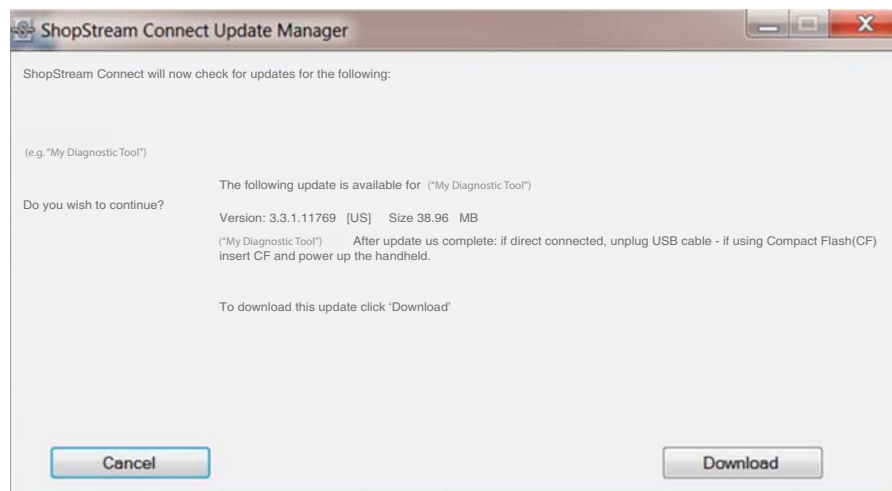

Figure 15-12

**NOTE:**

For additional information on ShopStream Connect software updates and upgrades, download the ShopStream Connect User Manual from our website:

<https://www.snapon.com/diagnostics/uk/User-Manuals.htm>

15.7.1 End User License Agreement

Before software installation at initial purchase, and before all subsequent software updates/upgrades installations End User License Agreement (EULA) acceptance is required.

IMPORTANT:

Use of Software is governed by the terms and conditions of the End User License Agreement. The diagnostic tool should not be initially operated until the End User License Agreement is read. Use of the device acknowledges your acceptance of the End User License Agreement. The Snap-on Incorporated Software End User License Agreement is available at:

<https://eula.snapon.com/diagnostics>

To Accept: at the screen prompt (Figure 15-13) click the checkbox on the left side of the window, and then select **Agree and Continue**. The software will be installed automatically.

Figure 15-13 below represents a typical EULA acceptance agreement screen.

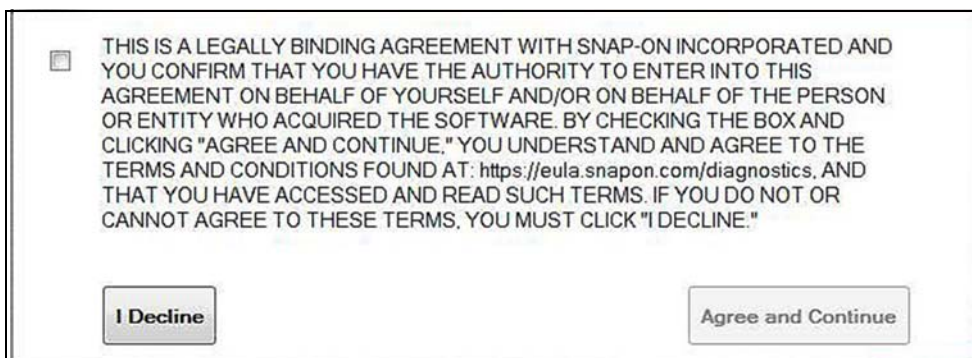

Figure 15-13 Typical EULA acceptance screen

To Decline: at the screen prompt (Figure 15-13) select **I Decline**. A confirmation message is displayed providing options to Go Back or Exit the software installation (Figure 15-14).

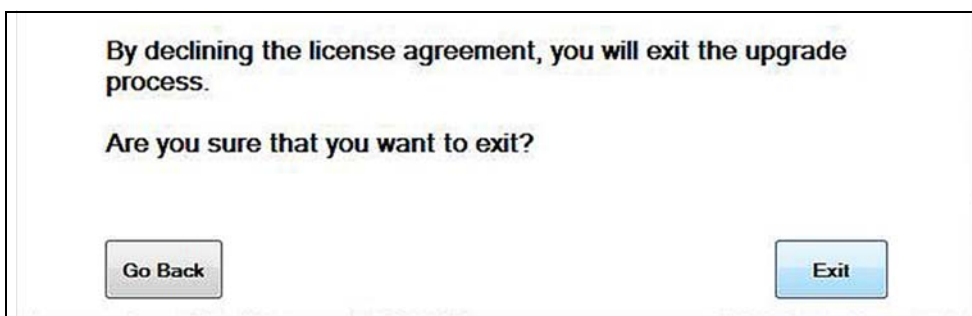

Figure 15-14 Typical EULA acceptance screen